

**PROGRAMMATIC  
HEALTH AND SAFETY PLAN**

**PG&E TOPOCK FINAL GROUNDWATER  
REMEDY PHASE 1/ PHASE 2  
CONSTRUCTION PROJECT**

**NEEDLES, CALIFORNIA**

**prepared for:**

**Pacific Gas and Electric Company**

**prepared by:**



**Programmatic Health and Safety Plan**

*Topock Final Groundwater Remedy Phase 1/ Phase 2 Construction Project*

---

# Plan Approval

See attached electronic signature approval  
\_\_\_\_\_  
Lauren Baeta  
PG&E Environmental Remediation H&S Manager

03/10/2025  
\_\_\_\_\_  
Date

*John Glass*  
\_\_\_\_\_  
John Glass  
PG&E Project Manager

03/12/2025  
\_\_\_\_\_  
Date

*David Diaz*  
\_\_\_\_\_  
David Diaz  
PG&E Site Operations Manager

03/13/2025  
\_\_\_\_\_  
Date

*Daniel Talbot*  
\_\_\_\_\_  
Daniel Talbot  
Project Construction Manager

3/12/2025  
\_\_\_\_\_  
Date

*Janet Newman*  
\_\_\_\_\_  
Janet Newman  
PMO Site Operations Manager

3/12/2025  
\_\_\_\_\_  
Date

  
\_\_\_\_\_  
Matt Michaelian, CIH, CSP  
Construction H&S Manager

3/6/2025  
\_\_\_\_\_  
Date

# Plan Approval (Amended)

\_\_\_\_\_ Date

\_\_\_\_\_ Date

\_\_\_\_\_ Date

## TABLE OF CONTENTS

<b>LIST OF TABLES .....</b>	<b>VII</b>
<b>LIST OF FIGURES .....</b>	<b>VII</b>
<b>LIST OF APPENDICES .....</b>	<b>VII</b>
<b>LIST OF ABBREVIATIONS AND ACRONYMS.....</b>	<b>IX</b>
<b>1.0 INTRODUCTION.....</b>	<b>1</b>
1.1 PROGRAMMATIC HEALTH AND SAFETY PLAN SCOPE .....	1
1.2 SITE SPECIFIC PROJECT HEALTH AND SAFETY PLANS .....	2
1.3 CONTRACTOR REQUIREMENTS .....	3
1.3.1 <i>ISNetWorld (ISN)</i> .....	3
1.3.2 <i>Gold Shovel</i> .....	4
1.4 MULTI-EMPLOYER EACH SITE WORKSITE .....	4
1.5 STOP WORK AUTHORITY .....	4
1.6 PROMOTING SAFETY CULTURE .....	4
<b>2.0 PROJECT DESCRIPTION AND OBJECTIVES.....</b>	<b>6</b>
2.1 OVERVIEW, SITE HISTORY, LOCATION AND CURRENT CONDITIONS .....	6
2.2 SITE CHARACTERIZATION DATA .....	6
2.3 PROJECT OBJECTIVES AND SCOPE OF WORK.....	7
2.4 PrHSP OBJECTIVE .....	7
2.5 IMPLEMENTATION AND MODIFICATION OF THE PRHSP .....	8
<b>3.0 PROJECT ORGANIZATION AND COORDINATION .....</b>	<b>9</b>
3.1 PG&E PROJECT STAFF.....	9
3.1.1 <i>PG&amp;E ER H&amp;S Manager</i> .....	9
3.1.2 <i>PG&amp;E Topock Project Manager</i> .....	9
3.1.3 <i>PG&amp;E Site Operations Manager</i> .....	10
3.2 PMO PROJECT STAFF.....	10
3.2.1 <i>PMO Site Operations Manager</i> .....	10
3.2.2 <i>PMO H&amp;S Coordinator</i> .....	10
3.3 TOPOCK CONSTRUCTION MANAGEMENT STAFF .....	11
3.3.1 <i>Construction Manager Principal-in-Charge</i> .....	11
3.3.2 <i>Project Construction Manager</i> .....	11
3.3.3 <i>Construction Site H&amp;S Manager</i> .....	11
3.3.4 <i>Project Site Safety Officer</i> .....	12
3.4 CONTRACTOR H&S ORGANIZATION .....	13
3.4.1 <i>Contractor Project Manager</i> .....	14
3.4.2 <i>Contractor Project H&amp;S Manager</i> .....	14
3.4.3 <i>Contractor Site Safety Officer (SSO)</i> .....	14
3.4.4 <i>Contractor Site Supervisors</i> .....	15
3.5 SUBCONTRACTORS .....	16
3.6 SITE MONITORS AND VISITORS .....	16
<b>4.0 COMMUNICATION, INSPECTION AND REPORTING REQUIREMENTS .....</b>	<b>17</b>
4.1 MEETINGS .....	17
4.1.1 <i>Daily Managers' Coordination Meetings</i> .....	17
4.1.2 <i>Daily Construction Safety Tailgate Meeting</i> .....	17
4.1.3 <i>Daily Morning H&amp;S Principals Meeting</i> .....	17
4.2 ON-SITE COMMUNICATION.....	17
4.3 INSPECTION AND H&S AUDITING.....	18
4.3.1 <i>Inspection</i> .....	18



# Programmatic Health and Safety Plan

## Topock Final Groundwater Remedy Phase 1/ Phase 2 Construction Project

---

4.3.2	Periodic Scheduled Field Audit .....	20
4.3.3	Records Audit.....	20
4.3.4	Contractor/ Subcontractor Internal Audit.....	20
4.4	REPORTING .....	20
4.4.1	Incident and Near Miss/Hit Process Requirements.....	22
4.4.2	Observations .....	24
4.4.3	H&S Metrics.....	25
4.5	MANAGING H&S PROGRAM .....	25
<b>5.0</b>	<b>GENERAL RULES AND CONDITIONS.....</b>	<b>26</b>
5.1	GENERAL SITE ACCESS.....	26
5.2	TOPOCK COMPRESSOR STATION ACCESS .....	26
5.3	CODE OF SAFE PRACTICES.....	27
5.4	OTHER SAFE WORK PRACTICES .....	28
5.4.1	Buddy System .....	28
5.4.2	Illumination .....	28
5.4.3	Spill Containment .....	28
5.4.3.1	Fuel Handling.....	28
5.4.3.2	Well Installation.....	29
5.4.3.3	Hazardous Waste .....	29
<b>6.0</b>	<b>TASK HAZARDS ANALYSIS AND REQUIRED CONTROL MEASURES .....</b>	<b>30</b>
6.1	HAZARD ANALYSIS RISK RANKING AND JSA .....	32
6.2	PHYSICAL HAZARDS .....	34
6.2.1	Fire – Structural, Equipment, Fueling and Materials Storage .....	34
6.2.2	High Voltage and Overhead Utility Lines .....	35
6.2.3	Excavation and Trenching.....	35
6.2.3.1	Outside TCS .....	35
6.2.3.2	Within TCS.....	37
6.2.4	Struck By / Falling Objects .....	37
6.2.5	Moving Machinery Parts and Equipment Guarding.....	38
6.2.6	Control of Hazardous Energy including Lock-out Tag-out (LOTO).....	38
6.2.7	Slips, Trips and Falls .....	38
6.2.8	Ergonomics.....	39
6.2.9	Work Processes Requiring Permits.....	39
6.2.9.1	Hot Work - Welding, Torch Cutting, Brazing, Grinding.....	39
6.2.9.2	Confined Space Entry .....	40
6.2.10	Work in and Around Vehicular Traffic and Control .....	41
6.3	ENVIRONMENTAL HAZARDS .....	41
6.3.1	Heat Illness.....	41
6.3.2	Cold Stress .....	45
6.3.3	Noise .....	46
6.4	SAFE USE OF CONSTRUCTION TOOLS AND EQUIPMENT.....	46
6.4.1	Tool Use .....	46
6.4.2	Ladders.....	47
6.4.3	Scaffolds.....	47
6.4.4	Mechanical and Heavy Equipment.....	47
6.5	SPECIAL HAZARDS .....	48
6.5.1	Work in or Near Steep Topography.....	48
6.5.2	Work in remote locations.....	49
6.5.3	Flash Floods.....	49
6.5.4	Work near or overwater.....	49
6.5.5	Protection from wildfire smoke .....	50
6.6	BIOLOGICAL HAZARDS.....	50
<b>7.0</b>	<b>CHEMICAL HAZARDS .....</b>	<b>51</b>

# Programmatic Health and Safety Plan

## Topock Final Groundwater Remedy Phase 1/ Phase 2 Construction Project

---

7.1	ESTIMATE OF THE LEVEL OF HEALTH RISKS.....	51
7.2	ACTION LEVELS.....	51
7.3	AREAS OF CONCERN AND CHEMICALS OF CONCERN.....	52
7.4	EXPOSURE LEVELS.....	53
7.5	AIR MONITORING.....	54
7.5.1	<i>Action Levels</i> .....	54
7.5.2	<i>Equipment</i> .....	57
7.6	COMBUSTIBLE/EXPLOSIVE GASES AND OXYGEN DEFICIENT/ENRICHED ATMOSPHERES.....	57
7.7	DOCUMENTATION.....	57
<b>8.0</b>	<b>VEHICLE SAFETY.....</b>	<b>59</b>
8.1.1	<i>Authorized Drivers</i> .....	59
8.1.2	<i>General Operating Policy and Procedure</i> .....	59
8.1.3	<i>Field Site Vehicle Safety</i> .....	60
8.1.4	<i>Off-Road Vehicle Safety</i> .....	61
<b>9.0</b>	<b>PERSONAL PROTECTIVE EQUIPMENT.....</b>	<b>62</b>
9.1	REQUIREMENTS.....	63
9.1.1	<i>Eye Protection/Safety Glasses</i> .....	63
9.1.2	<i>Hand Protection/Gloves</i> .....	63
9.1.3	<i>Head Protection/Hard Hats</i> .....	63
9.1.4	<i>Foot Protection/Steel Toed Shoes</i> .....	63
9.1.5	<i>Clothing</i> .....	63
9.1.6	<i>Fall Protection</i> .....	63
9.1.7	<i>Respirator and Cartridges</i> .....	63
9.2	LEVEL D PPE.....	64
9.3	LEVEL C PPE.....	65
9.4	LEVEL B PPE.....	65
9.5	LEVEL A PPE.....	65
9.6	RESPIRATORY PROTECTION UPGRADE GUIDELINES.....	65
9.7	ADDITIONAL SAFETY EQUIPMENT.....	67
9.7.1	<i>First Aid Kits</i> .....	67
9.7.2	<i>Automated External Defibrillator (AED)</i> .....	67
9.7.3	<i>Portable Eyewash Stations and Showers</i> .....	68
9.7.4	<i>Fire Extinguishers</i> .....	68
<b>10.0</b>	<b>DESIGNATED WORK AREAS.....</b>	<b>69</b>
10.1	WORK OUTSIDE OF AOCs AND NO GROUNDWATER CONTACT.....	69
10.1.1	<i>Work Zone</i> .....	69
10.1.2	<i>Observation Zone</i> .....	69
10.2	WORK WITHIN AOCs OR WORK WHERE GROUNDWATER CONTACT MAY OCCUR.....	69
10.2.1	<i>Support Zone</i> .....	69
10.2.2	<i>Contamination Reduction Zone</i> .....	70
10.2.3	<i>Exclusion Zone</i> .....	70
10.3	CONTROLLED ACCESS ZONE.....	70
<b>11.0</b>	<b>DECONTAMINATION PROCEDURES.....</b>	<b>71</b>
11.1	PERSONNEL.....	71
11.2	EQUIPMENT.....	71
<b>12.0</b>	<b>SANITATION FACILITIES AND DRINKING WATER.....</b>	<b>72</b>
<b>13.0</b>	<b>SITE SECURITY AND CONTROL.....</b>	<b>73</b>
13.1	SITE SECURITY.....	73
13.2	WORK HOURS.....	73

# Programmatic Health and Safety Plan

## Topock Final Groundwater Remedy Phase 1/ Phase 2 Construction Project

---

13.3	AFTER HOURS/WEEKEND OPERATIONS.....	74
<b>14.0</b>	<b>TRAINING AND MEDICAL SURVEILLANCE REQUIREMENTS .....</b>	<b>75</b>
14.1	INITIAL TRAINING .....	75
14.1.1	<i>HAZWOPER Training .....</i>	<i>75</i>
14.1.2	<i>Hazard Communication Program.....</i>	<i>75</i>
14.1.3	<i>Site-Specific H&amp;S Pre-Job Training.....</i>	<i>76</i>
14.2	DAILY SITE SAFETY TRAINING.....	77
14.3	MEDICAL SURVEILLANCE FOR HAZWOPER .....	77
14.4	MEDICAL SURVEILLANCE FOR HEAT STRESS .....	77
14.5	MEDICAL SURVEILLANCE FOR RESPIRATOR USAGE.....	77
<b>15.0</b>	<b>EMERGENCY RESPONSE AND EVACUATION PLAN .....</b>	<b>78</b>
15.1	EMERGENCY TELEPHONE NUMBERS .....	78
15.2	NEAREST HOSPITAL AND CLINIC INFORMATION .....	79
15.3	SITE EMERGENCIES AND EVACUATION ROUTE.....	82
15.3.1	<i>Personnel roles, lines of authority and communication .....</i>	<i>82</i>
15.3.2	<i>Evacuation and Muster Point Locations.....</i>	<i>82</i>
15.4	PRE-EMERGENCY PLANNING.....	84
15.5	SITE RESOURCES / EMERGENCY EQUIPMENT .....	85
15.6	EMERGENCY HAND SIGNALS .....	85
15.7	EMERGENCY SITE SECURITY AND CONTROL.....	85
15.8	CONTINGENCY PROCEDURES .....	85
15.8.1	<i>Fire .....</i>	<i>85</i>
15.8.2	<i>Material Spills.....</i>	<i>86</i>
15.8.3	<i>Earthquake.....</i>	<i>86</i>
15.8.4	<i>Severe Weather .....</i>	<i>86</i>
15.8.5	<i>Vehicle Accidents.....</i>	<i>88</i>
15.8.6	<i>Workplace Violence .....</i>	<i>88</i>
15.8.7	<i>Biological Bites and Stings.....</i>	<i>89</i>
15.9	EMERGENCY DECONTAMINATION PROCEDURES .....	89
15.10	PERSONAL INJURY .....	90
15.10.1	<i>Heat Illness .....</i>	<i>90</i>
15.10.2	<i>Electrocution .....</i>	<i>90</i>
15.10.3	<i>Emergency Medical Treatment and First Aid.....</i>	<i>90</i>

## Programmatic Health and Safety Plan

### Topock Final Groundwater Remedy Phase 1/ Phase 2 Construction Project

---

#### LIST OF TABLES

<u>Table No.</u>	<u>Title</u>
4-1	<i>Minimum Inspection Requirements</i>
4-2	<i>Minimum Required Reporting Summary</i>
4-3	<i>Event Reporting Guidance</i>
4-4	<i>Observation Reporting Guidance</i>
6-1	<i>Key Safety and Health Hazards for Remedy General Scope of Work</i>
6-2	<i>Hazard Risk Matrix</i>
6-3	<i>NIOSH Work Rest Schedule for Workers Wearing Normal Clothing</i>
6-4	<i>Power Line Clearance</i>
7-1	<i>Project Chemicals of Concern</i>
7-2	<i>Calculated Minimum Airborne Dust Limits to Reach OEL or AL</i>
7-3	<i>General Site Action Level Criteria</i>
9-1	<i>Quick Selection Guide for Minimum Required PPE</i>
9-2	<i>Level D Required Personal Protective Equipment</i>
9-3	<i>Level C Required Personal Protective Equipment</i>
9-4	<i>Respirator Protection Factors</i>
9-5	<i>Additional Safety Supplies and Equipment</i>
15-1	<i>Emergency Contact List</i>
15-2	<i>Emergency Signals</i>

#### LIST OF FIGURES

<u>Figure No.</u>	<u>Title</u>
1	Site Location Map
2	Site Map including Areas of Concern and Construction Footprint
3	PG&E Construction Project Organizational Chart
4	Site Evacuation Route
5	Site Evacuation Route – Arizona Well Locations

#### LIST OF APPENDICES

<u>Appendix</u>	<u>Title</u>
A	PrHSP Training Roster
B	PG&E PHSP Checklist
C	PG&E Bridging Documents
D	General Audit Checklist
E	PG&E ER Contractor Reporting Guidance
F	PG&E ER Contractor Event Reporting – Project Quick Reference
G	PG&E ER Contractor Observation Guidelines
H	Example H&S Metrics Form
I	PG&E Code of Safe Practices: Sections 1 General Rules, 2 – First Aid, 3 – Motor Vehicle Operation
J	Topock Remedy Work Task List

## **Programmatic Health and Safety Plan**

### *Topock Final Groundwater Remedy Phase 1/ Phase 2 Construction Project*

---

K	PG&E Utility Work Procedure 4412P-05 – Excavation Procedures for Damage Prevention
L	PG&E Utility Standard ENV-9201S – Utility Identification and Strike Avoidance Standard
M	TCS Excavation Guidance
N	PG&E Slope Safety Standard
O	Topcock Remedy Biological Hazards
P	Contaminants Of Concern Primary Health Hazards and OELs
Q	PG&E ATV/UTV Guidance Documents
R	NIOSH Chemical Hazard Sheets
S	Example of CAL/OSHA Training Requirements
T	U.S. DHHS, CDC, NIOSH Recommendations for an Occupational Standard for Workers Exposed to Heat and Hot Environments
U	TCS Assembly Point Map
V	PG&E Contractor Handbook
W	PGE Journey Management Plan & Trip Risk Assessment Guidance

## **LIST OF ABBREVIATIONS AND ACRONYMS**

ACGIH	American Conference of Governmental Industrial Hygienists
ACM	asbestos containing material
ADOSH	Arizona Department of Safety and Health
AED	automated external defibrillator
AEG	Advanced Environmental Group, Inc.
AHA	activity hazard analysis
AL	action level
ANSI	American National Standard Institute
AOC	area of concern
APR	air-purifying respirator
ASTM	American Society for Testing and Materials
ATV	all-terrain vehicle
BBP	blood borne pathogen
BBS	behavior-based safety
BLM	Bureau of Land Management (U.S.)
BOR	Bureau of Reclamation (U.S.)
Cal/EPA	California Environmental Protection Agency
Cal/OSHA	California Occupational Safety and Health Administration
CAS	Chemical Abstract Service Number
CAZ	controlled access zone
CCR	California Code of Regulations
CDC	Center for Disease Control
CERCLA	Comprehensive Environmental Response, Compensation, and Liability Act
CFR	Code of Federal Regulations
CGI	combustible gas indicator
CHEMTREC	Chemical Transportation Emergency Center
CHQ	construction headquarters
CHSM	construction health and safety manager
CIH	Certified Industrial Hygienist
CMPIC	construction manager principal in charge
CO	carbon monoxide
COC	chemicals of concern
CPP	COVID Protection Program
CPR	cardiopulmonary resuscitation
CRAWP	Construction Remedial Action Work Plan
CSL	commercial screening level
dBA	decibels, A-scale
DHHS	Department of Health and Human Services
DOI	[US] Department of the Interior
DOSH	Department of Safety and Health
DOT	Department of Transportation
DTSC	Department of Toxic Substances Control
EL	exposure limit

## Programmatic Health and Safety Plan

Topock Final Groundwater Remedy Phase 1/ Phase 2 Construction Project

---

ER	[PG&E] Environmental Remediation Department
ERTC	Environmental Release to Construction
FMIT	Fort Mojave Indian Tribe
FR	Flame Resistant
GFCI	ground fault circuit interrupters
H&S	health and safety
HAZWOPER	Hazardous Waste Operations and Emergency Response
HEPA	high efficiency particulate absolute
HNWR	Havasu National Wildlife Refuge
HRC	hazard risk category
HSC	health and safety coordinator
HSM	health and safety manager
IDLH	immediately dangerous to life and health
IIPP	illness injury prevention program
ISN	ISNetworld
JHA	job hazard analysis
JSA	job safety analysis
LEL	lower explosive limit
LOTO	lock out tag out
MMRP	Mitigation Monitoring and Reporting Program
MPH	miles per hour
MSHA	Mine Safety and Health Administration
MUL	maximum use limit
NFPA	National Fire Protection Association
NIOSH	National Institute for Occupational Safety and Health
NSC	National Safety Council
OBZ	operator's breathing zone
OEEHA	Office of Environmental Health Hazard Assessment
OEL	occupational exposure limit
OSHA	U.S. Occupational Safety and Health Administration
PAH	polycyclic aromatic hydrocarbons
PAPR	powered air purifying respirator
PCB	polychlorinated biphenyl
PCM	project construction manager
PDR	personal DataRAM™
PEL	permissible exposure limit
PF	protection factor
PFD	personal floatation device
PG&E	Pacific Gas and Electric
PHSP	project health and safety plan
PID	photo ionization detector
PIVOX	PIVOX Corporation
PM	project manager
PMO	PG&E Chromium Remediation Program Management Office
PNOR	particles not otherwise regulated
PPE	personal protective equipment

## **Programmatic Health and Safety Plan**

*Topock Final Groundwater Remedy Phase 1/ Phase 2 Construction Project*

---

PrHSP	Programmatic Health and Safety Plan
PSSO	project site safety officer
PVC	polyvinyl chloride
RCA	root cause analysis
RCRA	Resource Conservation and Recovery Act
REL	recommended exposure level
RP	responsible person
SDS	safety data sheet
SLM	sound level meter
SMS	spun-bonded, melt bound, spun-bonded
SOM	Site Operations Manager
SOP	standard operating procedure
SSO	site safety officer
STEL	short term exposure limit
TCS	Topock Compressor Station
TLV	threshold limit value
TPH	total petroleum hydrocarbon
TSI	truck safety inspection
TWA	time-weighted average
USEPA	U.S. Environmental Protection Agency
USFWS	U.S. Fish and Wildlife Service
UTV	utility task or terrain vehicle
VOC	volatile organic compounds
WEAT	Worker Environmental Awareness Training



## **1.0 INTRODUCTION**

This Programmatic Health and Safety Plan (PrHSP) has been prepared in accordance with all applicable Federal, State and Local required standards and Pacific Gas and Electric (PG&E)'s Environmental Remediation Department (ER) Contractor Safety Program Contract Requirements. This plan addresses anticipated construction activities to be conducted during the PG&E Topock Final Groundwater Remedy Construction project herein referred to as the "Project", spanning an approximately 185-acre area outside of Needles, CA, herein referred to as "Site" (see Figure 1). All applicable written plans will be available on-site within the construction headquarters office (CHQ) and will be made available electronically.

The potential physical and chemical hazards associated with the construction activities are described and addressed in this PrHSP. The following sections present standard health and safety procedures, potential Site-specific hazards, and precautionary measures applicable to the Site.

In simple terms, this PrHSP is intended to prepare PG&E representatives, contractors, subcontractors, regulatory officials, observers, and visitors for anticipated potential hazards and enable them to respond to changing conditions and to make professional judgments regarding the interpretation of monitoring data and related control measures. The procedures in this PrHSP have been developed based upon current knowledge regarding the specific chemical and physical hazards which are known or anticipated to be encountered in the operations to be conducted at the work site. Although this PrHSP covers all anticipated work activities, there may be unexpected activities not covered as the project progresses. This PrHSP will be revised as necessary, with approval from PG&E and PG&E Remediation Program Management Office (PMO). The PMO provides program and project management services on behalf of PG&E and has the overall responsibility for management and administration of the construction and environmental remediation services provided for the Project.

It is PG&E's policy that all activities covered by this PrHSP be conducted in accordance with their Contractor Safety Standard (PG&E Utility Standard SAFE-3001S), relevant codes of safe practices, and task specific health and safety guidelines. In addition, contractors and subcontractors will comply with this written plan and applicable federal, state, and local safety and health regulations, including applicable General Industry and Construction Standards. All personnel covered by this PrHSP who cannot, or will not, comply with these requirements will be excluded from project activities.

### **1.1 PROGRAMMATIC HEALTH AND SAFETY PLAN SCOPE**

This PrHSP will direct the overall health and safety program during the Project. The information and procedures contained herein provide project information and serve as the basis for the development of site-specific project health and safety plans (PHSPs) by PG&E's Remedy contractors. The Project involves a broad array of construction tasks, from well drilling to the installation of high-voltage electrical equipment, and tunneling

## **Programmatic Health and Safety Plan**

### *Topock Final Groundwater Remedy Phase 1/ Phase 2 Construction Project*

---

under active roadways, each with their own specific hazards and Health and Safety (H&S) requirements. The objective of the PrHSP is to provide clear and concise project health and safety rules, reporting requirements, site-specific hazard data, and associated information; so, all parties conducting or supporting Phase 1/2 construction work can prepare and implement consistent and effective H&S for their specific operations.

Contractors and consultants will prepare their own specific PHSPs that cover their work, including detailed hazard analysis, under the umbrella of this PrHSP (see section 1.2). This PrHSP will also be used to develop safety training modules to train personnel involved with the project including workers, compliance monitors (Jacobs and subcontractors), other monitors (tribal, biological, archeological, and cultural) and visitors. All personnel will sign a training roster documenting their participation, acknowledgement of understanding, agreement, and acceptance, of its contents prior to the start of field activities or operations, see Appendix A for an example. This training will be in addition to other site orientation training (e.g., Worker Environmental Awareness Training [WEAT]) required to work at the Site, which is required initially, with annual refresher.

## **1.2 SITE SPECIFIC PROJECT HEALTH AND SAFETY PLANS**

PG&E has established specific guidance for determining project-specific risk and ensuring that minimum oversight expectations are met in the field. The PG&E Contractor Safety Program applies to all contractors and subcontractors, of any tier, performing medium- and/or high-risk work.

Based on the scope of work, duration of work and assessment of health and safety risks, contractors and subcontractors providing medium or high-risk work will prepare a Project Health and Safety Plan (PHSP) for review by PMO and approval by PG&E, or their designee, prior to mobilizing to the Site. Upon approval by the Project Construction Manager (PCM) and PMO, subcontractors performing limited or specialized work with no subcontractors of their own may perform work under their client contractor's approved PHSP. However, all subcontractors must prepare Job Safety Analysis (JSA) specific to work performed on-site that will be reviewed and approved by PG&E ERHSM, PG&E PM, PMO and/or their designee prior to starting work.

Contractors required to prepare and submit a PHSP, will ensure that all applicable topics outlined in PG&E's PHSP Project Review Checklist, as described in Appendix B, are addressed. These include but are not limited to detailed health and safety procedures, hazard analysis, communications, and requirements specific to their work. All PHSPs must meet the requirements of applicable California-specific regulations, such as the California Occupational Safety and Health Administration (Cal/OSHA), Hazardous Waste Operations and Emergency Response (HAZWOPER) regulations found in Title 8 of the California Code of Regulations (CCR), Section 5192 (CCR T8 Section 5192).

PHSPs that include work within the Topock Compressor Station (TCS) are to provide detailed TCS-specific H&S rules and procedures. See Section 5.2 for information on TCS unescorted access.

## **Programmatic Health and Safety Plan**

### *Topock Final Groundwater Remedy Phase 1/ Phase 2 Construction Project*

---

Contractors are required to provide suitably trained and experienced workers, equipped with their own personal protective equipment (PPE). All training will be submitted to PG&E and Construction Health and Safety Manager (CHSM) or his designee prior to the commencement of work. Moreover, contractors and sub-contractors for the subject project are required to have established health and safety procedures of their own that cover the work activities they are responsible for and that are at least as stringent as this PrHSP. In the event of a discrepancy between this PrHSP and a contractor's health and safety procedures, this PrHSP will take precedence.

All PHSPs and JSAs will be submitted for review at least three weeks prior to the start of work. Any subsequent or supplemental JSA will be submitted for review at least 14 calendar days prior to start of work. Contractors must also complete PGE's "Bridging document" which will be submitted with the PHSP, Reference documents in Appendix C. PHSPs will be reviewed as per PG&E's PHSP Project Review Checklist. PHSPs for contractors directly contracted to PMO will be reviewed by the PMO. PG&E ER will review all top-tier (contracted to PMO or directly to PG&E) PHSPs. PG&E ER and/or PMO may review lower-tier subcontractor PHSPs at their discretion. No work may be performed without PHSP and JSA approval by PG&E ER compliance.

Such review or failure to object to the contractor's PHSP must not in any manner be a representation that the PHSP is sufficient for the contractor's work and all parties listed above do not, by their review, assume any liability for any deficiency or inaccuracy in the contractor's PHSP.

All contractors, subcontractors and personnel working under approved PHSPs must follow the procedures described therein. Personnel will also be required to review and sign documenting and acknowledging that they will follow the relevant PHSP when visiting an active work zone governed by a PHSP. A copy of contractor's PHSP must be available on-site, along with current documentation/signatures listing personnel who have agreed to follow the PHSP.

## **1.3 CONTRACTOR REQUIREMENTS**

### **1.3.1 ISNetWorld (ISN)**



PG&E requires all contractors and subcontractors performing medium or high-risk work to be pre-qualified (receive a PG&E-specific ISN certification with an A or B grade) through ISN and comply with ISN requirements. Therefore, contractors and subcontractors will ensure that all new and existing personnel, in performance of work on this project, are in compliance with ISN, training requirements and wearing ISN issued badges while on-site.

### 1.3.2 Gold Shovel



Gold shovel is part of PG&E's Contractor Safety Program. Contractors and subcontractors performing applicable civil, excavation and trenching work are required to provide their Gold Shovel certification(s) prior to commencement of intrusive work. Contractors must also develop and adhere to a Dig-In Prevention Policy that incorporates these elements.

## 1.4 MULTI-EMPLOYER EACH SITE WORKSITE

This jobsite is considered a multi-employer worksite as defined in Division of Occupational Safety and Health (DOSH) Policy and Procedure Manual P & P C-1C and CCR, Title 8, Sections 336.10 and 336.11. The controlling employer during construction activities is responsible for safety and health conditions at the worksite and has the authority to correct or have a non-compliant condition corrected by its subcontractors. All stakeholders, who will be involved in work activities will implement good work practices, engineering, or administrative controls, and will report observed violations or excursions to the General Contractor and controlling employer. If the creating employer fails to correct the violation, the work will stop, and the controlling employer will be notified.

H&S at a multi-employer worksite will be managed based on the specific contractual relationships at the specific work area. At a minimum, all H&S requirements provided in this PrHSP, contractor PHSPs, and project specifications will flow down to all personnel on the site, regardless of the specific contractual details. Each contractor's PHSP shall acknowledge methods to comply with this requirement.

## 1.5 STOP WORK AUTHORITY

PG&E recognizes that to achieve the safest possible work environment, all personnel working onsite must be empowered to assume responsibility for their own safety and the safety of others. All personnel will have the authority and responsibility to stop work that they feel is unsafe at any time and bring the issue to the attention of their organization, PG&E, or others without repercussion.

## 1.6 PROMOTING SAFETY CULTURE

A safety culture is built on the compilation of all our safe behaviors and attitudes. Behavior Based Safety (BBS) principles will be a flow-down requirement on this project to facilitate a safety culture. BBS is a set of principles to be used in delivering all other programs and procedures during implementation of this project. Its purpose is to influence personal attitudes by focusing on observable behaviors, reinforcing exemplary behaviors, and correcting unsafe behaviors which are typically the root causes of accidents.

Contractor leadership will implement behavior observations to identify safe/at-risk behaviors. Until an individual is fully incorporated into safety culture, mentoring arrangements may be implemented for recent hires. Participation, Ownership, Personal

**Programmatic Health and Safety Plan**

*Topock Final Groundwater Remedy Phase 1/ Phase 2 Construction Project*

---

Responsibility are key elements to BBS. See section 4.4.2 for required observation schedules.

## **2.0 PROJECT DESCRIPTION AND OBJECTIVES**

### **2.1 OVERVIEW, SITE HISTORY, LOCATION AND CURRENT CONDITIONS**

The Site is located adjacent to the Colorado River in eastern San Bernardino County, California, approximately 12 miles southeast of Needles, California, at the north end of the Chemehuevi Mountains. The surrounding project site includes land owned and/or managed by government and private entities including PG&E, the U.S. Bureau of Reclamation (BOR) (managed by the U.S. Bureau of Land Management [BLM]), the U.S. Fish and Wildlife Service (USFWS) (managing the Havasu National Wildlife Refuge [HNWR]), San Bernardino County, BNSF Railroad, Fort Mojave Indian Tribe (FMIT), and the Southern California Metropolitan Water District.

Investigative and remedial activities at and near the Topock Project are being performed under the Resource Conservation and Recovery Act (RCRA) Corrective Action process, as well as the Comprehensive Environmental Response, Compensation, and Liability Act (CERCLA), pursuant to agreements with the California Environmental Protection Agency (Cal/EPA), Department of Toxic Substance Control (DTSC), and the U.S. Department of the Interior (DOI). Under the terms of these agreements, PG&E has been conducting the RCRA facility investigation/remedial investigation. Multiple phases of the RCRA facility investigation/remedial investigation have been performed since 1996. The existing chromium contamination in groundwater is largely attributable to historical wastewater discharge from the TCS operations to Bat Cave Wash and within the East Ravine.

### **2.2 SITE CHARACTERIZATION DATA**

Soil and groundwater investigations have been performed at the Topock site, and the Site has been divided into investigation subareas based on contaminant sources or contaminant groups – subareas referred to as areas of concern (AOC)s, solid waste management units and the extent of groundwater contamination. Phase 1/2 construction activities are planned in and near a number of these soil and groundwater investigation areas. Figure 2 is a site map that illustrates soil and groundwater investigation areas, wells (existing, provisional, planned), and the approximate construction footprint.

PG&E believes, based on the extensively evaluated TCS site history (RFI Vol. 1 & Vol. 2), no known ionizing radiation-emitting substances were used or disposed of in the work areas covered by this plan.

This PrHSP addresses the contaminants previously detected in soil and groundwater. Further discussion on specific soil and groundwater contaminants are included in Section 7.0.

Asbestos-containing material (ACM) was observed during previous field activities at the Site within the approximate maximum construction footprint specifically in AOC 12 and AOC 4 reference Figure 2. Soil samples were collected at some of these locations, and concentrations of asbestos were either very low (less than 0.1 percent) or not detected. Although not anticipated, if suspect ACM is discovered during site activities, work will



immediately stop, area cordoned off, PCM, PG&E, and external agencies, as required, will be notified, and the suspect material tested by a California certified asbestos inspector. Further disturbance of the suspect material will continue only after negative test results are reported, or if necessary, PHSPs are amended to address the presence of ACM.

## **2.3 PROJECT OBJECTIVES AND SCOPE OF WORK**

Key to any activity at the project site is working safely and protecting the environment. Protecting the environment encompasses preventing release of contaminants into the air, soil, and water, as well as protecting biological and cultural resources.

The Project will be broken into discrete tasks. Multiple organizations will be contracted to implement work required to build the component tasks described below.

The general scope of work for this project includes monitoring and remediation well drilling, installation, and testing; construction of remediation well-head infrastructure, construction of underground water conveyance pipelines; construction of above-ground water storage infrastructure; construction of buildings and above-ground structures; grading and earthwork; construction of electrical infrastructure; and construction of controls/instrumentation infrastructure. All construction work will require biological, environmental, and cultural monitoring.

## **2.4 PrHSP OBJECTIVE**

The primary goal of this PrHSP is to facilitate and maintain a safe and healthy work environment during the construction activities performed onsite. The PrHSP has been developed to fulfill this goal and achieve the following objectives:

- Provide standardized, consistent health and safety procedures to be used to develop PHSPs to be followed by all while on-site.
- Instruct personnel and contractors on project-wide procedures to minimize the potential for injury or exposure to hazardous conditions.
- Train personnel and contractors on the proper action to be taken if a hazardous condition cannot be avoided by general controls.
- Provide guidelines for emergency response for known hazards and hazardous situations.
- Specify actions required to comply with applicable U.S. Department of Labor, U.S. Occupational Safety and Health Administration (OSHA), Cal/OSHA, Arizona Department of Safety and Health (ADOSH) (Arizona Well Location), state and local regulations or other requirements.

Furthermore, this PrHSP is intended as a guideline that allows the contractors, subcontractors, regulatory officials, stakeholders, observers, and visitors to respond to changing conditions and make professional judgments regarding the interpretation of monitoring data and related control measures.

Finally, this PrHSP delineates health and safety responsibilities and assigns those responsibilities to project and office personnel, See Section 3.0.

## **2.5 IMPLEMENTATION AND MODIFICATION OF THE PRHSP**

Specific health and safety program requirements will facilitate and promote health and safety communication, such as mandatory health and safety “tailgate” meetings, which will be held prior to starting work each day to discuss safety procedures, familiarize personnel with potential hazards, and answer questions. Meeting, inspection, and reporting requirements are outlined in Section 4.0. Daily sign-in sheets, inspection forms and all other health and safety documentation will be captured by contractors and the respective construction management team, electronically.

Should site-specific conditions change significantly (e.g., additional chemicals or safety hazards are discovered) or additional work activities are required that are not covered in this PrHSP, work will stop until an addendum to address site-specific changes will be initiated then an addendum will be prepared. Revisions will be reviewed and approved by PG&E and the PMO prior to implementation. PrHSP amendments will also be forwarded to agencies. After approval, no additional work activity will be performed until appropriately trained, qualified, and outfitted personnel are available.

Proposed changes to this PrHSP will be discussed with the Project construction management staff leads. All amendments will be posted and distributed through an internal project electronic repository to project contractors and subcontractors. Site personnel will be informed of changes to the PrHSP at the daily tailgate meetings and will be required to sign the PrHSP addendum to indicate that they have read and understand it.



### **3.0 PROJECT ORGANIZATION AND COORDINATION**

The following section describes general roles and responsibilities for PG&E, PMO and contractor project H&S leadership.

Valuing personal safety, working in a safe manner, understanding, and following established H&S practices and requirements is the responsibility of every person involved with the construction of the Project, whether they represent PG&E, a contractor, a project stakeholder, or a visitor. It is up to the entire project team, starting with project leadership, to establish a culture of safety during the implementation of this project.

It is also the responsibility of the project leadership to ensure that all project personnel understand they have stop work authority when confronted with potentially unsafe actions or conditions.

The Topock construction project team, including PG&E, Construction Management, PMO, Contractors, and Subcontractors, are illustrated via organizational chart in Figure 3 and described below. The roles below may change, or one person may serve more than one role as the Project construction project evolves. The Project H&S reporting structure is as follows: Contractor SSO → Project Site Safety Officer (PSSO) → CHSM → PCM → Construction Manger Principal in Charge (CMPIC) → PG&E/PMO.

#### **3.1 PG&E PROJECT STAFF**

PG&E, as the Owner of the Project, has the ultimate responsibility for the project implementation and coordination with Stakeholders, including the regulatory agencies, Tribal entities, and the public.

##### **3.1.1 PG&E ER H&S Manager**

Lauren Baeta – PG&E – (925) 655-7002

The PG&E ER Health & Safety Manager (PG&E ERHSM) is responsible for managing PG&E's health and safety program for the Environmental Remediation Department. The PG&E ER H&S Manager will not have day-to-day involvement with the Project; however, he/she will be responsible for setting Company standards for H&S operations and culture. The PG&E ER H&S Manager or his/her designee will approve this PrHSP, all PHSPs that require PG&E approval, and all submitted JSAs. The PG&E ER Health and Safety Manager may become involved in resolving issues or H&S questions that cannot be resolved within the construction project team, responding to H&S incidents, or providing high-level H&S inspections during implementation.

##### **3.1.2 PG&E Topock Project Manager**

John Glass – PG&E – (628) 219-4369

The PG&E Topock Project Manager (PG&E PM) is responsible for the overall direction of the project, relations with external stakeholders, and regulatory compliance issues. The PG&E PM is responsible for communication, including status reporting, risk management,

escalation of issues that cannot be resolved within the construction project team, and will serve as review and approval authority where the construction project potentially affects long term regulatory compliance of the Project or acceptance by external stakeholder. In general, the PG&E PM will serve as the primary point of contact between the Project and outside stakeholders of the Topock project.

The PG&E PM is responsible for staying apprised of H&S performance during implementation of the project and maintaining compliance with PG&E's H&S program requirements. The PG&E PM may perform site inspections and audits, may assist with incident investigations, and will serve as a liaison along with the PG&E ER H&S Manager.

### 3.1.3 PG&E Site Operations Manager

David Diaz – PG&E – (760) 903-3013

The PG&E Site Operations Manager (PG&E SOM) is the primary point of contact for field activities related to the construction project. The PG&E SOM holds daily meetings, coordinates site operations, and provides review for contractor submittals in coordination with the PG&E PM. The PG&E SOM also has front-line responsibility for implementing PG&E's H&S program during the full life cycle of Remedy implementation and works with the PG&E PM to manage PG&E H&S during the Project construction.

The PG&E SOM reviews all H&S documentation and performance data; leads PG&E-driven H&S inspections and audits; and is an additional liaison with the PG&E ER H&S Manager.

## 3.2 PMO PROJECT STAFF

The PMO provides program and project management services on behalf of PG&E and has the overall responsibility for management and administration of the construction and environmental remediation services provided for the Project.

### 3.2.1 PMO Site Operations Manager

Janet Newman – Arcadis – (949) 293-2445

The PMO Site Operations Manager is an authorized representative of the PMO who performs project management services on behalf of PG&E and is the liaison between PG&E and the Consulting and Construction Groups. The PMO Site Operations Manager's responsibilities include strategic sourcing, subcontractor coordination/management, implementation of Project controls, assessing Project risks and managing risk mitigation measures.

### 3.2.2 PMO H&S Coordinator

Mary-Catherine Goddard – Arcadis – (415) 535-7458

The PMO H&S Coordinator (HSC) is responsible for overall development/administration of the PMO H&S program. HSC will work with PMO contractors and subcontractors

during project planning and throughout the projects' lifecycles to ensure that relevant H&S procedures are understood and followed. The HSC will review PHSPs, perform spot checks and reviews JSAs, and assist with field audits to verify procedures are being implemented correctly. The HSC will review tailgate reports and work with personnel to identify improvements/lessons learned, attend routine H&S roundtable meetings. The HSC will perform site audits and assessments, assist with incident investigations, and participate on the PG&E Safety Council and on meetings/calls during H&S issues as they may arise.

### **3.3 TOPOCK CONSTRUCTION MANAGEMENT STAFF**

#### **3.3.1 Construction Manager Principal-in-Charge**

Daniel Talbot – Arcadis – (315) 391-2528

The Construction Manager Principal-in-charge (CMPIC) will be the primary point of contact for PG&E regarding all construction activities. The CMPIC is responsible for overall management of the Project, including the health and safety program. The CMPIC reports to the PG&E PM, and works with the PG&E SOM, Project CM and PG&E ERHSM to confirm that the H&S program is implemented in accordance with this PrHSP, PG&E H&S standards, and in agreement with project and regulatory requirements.

#### **3.3.2 Project Construction Manager**

Matthew Stenstrom – Arcadis – (775) 447-0036

The Project Construction Manager (PCM) is responsible for on-site management of construction activities, including implementation of the health and safety program. The PCM will also serve as the point of contact with the project's independent quality control/quality assurance (QA/QC) organization, and with PMO contracting/controls personnel for contract change management.

The PCM, along with the CHSM, oversees the implementation of all contractor H&S programs while on-site. Upon consultation with the CMPIC and PMO, the PCM is responsible for confirming and enforcing contractual H&S obligations, including using contractual enforcement mechanisms if a contractor is found to be non-compliant to contracted project H&S performance requirements.

The PCM will lead the regular high-level H&S project meetings described in Section 4.1. The PCM may also lead H&S inspections and assist in incident investigations. The PCM will report H&S performance information on a regular basis to CMPIC, the PG&E PM and PG&E SOM.

#### **3.3.3 Construction Site H&S Manager**

Matthew Michaelian – Advanced Environmental Group, Inc. – (949) 322-8335

## **Programmatic Health and Safety Plan**

### *Topock Final Groundwater Remedy Phase 1/ Phase 2 Construction Project*

---

The CHSM will serve as the manager leading the H&S effort. The CHSM prepared the PrHSP and will continually monitor site activities and prepare an addendum where necessary.

The CHSM or Project Site Safety Officer (PSSO) designee has the direct responsibility for day-to-day implementation of all H&S program practices across the Project. The CHSM or PSSO designee is the primary point of contact to all contractor, consultant, and observer H&S personnel and leads a parallel line of authority with contractor H&S managers, such that H&S performance maintains independence from production-oriented operational performance.

The CHSM reviews contractor H&S submittals (including contractor PHSPs, and subcontractor JSAs) prior to mobilization, performs ongoing reviews of work being performed against H&S requirements documented in this PrHSP and the appropriate contractor PHSP, confirms that all personnel have received site-specific H&S training, develops, and leads site-specific H&S training/orientation sessions, and leads incident investigations, including preparing incident investigation documentation. The CHSM may elect to delegate submittal review by the PSSO, as needed.

The CHSM or PSSO designee will also monitor site control (site entry and exit) through visitor management software to ensure that whoever arrives onto the project site is current with required training, has been issued and has donned required PPE, and has received medical releases/surveillance, where necessary.

The CHSM will oversee his/her staff of PSSO that will provide independent third-party daily field observations, and periodic scheduled health and safety audits. The CHSM will receive, review, and forward all required health and safety reporting, see Section 4.5. Incidents will be reported directly to the PCM.

The CHSM will take part in the morning H&S Principals Meetings described in Section 4.1.3.

#### **3.3.4 Project Site Safety Officer**

TBD (up to 3) – Advanced Environmental Group, Inc.

The Project Site Safety Officer's (PSSO) main responsibility will be to provide boots on the ground H&S oversight of project construction activities. PSSO will attend representative daily tailgate meetings with site personnel before work begins each day to discuss the potential hazards that may be encountered (with emphasis on those that may be encountered that particular day), safe work practices, required PPE, and emergency procedures. Ensure that PPE required or potentially required by the contractors PHSP is available and, when appropriate, worn by personnel working at the site. Help control access to the exclusion zone and/or work areas as defined. Aid staff in following established emergency evacuation routes to designated meeting. Other responsibilities are listed below:

## **Programmatic Health and Safety Plan**

### *Topock Final Groundwater Remedy Phase 1/ Phase 2 Construction Project*

---

- Coordinate the response to emergencies at the site, direct evacuation, or summon emergency assistance, as necessary.
- Conduct and document daily site walk-through inspections on a regular basis.
- Conducts monitoring of tasks and workers on-site, if needed
- Audit field documentation, including daily tailgate attendance sheets, visitor sign-in sheets, air monitoring data, and site walk-through inspection results.
- Notify the CHSM immediately regarding all health and safety problems, emergencies, injuries, illnesses, near-misses, and accidents.
- Assists the CHSM with incident investigations related to health and safety
- Remove contractor personnel from the project if the contractor is operating in an unsafe manner.
- Facilitate capture of site H&S data needed by project staff and PG&E.

### **3.4 CONTRACTOR H&S ORGANIZATION**

Most contractors have their own health and safety plans and/or company policies that are specific to their services. Contractor management is responsible for making sure their employees follow their company-specific health and safety plans and/or company policies. Contractor management is also responsible for assigning specific tasks to their employees; ensuring that their employees are properly trained and compliant with applicable regulations; and allocating sufficient time, materials, and equipment to safely complete activities in accordance with this PrHSP and their individual PHSP. A copy of their plans will be submitted for review and copies will be kept onsite (see section 1.2). The contractor organizational structure will be included for each contractor PHSP. Contractor H&S team size and scale will vary based on the scope of work a given contractor is tasked with, the inherent hazards associated with that scope, and the requirements described in the contractor's approved PHSP.

While engaged in work activities at this Site, contractors shall operate under their own health and safety plan, provided the health and safety requirements in any health and safety plan prepared by a contractor are as stringent as those contained in this PrHSP.

Hazards not listed in this PrHSP but known by the contractor, or known to be associated with a contractor's specialty, must be identified by and addressed in the contractor's PHSP, JSA, and during the daily tailgate meeting prior to beginning work. Any newly discovered hazards are to be reported immediately to the PCM. This PrHSP does not in any way relieve contractors from implementing their own safety practices applicable to the work they are performing.

All personnel assigned Site Safety Officer (SSO) responsibilities shall be qualified and expected to meet standards of professional level training, relevant experience, and professional certification. The standard for these expectations will be commensurate to the scope of the project, its duration, number of personnel, and potential for aspects of the task to present significant safety hazards. Examples of acceptable certifications are

Certified Industrial Hygienist, Certified Safety Professional, Occupational Health and Safety Technologist, and Construction Health and Safety Technician.

#### 3.4.1 Contractor Project Manager

The contractor's Project Manager (PM) is responsible for oversight and management of all aspects of their contracted project scope of work, including health and safety, quality assurance, personnel, contract management, schedule management, and change management.

The PM provides safety leadership by establishing the safety standard throughout the project by example and by holding all personnel assigned to this project accountable for their safety responsibilities. The contractor PM conducts periodic site inspections and participates in incident investigations.

#### 3.4.2 Contractor Project H&S Manager

The contractor Project Health and Safety Manager is the senior health and safety professional responsible for providing technical assistance to the contractor PM and on-site health and safety personnel. The Contractor Health and Safety Manager is responsible for the following:

- Developing and implementing contractor PHSP in compliance with this PrHSP, contract requirements, and applicable PG&E and government standards
- Reviews lower-tier contractor H&S submittals
- Assists Site Safety Officers in developing and reviewing project health and safety procedures, hazard analysis and other supporting documents
- Reviews analytic data, and other safety managerial professional services
- Conducts periodic inspections and audits of the project site, including subcontractors.

#### 3.4.3 Contractor Site Safety Officer (SSO)

The SSO's authority and responsibilities include, but are not limited to, the following:

- Participate in the daily tailgate meeting with the contractor's site personnel before work begins each day, regarding the contents of the PHSP and any approved revisions, the potential hazards that may be encountered (with emphasis on those that may be encountered that particular day), safe work practices, required PPE, and emergency procedures.
- Maintain a copy of the contractor's PHSP and any approved revisions at the site in an easily accessible area.
- Ensure that PPE required or potentially required by the PHSP is available and, when appropriate, worn by personnel working at the site. Each contractor and subcontractor will be responsible for providing respiratory or dermal PPE equipment, as described herein, to its own employees (Refer to Section 9.0).



## **Programmatic Health and Safety Plan**

### *Topock Final Groundwater Remedy Phase 1/ Phase 2 Construction Project*

---

- Control access to the exclusion zone and/or work areas.
- Establish emergency evacuation routes and designated meeting places in advance of each work activity and communicate this information during the daily tailgate meeting.
- Coordinate the response to emergencies at the site, direct evacuation, or summon emergency assistance as necessary (See section 15.0).
- Conduct and document daily site walk-through inspections.
- Conducts monitoring of tasks and workers on-site.
- Maintain field documentation, including daily tailgate attendance sheets, visitor sign-in sheets, air monitoring data, and site walk-through inspection results.
- As needed, accompanies employees to clinics or other health care providers to ensure proper care and evaluation of injured or ill employees.
- Notify the contractor PM, CHSM and PCM immediately regarding all health and safety problems, emergencies, injuries, illnesses, near-misses, and accidents.
- Assists the PM with incident investigations related to health and safety, including property damage.
- Assign an alternate SSO if the designated SSO will be absent.
- Suspend work activities when unsafe conditions or work practices are observed at the site and make required notification.
- Remove contractor personnel from the project if the contractor is operating in an unsafe manner and make required notifications.
- Notify the PCM of changes in site conditions or in the scope of field activities.
- Facilitate capture of site H&S data needed by project staff and PG&E.

#### **3.4.4 Contractor Site Supervisors**

The site supervisors (equivalent contractor personnel titles may include site managers, field geologists, field engineers, superintendents, or foremen) will be responsible for directing the work and schedule at their site, coordinating delivery of equipment and materials, and managing subcontractors performing work at their site.

Site supervisors have direct responsibility for ensuring that their teams are implementing their H&S program as they work, including completing H&S tailgate meetings, implementing the JSA process, and planning work such that it can be completed in a responsible and safe manner.

The Site supervisor's associated health and safety responsibilities include:

- Coordinating the activities of all field personnel, including the acknowledgment and implementation of this PrHSP and their PHSP.

## **Programmatic Health and Safety Plan**

### *Topock Final Groundwater Remedy Phase 1/ Phase 2 Construction Project*

---

- Providing oversight to the SSO and field personnel during work to be undertaken on-site.
- Ensuring that the assigned tasks are completed as planned and in a safe manner.
- Providing authority and resources necessary to ensure the implementation and management of safety procedures.
- Preparing reports and recommendations to the client and concerned field personnel.
- Ensuring that the SSO is adequately monitoring site safety conditions.

### **3.5 SUBCONTRACTORS**

Subcontractors will work under the direction of their respective site supervisor(s) and will be subject to all health and safety requirements set forth in their respective contractor PHSP, either their own, or the contractor PHSP that they are signing onto.

Subcontractor's compliance with this PrHSP requires that additional training and PPE appropriate for the craft, as described in the approved PHSP has been provided. Subcontractors with more than a few employees who will be expected to be onsite for an extended period will be expected to provide a site-specific health and safety plans, and job safety analyses. BBS elements will similarly be implemented.

### **3.6 SITE MONITORS AND VISITORS**

Site compliance monitors (Jacobs and subcontractors), other monitors (tribal, biological, archeological, and cultural) and visitors must coordinate their site transportation, site communications, and site activities with a site host or designee, and must comply with the requirements established. Site monitors and visitors are subject to applicable requirements of this PrHSP. Site-wide H&S requirements described in this PrHSP will apply to all personnel on-site, regardless of employer, specifically requirements regarding PPE requirements (Section 9.0) and site access (Section 13.0). Minimum expectations and requirements for monitors and visitors include:

- Compliance with the applicable provisions of this PrHSP and any applicable PHSPs, including training, PPE, and decontamination requirements.
- Remain in designated observer zones stationed outside of active work areas. Exceptions will be coordinated with site hosts and/or site supervisors.
- Compliance with direction from the site host, site supervisor, and/or SSO whenever there is a safety concern
- Exercise stop work authority. Every person at the site can stop the work of another person if working conditions or behaviors are considered unsafe. Site workers should notify the site host, site supervisor, and/or the SSO, if available, to stop work.

Safety and logistical requirements and operational plans for monitors and visitors will be coordinated with PG&E and host contractor.



## **4.0 COMMUNICATION, INSPECTION AND REPORTING REQUIREMENTS**

Communication is an essential part of implementing the project health and safety program. These specific guidelines must be followed to ensure project teams are communicating and reporting key elements involving health and safety.

### **4.1 MEETINGS**

The meetings listed below are a subset of the recurring meetings outlined in Specification Section 01 31 19.

#### **4.1.1 Daily Managers' Coordination Meetings**

Daily operational meetings will be held each morning for the Project Team managers to meet and discuss the high-level workplan for the day, coordinate between tasks and work sites, perform health and safety reviews, and review other matters. An H&S discussion and daily topic will be an agenda item for this meeting; however, this meeting will be focused on logistics and operations rather than H&S discussions. The PCM will be the designated coordinator to resolve conflicts between contractors and/or field crews working in the same area at the same time.

#### **4.1.2 Daily Construction Safety Tailgate Meeting**

A daily tailgate meeting will be held at the CHQ or each work site each morning prior to commencement of construction activities. The purpose of this meeting will be to communicate objectives for the day's work and any anticipated hazards to the crew members at each work area. Safe work procedures for minimizing these hazards will be discussed, roles and responsibilities reviewed, and crew members will be invited to contribute their health and safety concerns. JSA documentation will be reviewed and completed during tailgate meetings. Daily safety tailgate meeting attendance is mandatory, and recorded/documented by contractor's foreman, site supervisor and/or SSO.

#### **4.1.3 Daily Morning H&S Principals Meeting**

PG&E and contractor health and safety principals will meet each morning to discuss overall health and safety concerns for the day, any ongoing H&S issues, and general H&S performance. Topics covered will include anticipated hazards, safe work policies to address the anticipated hazards, and any health and safety concerns from the previous day's work or lessons learned. This meeting will also discuss upcoming H&S inspections and will serve as the follow-up milestone after completion of H&S inspections.

## **4.2 ON-SITE COMMUNICATION**

General communication practices that must be followed while working at the Project Site include:

- Active cellular telephone and/or radio service will be confirmed from each work area location before the start of work activities each day. AEG will work with PG&E

## **Programmatic Health and Safety Plan**

### *Topock Final Groundwater Remedy Phase 1/ Phase 2 Construction Project*

---

to confirm cellular, or radio service is available at all expected work locations and may install repeaters or similar infrastructure as required to ensure that all Phase 1/2 work locations have adequate service.

- Site personnel will use cellular phones and/or radios to maximize communications with emergency response units.
- Personnel in the work areas will attempt to remain in communication or within sight of the contractor SSO or their designee.

Contractor PHSP will provide specific communication methods to be implemented in the specific work zones associated with that PHSP, based on the constraints at these specific work zones. In the event of a catastrophic event, the contractor SSO will indicate the need to evacuate the site by verbal command or through radio or telephone communication. Emergency action plans and responses are discussed in Section 15.0.

### **4.3 INSPECTION AND H&S AUDITING**

Inspections and H&S auditing will be performed on a regular and spot basis. H&S auditing will be performed by the Project H&S audit team consisting of PG&E H&S personnel, the CHSM, and PSSO(s). PG&E personnel will perform audits as described in this PrHSP or in accordance with PG&E company standards. PMO personnel, or their representatives, may also perform audits as described in this PrHSP or in accordance with PMO requirements.

Project personnel will perform audits as per this PrHSP. Contractors will be responsible for internal inspections and audits as required by their approved PHSP. All site managerial personnel will be expected to participate in individual and team safety walk downs.

#### **4.3.1 Inspection**

Worksite inspection will be an important part of the health and safety program, ensuring site personnel are alerted of potential problems. See Table 4-1 below for minimum inspection requirements.

## Programmatic Health and Safety Plan

### Topock Final Groundwater Remedy Phase 1/ Phase 2 Construction Project

Table 4-1: Minimum Inspection Requirements

Frequency	Type	Responsible Person(s)	Details of Inspection
Monthly	First Aid Kits	Contractor SSO	Responsible Person (RP) will inspect to verify all items are complete, functional and that expiration dates have not passed. Re-stock, as necessary.
	Fire Extinguisher	Contractor SSO	RP will inspect fire extinguishers to confirm they are functional, pressure is within range (green), pins are in working order and yearly inspection label is updated and intact. Name of RP performing inspection and dates will be documented on tag attached. Yearly inspection of fire extinguishers will take place in September of each year by PG&Es contractor or independent third party.
	Truck Safety Inspection (TSI)	Qualified Contractor Personnel (monthly) Third-Party Consultant or PG&E Employee (as needed)	RP will perform a spot-check to determine vehicle compliance with US Department of Transportation (DOT) North American Standard Driver/Vehicle Inspection Level II criteria, and DTSC SB1257 Security Enhancements criteria, and is used to evaluate prime contractor or sub-contractor compliance with contract terms. (PG&E Utility Standard: ENV-9204S)
	Other Emergency Equipment	Contractor SSO	Contractor will list all required emergency medical equipment not shown in the PrHSP in their PHSP. RP will inspect per manufacture guidelines as described in their PHSP.
Weekly	Eyewash bottles, Portable Eyewash Stations and Showers	Contractor SSO	RP will inspect for functionality, water quality and record name and date on tag attached to equipment, weekly. Replace eyewash liquid if necessary or add bacteriostatic preservative agent to water as needed. Eyewash and emergency showers will be maintained as per manufacturers instruction.
	Automated External Defibrillator (AED)	Contractor SSO	RP will inspect for working status indicator, pads are in working condition, that connections are in good condition and that battery expiration dates have not elapsed. Follow manufactures maintenance instructions.
	Waste Storage Area	Contractor SSO / designated Contractor personnel	RP will ensure that Hazardous and Universal Waste are inspected as per the Waste Management Plan, which include inspection of: Hazardous waste containers for leaks or signs of deterioration, overall hazardous waste accumulation area. <i>Daily</i> inspections of hazardous waste tank systems are required, if applicable.
Daily	Work Area	Contractor SSO / designated Contractor personnel	RP will inspect general work area for general housekeeping, clear accessways and any other potential hazards.
	Vehicles and Tools	Contractor SSO / or Designated Contractor personnel	RP will inspect vehicles, tools, ladders, scaffolds, hoses, tubing, etc. for any defects that creates a potential for failure and injury. Any items found to be defective or damaged will be red tagged and replaced or fixed by trained and qualified personnel.
	Heavy Equipment	Contractor SSO/ Equipment Operator	RP will inspect equipment, such as, but not limited to, forklifts, bulldozers, backhoes, aerial lifts, soil graders, and cranes prior to use.
Prior to Use - Daily	Personal Protective Equipment (PPE)	Contractor SSO/ designated contractor personnel	RP will inspect PPE so that it is maintained and stored properly in a clean, sanitary manner. Any defective or damaged equipment, or equipment that has exceeded its useful life, shall be immediately removed from the work site to prevent use.

#### 4.3.2 Periodic Scheduled Field Audit

Regular H&S audits are an important tool in ensuring that contractors are in compliance with project H&S program requirements. The project construction H&S audit team will perform periodic scheduled field audits no less than every three months for the duration of the project. A contractor will be selected and notified prior to scheduled audit. The audit team will create an audit checklist that will be used in the field during review process. A general audit checklist is attached in Appendix D. The CHSM will prepare a checklist tailored to work type and task, which will be reviewed and approved by PMO and PG&E. Audit results will be reported and shared with the contractor and project team, and corrective action(s) will be assigned to a Responsible Person (RP). In addition to periodic scheduled field audits, CHSM or designee may elect to conduct “spot audits”.

#### 4.3.3 Records Audit

Records audits will be conducted to ensure that H&S training and medical qualifications of contractor and subcontractor personnel are in order. The project construction H&S audit team will perform H&S record audits no less than every three months for the duration of the project. A contractor will be selected and notified prior to scheduled audit. The audit team will create an audit checklist that will be used in the field during review process. The CHSM will prepare a checklist, which will be reviewed and approved by PMO and PG&E. Audit results will be reported and shared with the contractor and project team, and corrective action(s) will be assigned to a RP.

#### 4.3.4 Contractor/ Subcontractor Internal Audit

Contractors and subcontractors will perform internal audits in accordance with their PHSP and/or Corporate Health and Safety procedures at least once and no less than biannually. Subcontractors with limited scope, level of effort, or duration of work on-site may be exempted from this requirement at the discretion of the Construction Site H&S Manager. Audit results will be reported to project staff during H&S principals meeting.

### **4.4 REPORTING**

An effective safety culture encourages an environment where all project personnel feel they can raise safety-related issues without peer pressure or fear of reprisal. This includes notification, reporting, evaluation, and continuous correction of any safety incidents or unsafe conditions encountered during implementation of the project. This requires open and honest communication on safety, a non-punitive reporting process, and implementing appropriate personnel disciplinary actions only in response to the reported incident itself, and not in response of the act of reporting the incident.

Table 4-2 summarizes minimum required reporting including, types of reports, frequency, who is responsible, their frequency and contents. For more detailed information on specific reporting types, see below sections.

## Programmatic Health and Safety Plan

### Topock Final Groundwater Remedy Phase 1/ Phase 2 Construction Project

Table 4-2: Minimum Required Reporting Summary

Report Type	Frequency	Prepared by	Prepared for	Report Contents
Project H&S Report – PG&E Online Health Safety and Environmental Tool	Monthly	Prime Contractor or PCM	PG&E/PMO	The report will include, number of recordable incidents, lost workday incidents, restricted duty incidents, fatalities, vehicle incidents, serious preventable motor vehicle incidents, line strike incidents, all other incidents, perceived public issues, field hours worked, near hits, line strike near hits, best practices shared, and external regulatory inspections.
H&S Project Monthly Summary Report		CHSM	PCM/PGE/PMO	The report will include a H&S summary of the project.
H&S Metrics	Weekly	Contractor SSO	CHSM	The report will include leading and lagging H&S indicator metrics.
<p><b>Incident Event Types:</b></p> <p><b>SAFETY</b>  <u>(Noise Vibration [complaint, shutdown, damage],</u>  <u>Safety [property damage, minor Safety Incident, First Aid, OSHA Recordable, Fatality],</u>  <u>Utility Strike [Category 1-4]</u>  <u>Motor Vehicle [Minor, Major],</u>  <u>Near miss/hit [Low, Medium, High, Life Threatening]</u></p> <p><b>LAND &amp; ENVIRONMENTAL:</b>  <u>Compliance [High, Medium, Low]</u>  <u>Spill/ Release [Minor, Moderate, Major] Refer to CRAWP, Table 2.3-1</u></p> <p><b>See Appendix E for details on incident types</b></p>	Immediately or within 2 hours depending on severity	Contractor SSO or Contractor PM	PCM, CHSM	Verbal report of incident.
	Within 24-hours after Event occurs		PCM, CHSM, PG&E PM, PG&E ERHSM, PMO HSM, PMO SOM	The report will include Project Name, work area location, date, time, and duration; contact information of the reporting personnel; name(s) of all personnel involved in the incident; Names(s) of all personnel witnessing the incident; A description of the incident; The extent of known injuries or damage; Initial response or Corrective Action
	Within 5-days after Event occurs		PG&E PM	If required, complete investigation including root cause analysis
Observations	<p>A minimum of one Observation is required per 400 hours</p> <p>Observation reported within 2 hours</p>	Contractor SSO	CHSM	The report will include the Project Name, work area/ location, date, time, Name and contact information of the reporting personnel, A description of the event and Initial response or Corrective Action (if applicable).

#### 4.4.1 Incident and Near Miss/Hit Process Requirements

All personnel are required to immediately report any near miss/hit or incident (including, but not limited to noise/vibration, safety, utility strikes, motor vehicle incidents, compliance, or spills/release) in which they are involved or witness, to their supervisor (See Appendix E for details on incident types). All PHSPs are required to include an incident notification/reporting section that describes each contractor's notification process, including the required notification timeline, contractor internal chain of communications and contact information. The project event reporting guidance is provided in Table 4-3.

Table 4-3: Event Reporting Guidance

<p><u>Incident and Near Miss/Hit</u></p> <p><b>Immediately</b></p> <ol style="list-style-type: none"><li>1. Stop work</li><li>2. Stabilize the Situation (including getting medical attention, evacuating area, notifying owner of damage)</li><li>3. Verbally notify the following:<ol style="list-style-type: none"><li>a. Contractor's Supervisor</li><li>b. PG&amp;E on-site management (contact one of the following):<ol style="list-style-type: none"><li>i. David Diaz – (760) 903-3013, <a href="mailto:D3D6@pge.com">D3D6@pge.com</a>,</li><li>ii. Colton Garrard – (760) 422-7067, <a href="mailto:B4GY@pge.com">B4GY@pge.com</a>, or;</li><li>iii. John Glass – (415) 324-8530, <a href="mailto:f2q5@pge.com">f2q5@pge.com</a>.</li></ol></li><li>c. PCM (Arcadis)<ol style="list-style-type: none"><li>i. Matthew Stenstrom – (775) 447-0036, <a href="mailto:matthew.stenstrom@arcadis.com">matthew.stenstrom@arcadis.com</a></li></ol></li><li>d. CHSM (AEG)<ol style="list-style-type: none"><li>i. Matt Michaelian – (949) 322-8335, <a href="mailto:mmichaelian@aegconsultants.com">mmichaelian@aegconsultants.com</a></li></ol></li></ol></li></ol> <p><i>If there is a spill/release also contact:</i></p> <ol style="list-style-type: none"><li>e. QCM/SWWPP (Jacobs)<ol style="list-style-type: none"><li>i. Christina Hong – (626) 297-5292, <a href="mailto:christina.hong@jacobs.com">christina.hong@jacobs.com</a></li></ol></li></ol> <ol style="list-style-type: none"><li>4. Discuss with those involved and correct any immediate hazards.</li></ol> <p><b>Within 2 Hours</b></p> <ol style="list-style-type: none"><li>1. Email the project management team listed above and:<ol style="list-style-type: none"><li>a. PMO HSC (Arcadis)<ol style="list-style-type: none"><li>i. Mary-Catherine Goddard, (415) 535-7458, <a href="mailto:Mary-catherine.goddard@arcadis.com">Mary-catherine.goddard@arcadis.com</a></li></ol></li></ol></li></ol> <p><b>Within 24 Hours</b></p> <ol style="list-style-type: none"><li>1. Document event using your company's established system/procedure, including at a minimum:<ul style="list-style-type: none"><li>• Project Name, work area location, date, time, and duration.</li><li>• Contact information of the reporting personnel</li><li>• Name(s) of all personnel involved in the incident</li><li>• Names(s) of all personnel witnessing the incident</li><li>• A description of the incident</li><li>• The extent of known injuries or damage</li><li>• Initial response or Corrective Action</li></ul></li><li>2. Send event report via email within 24 hours to same notification chain as 2-hour. PMO HSC to notify PG&amp;E ERHSM (Lauren Baeta, (925) 655-7002, <a href="mailto:l6b7@pge.com">l6b7@pge.com</a>), cc: initial notification chain, with following details.</li></ol> <p><b>Within 5 Days</b></p> <ol style="list-style-type: none"><li>1. Complete investigation to determine root causes and develop corrective and preventative action.</li><li>2. A formal root cause analysis (RCA) must be submitted to PMO (Site Operations Manager &amp; HSC) who will send to PG&amp;E (ER Compliance and PM) for all major incidents (or for other selected events and near hits at PG&amp;Es discretion) as defined in the PG&amp;E ER Reporting Guidance.</li></ol> <p><b>Monthly</b></p> <ol style="list-style-type: none"><li>1. Contractor will report all safety and compliance incidents and near misses/hits to Prime contractor or PMO HSC by the 5<sup>th</sup> of each month, cc: PCM and CHSM. The PMO HSC will report to PG&amp;E via online Health and Safety &amp; Environmental Performance Management Tool by the 10<sup>th</sup> of each month.</li></ol>
--



PG&E Environmental Remediation Contractor Reporting Guidance and PG&E Contractor Safety and Compliance Event Reporting requirements and event definitions are included in Appendix E and Appendix F. The incident notification process included in each PHSP is required to be in compliance with these reporting requirements.

#### 4.4.2 Observations

As part of the behavioral based Health and Safety Program, observations will be collected and reported by project personnel. Observations are a proactive collection of safety hazards or H&S compliance issues that are identified and addressed in the field. Contractors and subcontractors are required to report observations at a frequency of one per 400 hours. Observation procedures are listed below. See Appendix G for PG&E ER Contractor Observation Guidelines.

Table 4-4: Observation Reporting Guidance

<p><u>Observation</u></p> <p><i>Immediately</i></p> <ol style="list-style-type: none"><li>1. Stop or pause work (if needed)</li><li>2. Discuss with those involved and correct any immediate hazards.</li><li>3. Provide positive feedback for best behaviors and practices</li></ol> <p><i>Within 2 Hours</i></p> <ol style="list-style-type: none"><li>1. Contractor H&amp;S SSO to notify the CHSM via email or using software application implemented, with following details:<ul style="list-style-type: none"><li>• Project Name, work area/ location, date, time</li><li>• Name and contact information of the reporting personnel</li><li>• A description of the event</li><li>• Initial response or Corrective Action (if applicable)</li></ul></li></ol> <p><i>Within 24 Hours</i></p> <ol style="list-style-type: none"><li>1. Communicate relevant events and teaching moments at least daily to:<ul style="list-style-type: none"><li>• All on-site personnel during tailgate meetings</li></ul></li></ol> <p><i>Within 5 Days</i></p> <ol style="list-style-type: none"><li>1. Document using your company's system/procedure, if established</li></ol> <p><i>Monthly</i></p> <ol style="list-style-type: none"><li>1. Contractor SSO will report all observations to the CHSM by the end of each month. CHSM will compile and report monthly observations to PCM and PMO HSC by the 5<sup>th</sup> of each month. The PMO HSC will report to PG&amp;E via online Health and Safety &amp; Environmental Performance Management Tool by the 10<sup>th</sup> of each month.</li></ol>
---



#### 4.4.3 H&S Metrics

CHSM will capture H&S data, perform data analysis, and report the results and indicators as part of monthly reporting. Contractors will provide weekly updates. An example of a general H&S metrics form is provided in Appendix H. The H&S metrics form may be revised to capture other relevant metrics and/or integrated into the H&S software application. The following are indicators that may be collected:

Leading indicators

- Observations
- Near misses to identify weakness, implement corrective actions where needed
- Percent of employee training completed vs expected
- Percent of jobs preplanned
- Percent of compliant/safe conditions

Lagging indicators

- Injury frequency and severity
- Incidence rate
- OSHA recordable
- Loss workdays
- Regulatory citations

#### 4.5 MANAGING H&S PROGRAM

A secure cloud-based software application will be implemented to assist AEG in collecting, managing, and reporting data for the H&S program. The application will capture and facilitate the following program components: 1) Meetings, 2) Incident and Near Miss/Hit Reporting, 3) Audits/Inspections and Corrective Actions, 4) BBS – Observations, 5) Training, and 6) H&S Metric Reporting.

## **5.0 GENERAL RULES AND CONDITIONS**

### **5.1 GENERAL SITE ACCESS**

Upon initial entry to the site, all project personnel, visitors, and observers shall report to the project CHQ and receive an initial orientation. As appropriate to anticipated tasks and duration on site, they will receive a safety orientation and/or review this PrHSP and sign the certification page acknowledging that they have read, understand, and agree to comply with the provisions. Project personnel and visitors will also be required to have read, understand, and agree to comply with the provisions set forth in the appropriate contractor PHSP(s) and other relevant safety information prior to entering the support or exclusion zone or a specific active work zone.

After personnel, visitors, and observers have received initial training and signed an acknowledgment form, all subsequent Site visits require mandatory check-in and checkout. Daily attendance will be captured via a hard copy roster or an electronic attendance system. The primary location for Site attendance check-in and check-out is at the CHQ, or upon PG&E approval may be captured in real time on a mobile device at another pre-determined location by the contractor. For visitors or observers that do not have ISNetwork badges, a temporary pass/badge will be issued at the CHQ by the Visitor Management Group once a person has been cleared for entry.

The minimum PPE for all workers, compliance monitors, other monitors and visitors within designated construction work zones is OSHA Level D (reference Table 9.2); the only exceptions from Level D are the check-in/CHQ office area, and in vehicles while driving between Site locations. Specific work zones may require additional PPE and training, as described in Sections 9.0 & 10.0.

In general, due to safety considerations at the construction site, visitors will be prohibited from entering designated construction work areas, including, but not limited to exclusion zones, and contamination reduction zones, unless otherwise authorized by PG&E, the on-site contractor site supervisor, or SSO. If a visitor requests entry into an active work zone, the construction team will evaluate the situation and may make appropriate adjustments (such as ceasing an activity during the observation) to allow safe entry by the visitor. Visitors will be required to don the necessary PPE prior to entry. All visitors who will be entering a work zone will be required to attend the daily safety meeting for those activities or receive a safety briefing from the SSO prior to entering the work zone.

For specific site entry procedures, see section 13.0

### **5.2 TOPOCK COMPRESSOR STATION ACCESS**

The TCS has additional requirements for unescorted personnel access. Daily operations at the TCS have special H&S considerations related to gas transmission operations and are in addition to the Project scope of work. As such, TCS requires additional specific H&S training and additional PPE (fire-resistant pants and long sleeve shirt, or coveralls) prior to personnel access within the Station boundary, as described in Sections 9.0 & 10.0. Project personnel must complete specific PG&E Compressor Station safety training

to work within the Station without an escort. Personnel who have not received this training must be escorted by a PG&E representative at all times while within the Compressor Station.

All project personnel, monitors, and visitors working within TCS will have their primary check-in and check-out occur at the CHQ. Project staff working within TCS must have supervisor or designee submit roster to TCS front office at the beginning of each work shift.

The Project will be coordinated with the TCS supervisors to minimize potential impact on TCS operations, and construction personnel access to the Station will be limited to personnel essential to complete planned construction at the Station. All contractors scheduled to work within the limits of the TCS must include in their PHSP detailed H&S guidance, rules, and procedures specific to the hazards associated with working in the TCS facility.

### **5.3 CODE OF SAFE PRACTICES**

Personnel employed by or representing PG&E, contractors, or external stakeholders will be responsible for complying with their respective organization's code of conduct. Portions of PG&E's Code of Safe Practices relevant to this project are attached in Appendix I. Unacceptable employee conduct and/or violation of a project rule or requirement will be managed as a contractual issue and may result in individual denial of access to the work area or project facilities.

General examples of unacceptable employee conduct and/or rule violation are as follows:

- Abusing equipment, vehicles, or other property.
- Operating equipment or vehicles without authorization and proper qualification.
- Failure to operate equipment or vehicles in the manner specified by the manufacturer (including proper maintenance and repairs).
- Willful negligence that results in violations of health and safety or project rules or requirements.
- Behaving in a culturally inappropriate or disrespectful manner.
- Behaving in a verbally or physical threatening manner, fighting
- Engaging in horseplay of any kind.
- Sexual harassment, including making inappropriate comments or displaying inappropriate behavior toward an individual's sexual or gender orientation.
- Improperly using, or failure to use, toilet facilities.
- Violating the Site security rules.
- Littering, not using trash receptacles, or otherwise creating unsanitary conditions.
- Smoking, using tobacco, or eating in prohibited areas.

- Possessing, when not authorized, project, or other person's property or services, or theft of the same.
- Altering, damaging, or mutilating public, project, or another person's property.
- Reporting or badging for other employees or other identification misrepresentation.
- Refusing to submit to drug and alcohol screening or testing or other similar inspections.
- Possessing or using alcoholic beverages, controlled substances, or weapons on any project.
- Sleeping on the project.
- Not reporting an accident or health and safety incident, no matter how minor.

## **5.4 OTHER SAFE WORK PRACTICES**

### **5.4.1 Buddy System**

All site personnel should use the buddy system whenever possible and a buddy system is mandatory in high heat (see section 6.3.1), hazardous work areas and remote locations with no real time communication via cell phone or radio. Work should be conducted with a buddy who is able to:

- Provide his or her partner with assistance.
- Observe his or her partner for signs of chemical or heat exposure.
- Periodically check the integrity of his or her partner's PPE.
- Notify the Supervisor or others if emergency help is needed.

The buddy system alone may not be sufficient to ensure that help will be provided in an emergency. At all times, workers in the Exclusion Zone should be in line-of-sight contact or communications contact with the Supervisor or backup person in the Support Zone.

### **5.4.2 Illumination**

All scheduled outdoor work should be planned to occur during daylight hours, if possible. If work must be performed during hours of darkness or inside buildings, the contractor will ensure that additional lighting is provided to meet the requirements of CCR, Title 8, §5192 & §3317. A minimum 5-foot candles of light are required in work areas. All lighting will be in accordance with Mitigation Monitoring and Reporting Program (MMRP), 2018 sections BIO-2f, CUL-1a-7.

### **5.4.3 Spill Containment**

#### **5.4.3.1 Fuel Handling**

During construction activities, there is a potential for spills of fuel during fueling operations for construction equipment. Fueling methods will comply with Safe Fueling and Handling

## **Programmatic Health and Safety Plan**

### *Topock Final Groundwater Remedy Phase 1/ Phase 2 Construction Project*

---

Policy (Remedy Standard Operating Procedure (SOP)-02) (Construction Remedial Action Work Plan (CRAWP), Appendix B, 2015), and project-specific Fuel Handling Procedure developed for each unique project area. Prior to fueling, the surrounding area will be inspected for possible ignition sources and flammable materials. Potential ignition sources will be removed, covered, or protected prior to fueling. All fueling on Site will include the use of secondary containment or drip pans under fuel nozzles to prevent spills. In the event of a spill, the PG&E Site Operations Manager/Sr. Environmental Inspector must be notified immediately.

#### *5.4.3.2 Well Installation*

During well installation, there is a potential for spills of liquids used for well drilling and well development. The procedures for spill prevention, containment, and control to be used during well installation are similar to those that must be used for monitoring well development, purging, and sampling. Those procedures are provided in SOP-A13. SOP-A13 can be found in Appendix A, Sampling and Monitoring Plan, Operation and Maintenance Manual Volume 2 (CH2M Hill, 2014). In the event of a spill, the PG&E Site Operations Manager/Sr. Environmental Inspector must be notified immediately refer to event reporting (section 4.4.1).

#### *5.4.3.3 Hazardous Waste*

Should any hazardous waste (including contaminated soil) be spilled, the procedures for spill reporting and response outlined in the Sections 4.7 and 4.8 of the Soil Management Plan (CRAWP, Appendix L, Nov. 2015) and Waste Management Plan (CRAWP, Appendix R, Nov. 2015), will be followed.

## 6.0 TASK HAZARDS ANALYSIS AND REQUIRED CONTROL MEASURES

Major safety and health concerns that are anticipated during primary tasks at this Site are briefly noted in Table 6-1, as a summary of the hazard identification process. A detailed list of anticipated work tasks is presented in Appendix J. Contractors and subcontractors will further review specific tasks and identify anticipated safety and health hazards to be presented in the PHSP or JSAs. These documents will be reviewed and approved by the CHSM, PG&E and PMO, as required.

Although, some tasks will be performed within areas where chemical contamination may be present in soil and groundwater, most tasks will be performed in areas that are not contaminated; and personnel will not come in direct contact with potentially contaminated soil or groundwater. All project chemical hazards are presented in Section 7.0.

PG&E introduced a hazard-identification tool that must be used to identify the presence of high energy hazards before and during work. The PG&E energy wheel and handouts are attached in Appendix V PG&E Contractor Handbook.

The table below outlines, from a macro level view, key safety and health hazards listed for the primary work tasks to be performed on-site. PHSPs key health and safety hazards will be more specific to work being performed, detailed and task driven.

*Table 6-1: Summary of Key Safety and Health Hazards for Remedy Construction*

<p><b>Mobilization and Site Preparation</b></p>	<ul style="list-style-type: none"> <li>◆ <i>Biological and environmental hazards (e.g., heat stress)</i></li> <li>◆ <i>Electrical hookup and power distribution</i></li> <li>◆ <i>Exposure to overhead and buried utilities</i></li> <li>◆ <i>Heavy equipment operation, including minor earthwork to prepare site staging areas</i></li> <li>◆ <i>Loading and unloading of facility equipment, mobilizing heavy equipment, and construction materials</i></li> <li>◆ <i>Manual loading and unloading of materials</i></li> <li>◆ <i>Slip, trips, and falls</i></li> </ul>
<p><b>Well Installation</b></p>	<ul style="list-style-type: none"> <li>◆ <i>Airborne dust</i></li> <li>◆ <i>Biological and environmental hazards (e.g., heat stress)</i></li> <li>◆ <i>Elevated work and suspended loads</i></li> <li>◆ <i>Exposure to contaminated groundwater</i></li> <li>◆ <i>Heavy equipment operation, strike personnel or equipment, crush hazards from equipment or import material</i></li> <li>◆ <i>Loud machinery operation (noise)</i></li> <li>◆ <i>Manual loading and unloading of materials</i></li> <li>◆ <i>Non-permit confined space work</i></li> <li>◆ <i>Pinch points between fixed and moving equipment</i></li> <li>◆ <i>Pressurized system hazards, flying debris, whipping hoses, injection hazard</i></li> <li>◆ <i>Slip, trips, and falls</i></li> <li>◆ <i>Struck by and caught within parts or equipment</i></li> <li>◆ <i>Work on uneven ground</i></li> <li>◆ <i>Work in or near active roadways, struck by traffic</i></li> <li>◆ <i>Work in low-visibility conditions around equipment</i></li> <li>◆ <i>Work in and around active underground utilities</i></li> </ul>



## Programmatic Health and Safety Plan

### Topock Final Groundwater Remedy Phase 1/ Phase 2 Construction Project

<b>Pipeline Installation</b>	<ul style="list-style-type: none"> <li>♦ Airborne dust</li> <li>♦ Biological and environmental hazards (e.g., heat stress)</li> <li>♦ Burn hazards from High Density Polyethylene fusing equipment</li> <li>♦ Electrical hazards</li> <li>♦ Elevated work and suspended loads</li> <li>♦ Excavation/trench hazards, collapse, traffic hazard, hazardous atmosphere</li> <li>♦ Exposure to contaminated soil (within AOCs)</li> <li>♦ Heavy equipment operation, strike personnel or equipment, crush hazards from equipment or import material</li> <li>♦ Manual loading and unloading of materials</li> <li>♦ Non-permit confined space work</li> <li>♦ Overhead utilities</li> <li>♦ Pinch points between fixed and moving equipment</li> <li>♦ Pressurized system hazards, flying debris, whipping hoses, injection hazard</li> <li>♦ Slip, trips, and falls</li> <li>♦ Struck by and caught within parts or equipment</li> <li>♦ Work in low-visibility conditions around equipment</li> <li>♦ Work in or near active roadways, struck by traffic</li> <li>♦ Work on uneven ground</li> <li>♦ Work in and around active underground utilities</li> <li>♦ Work within the active Compressor Station</li> </ul>
<b>Material Import/Export</b>	<ul style="list-style-type: none"> <li>♦ Biological and environmental hazards (e.g., heat stress)</li> <li>♦ Heavy equipment operation, strike personnel or equipment, crush hazards from equipment or import material</li> <li>♦ Manual loading and unloading of materials</li> <li>♦ Slip, trips, and falls</li> <li>♦ Work in or near active roadways, struck by traffic</li> <li>♦ Work in low-visibility conditions around equipment</li> </ul>
<b>Electrical and Controls Systems Installation</b>	<ul style="list-style-type: none"> <li>♦ Biological and environmental hazards (e.g., heat stress)</li> <li>♦ Electrical contact, shocks and burns</li> <li>♦ Elevated work and suspended loads</li> <li>♦ Ergonomics, muscle strain and repetitive motion.</li> <li>♦ Heavy equipment operation, strike personnel or equipment, crush hazards from equipment or import material</li> <li>♦ Manual loading and unloading of materials</li> <li>♦ Overhead utilities</li> <li>♦ Slip, trips, and falls</li> <li>♦ Work within the active Compressor Station</li> <li>♦ Work in and around active underground utilities</li> </ul>
<b>Earthwork, Grading, Retaining Wall Construction</b>	<ul style="list-style-type: none"> <li>♦ Airborne dust</li> <li>♦ Biological and environmental hazards (e.g., heat stress)</li> <li>♦ Elevated work and suspended loads</li> <li>♦ Excavation/trench hazards, collapse, traffic hazard, hazardous atmosphere</li> <li>♦ Falls, on ground or on equipment ladders</li> <li>♦ Heavy equipment operation, strike personnel or equipment, crush hazards from equipment or import material</li> <li>♦ Manual loading and unloading of materials</li> <li>♦ Overhead utilities</li> <li>♦ Pressurized system hazards, whipping hoses, injection hazard</li> <li>♦ Struck by and caught within parts or equipment</li> <li>♦ Slip, trips, and falls</li> <li>♦ Work in low-visibility conditions around equipment</li> <li>♦ Work in or near active roadways, struck by traffic</li> <li>♦ Work around active underground utilities</li> <li>♦ Work within the active Compressor Station</li> </ul>



## Programmatic Health and Safety Plan

### Topock Final Groundwater Remedy Phase 1/ Phase 2 Construction Project

---

<b>Process Facility Construction and Buildout</b>	<ul style="list-style-type: none"><li>♦ <i>Airborne dust</i></li><li>♦ <i>Biological and environmental hazards (e.g., heat stress)</i></li><li>♦ <i>Elevated work fall hazard</i></li><li>♦ <i>Heavy equipment operation, strike personnel or equipment</i></li><li>♦ <i>Hot work (welding and/or cutting)</i></li><li>♦ <i>Manual loading and unloading of materials</i></li><li>♦ <i>Materials movement hazards struck by</i></li><li>♦ <i>Overhead utilities.</i></li><li>♦ <i>Pressurized system hazards (pneumatic systems and concrete pumping equipment), whipping hoses</i></li><li>♦ <i>Slips, trips, and falls</i></li><li>♦ <i>Work in low-visibility conditions around equipment</i></li><li>♦ <i>Work in or around active natural gas transmission operations</i></li><li>♦ <i>Work in or near active roadways, struck by traffic</i></li><li>♦ <i>Work around active underground utilities</i></li></ul>
---	--

## 6.1 HAZARD ANALYSIS RISK RANKING AND JSA

A preliminary evaluation and hazard risk ranking of the common hazards expected during the Project is presented in Table 6-2. Project hazard risks can be assessed by assigning a relative value (1-4) to match the severity, frequency, and probability of each type of expected hazards. The numerical products of these parameters are then multiplied by an integer (1-4) scaled to the number of personnel that may be exposed to such a hazard (1 meaning a low number of employees will be exposed to hazard and 4 meaning the high number of employees will be exposed to the hazard). The resulting product provides a rough ranking of hazards anticipated, to ensure focused efforts, and appropriate dedication of resources for controls.

## Programmatic Health and Safety Plan

### Topock Final Groundwater Remedy Phase 1/ Phase 2 Construction Project

Table 6-2: Hazard Risk Matrix

Type of Hazard	Severity score	Frequency score	Probability score	Number of employees	RISK Potential	Description of potential hazards
Physical	2	4	2	4	48	Slips/trips/falls and walking and working surfaces
	3	2	2	2	24	Falls from heights > 6 ft.
	4	2	1	3	24	Heavy equipment - struck by
	4	2	1	2	16	Vehicle traffic - project site and related travel
	2	4	1	2	16	Excavations - personnel exposure to collapse/engulfment
	2	3	2	2	24	Manual lifting - muscle strain
	3	2	2	1	12	Drilling activities - pinch points, struck by
	2	2	1	2	8	Structural and equipment fires - fueling, materials storage
	4	1	2	1	8	Utility strikes
	2	2	1	1	4	Pressurized systems; hydraulics, pumps, conveyance piping
3	1	1	1	3	Cranes, boomed equipment, hoisting	
Biological	2	1	2	2	8	Snakes
	3	1	1	1	3	Bloodborne pathogen
Environmental	3	1	1	3	9	Severe weather
	3	1	1	3	9	Wildfires
	3	1	1	2	6	Lightning strikes
	3	4	4	4	192	Heat stresses
	2	1	1	2	4	Cold stress
	1	4	2	4	32	Noise from equipment

(Construction Health and Safety Plan, PIVOX, 2015) Revision 1 - 6/26/18

The planning and hazard assessment process continues into the individual job task through the use of JSA, which is synonymous with Activity Hazard Analysis (AHA) or Job Hazard Analysis (JHA).

While some activities will be covered by the hazard analysis sections in this PrHSP, as the task planning process and lessons-learned evolve during this project, new JSAs will be developed to address these changes, as necessary.

JSAs describe each step of the activity, the types of exposures, accidents or incidents that can be anticipated, and the control measures that must be implemented before and during the activity. Employee input regarding their knowledge of the activity, hazards and controls will be solicited. PG&E ER encourages and expects JSAs in the field to be revised by adding newly recognized site-specific job steps, hazards, and controls as part of the daily tailgate meeting. The JSA must be reviewed and signed by every member of

the activity, whenever a change is made to it, and as deemed necessary by safety or project management.

Contractors are also required to evaluate and include identified high energy hazard sources and controls in their JSA, AHA or JHAs. See PG&E's High Energy Wheel pictured to the right for reference.

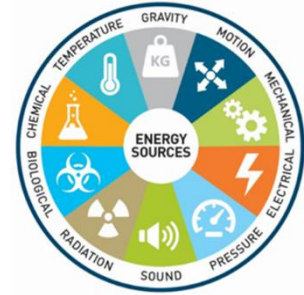

## 6.2 PHYSICAL HAZARDS

This subsection presents the primary safety issues posed by known or potential physical hazards on the Site. All personnel on-site may potentially be exposed to one or more of these physical hazards during the course of work. Many of these hazards will appear obvious to experienced Site personnel and, therefore, exhaustive explanations of each have not been provided with this PrHSP. Brief descriptions of the expected primary physical hazards at this Site that may be associated with construction activities are provided below with personal protective equipment or other control requirements, applicable Cal/OSHA regulations.

### 6.2.1 Fire – Structural, Equipment, Fueling and Materials Storage

Open flames and spark producing equipment are prohibited in areas where flammable liquids or gases are used or may be generated. Open flames or other ignition sources are prohibited within a minimum of 35 feet where flammable liquids or gases may accumulate. Any rags or other waste materials soaked with combustible or flammable liquid must be disposed of in a closed container.

Tobacco smoking shall be limited to a designated smoking area determined by the project leads and properly posted. Smoking is prohibited during fueling operations. An electrical bond must be maintained between containers when flammable liquids are transferred, and equipment must be grounded. Equipment shall be shut down during fueling and, as appropriate, equipment shall have spark arrestors. Heavy equipment and vehicles will each be equipped with a fire extinguisher. Instrumentation used in potentially flammable atmospheres shall be rated intrinsically safe for Class I atmospheres.

All Hot Work requires a permit, see section 6.2.9.1.

All trained field personnel are authorized to use a fire extinguisher if the fire is small and does not endanger their health or life, is caused only by project operations, and is within their ability to control. Fire extinguishers will be placed at pre-determined locations at each work area.

## 6.2.2 High Voltage and Overhead Utility Lines

The Project includes construction of high voltage (12kV) power distribution. Specialized skills are required from personnel directly working near high voltage power. The JSAs for this work will need to address minimum training requirements, specialized PPE, lock-out/tag-out, and work zone access control when working in and around high-voltage electrical equipment. All electricians who make connections of greater than 100 volt-amps who work for C-10 contractors must be certified.

The Project will encompass work near overhead utilities. PHSPs and JSAs for this work will need to address procedures for personnel and equipment that need to pass beneath overhead electrical power lines, prescribe pre-operation walkdowns, utility owner coordination and oversight, safe vertical clearances for under passing equipment, and vertical and horizontal clearances for overhead power line during operations.

In all cases, work near overhead utilities will be conducted in coordination with the utility owners(s). For all equipment, a minimum of 10 feet clearance from all high voltage lines, up to a maximum voltage of 50,000 volts, must be maintained at all times. For lines exceeding 50,000 volts, the following table lists the minimum clearances for boom-type equipment:

*Table 6-4: Power Line Clearance*

<b>Nominal Voltage (Phase to phase)</b>	<b>Minimum Project Clearance (feet)</b>
600 to 50,000	10
50,000 to 75,000	11
75,000 to 125,000	13
125,000 to 175,000	15
175,000 to 250,000	17
250,000 to 370,000	21
370,000 to 550,000	27
550,000 to 1,000,000	42

(CCR, Title 8, §1612.1)

The site personnel shall be aware of increased electrical hazard during high humidity or rainy conditions.

## 6.2.3 Excavation and Trenching

### 6.2.3.1 Outside TCS

Pipeline construction will require crossing of existing underground utilities. Many of these utilities are large high-pressure natural gas transmission lines. Gas transmission pipeline crossings are described and designed in the project plans, however, pipeline installation

## **Programmatic Health and Safety Plan**

### *Topock Final Groundwater Remedy Phase 1/ Phase 2 Construction Project*

---

and other contractors that will have to cross these lines will have to describe associated safety and observation requirements in their PHSP and/or JSA.

All contractors are required to provide a Golden Shovel Standard certification and adhere to their Dig-In Prevention Program approved by PG&E before starting any applicable intrusive civil, excavation and trenching work activities. Contractor will follow all PG&E work standards for utility locating and excavation including, but not limited to, PG&E Utility Work Procedure 4412P-05 and Utility Standard ENV-9201S, See Appendix K and Appendix L.

To minimize the potential hazards associated with underground utilities the following activities should be implemented prior to mechanical excavation:

- Review available drawings showing subsurface utilities
- Dig Alert/Underground Service Alert (811) shall be contacted to identify underground utility locations.
- Establishing a USA ticket for the project and having utilities mark the known location of their utilities. The ticket will be kept active throughout the project's duration and re-checked every 28 days.
- Contracting a utility survey firm to conduct an underground geophysical survey of the entire Site work area.
- Locating appropriate emergency shut-off valves and electrical boxes (if any).
- Manual potholing to expose utilities. Perform potholing under the presence and supervision of the owner's (PG&E's) representative and respective utility representatives. Hand digging will be required in areas where buried facilities are located.
- As an option to potholing and if approved by PG&E, "lines of evidence" approach may be used as follows:
  - Three lines of evidence are required for utility locations, the three lines are:
    - 1) Notifying Dig Alert 48 hours prior to drilling;
    - 2) Utility survey using ground penetrating radar;
    - 3) Hand auger to ~5 feet prior to drilling.
- Identifying and documenting the size, type, depth, and direction of all utilities within the remediation area.
- Educating field personnel regarding subsurface utilities.
- Conducting field-meets with utility owners and completing excavation work under utility owner oversight, as necessary.

In an excavation where oxygen deficiency or the presence of harmful gas could be anticipated, excavation will be treated as a confined space as described in Section 6.2.9.2. Employees who enter excavations that have the potential to cave in and those 5

## **Programmatic Health and Safety Plan**

### *Topock Final Groundwater Remedy Phase 1/ Phase 2 Construction Project*

---

feet or more in depth will be protected by a system of shoring, sloping of the ground, benching, or other equivalent means. A safe means of access/egress will be located within 25 lateral feet of employees working in excavations 4 feet or more in depth. Excavated material will be placed as far as possible from the edge of the excavation, but never less than 5 feet from the edge, if possible. A daily inspection of excavations will be made, by a competent person, to identify and eliminate conditions that could result in possible cave-ins, failure of support systems, hazardous atmospheres, or other unsafe conditions (CCR, Title 8, §1541(k)). A Cal/OSHA construction activity permit is required for construction of trenches or excavations that are 5 feet or deeper and into which a person is required to descend. (CCR, Title 8, §1540, §1541)

Contractors will utilize spotters during excavations to emphasize close visual inspection when working near utilities. The result of all utility location work, including the geophysical survey and potholing will be documented and provided upon request.

#### **6.2.3.2 Within TCS**

Excavation within the TCS fence line shall adhere to requirements presented above in Section 6.2.3.1 and the following additional requirements.

Contractors conducting excavation and trenching work within the TCS, can expect to encounter unknown underground utilities. While every attempt will be made to locate and identify underground utilities, compressor station protocol requires all intrusive work inside the station fence line will be performed by hydro vacuum or hand excavation methods (and per contract drawing C-00-01, Note 5).

Perform potholing under the presence and supervision of the owner's (PG&E's) representative and respective utility representatives.

Hydro vacuum and wet soil drying/stockpiling procedures need to be approved by PG&E prior to implementation. Any proposed alternative excavation approaches must be approved by PG&E prior to implementation. PG&E's specific TCS excavation guidance is provided in Appendix M.

Contractors will coordinate with PG&E representatives to provide on-site observation of excavations in the vicinity of the underground gas or electric transmission infrastructure and for all work within the TCS (and outside of TCS is required).

#### **6.2.4 Struck By / Falling Objects**

Workers are at risk of being pinned (caught) in between construction vehicles and walls or stationary surfaces, struck by swinging equipment, crushed beneath overturned vehicles, or many other similar accidents. When working near a public roadway, workers are additionally exposed to being struck by vehicles. Improper operation of heavy vehicles poses a life-threatening danger to construction workers. Always follow safe practices to minimize injuries and save lives. Always install, use, and maintain vehicle back-up alarms. Station flaggers behind vehicles that have obstructed rear views. Keep non-essential



## **Programmatic Health and Safety Plan**

### *Topock Final Groundwater Remedy Phase 1/ Phase 2 Construction Project*

---

workers away from areas of vehicle use. Keep workers away from temporary overhead activities. Place barriers and warning signs around hazardous operations and public roadways. Workers should never put them self between moving or fixed objects. Contractor and subcontractor workers, observers, and visitors shall wear required fluorescent vests when on project Site.

Workers are at risk from falling objects when they work around cranes, scaffolds, overhead electrical line work, etc. There is a danger from flying objects when using power tools, or during activities like pushing, pulling, or prying, that can cause objects to become airborne. Flying/falling objects can also roll off rooftops, or be accidentally kicked off walkways, scaffold platforms, etc., if they are not properly constrained.

#### **6.2.5 Moving Machinery Parts and Equipment Guarding**

Guards are required on machines, parts, and components which create hazardous revolving, reciprocating, running, shearing, punching, pressing, squeezing, drawing, cutting, rolling, mixing, or similar action, including pinch points and shear points, if not guarded by the frame or the machine or by location. All machine guards shall be appropriate for the hazards involved, secured in-place, constructed of substantial material, and have surfaces free of hazardous projections. Guards shall be provided with hinged or removable sections where it is necessary to change belts, make adjustments, or for the administration of lubricants. In addition, personnel shall not wear loose clothing or jewelry and avoid entanglement of long hair (CCR, Title 8, §4002, §4184).

#### **6.2.6 Control of Hazardous Energy including Lock-out Tag-out (LOTO)**

Machinery, equipment, and utility lines (gas and liquid lines) capable of movement, electrocution or flow shall be stopped and the power source de-energized or disengaged, and if necessary, the movable parts shall be mechanically blocked or locked to prevent inadvertent movement during cleaning, servicing, installation, or adjusting operations. If machinery must be able to move during servicing, use extension tools to protect employees from the movement. Controls or energy sources shall be secured by lock in the "off" position and marked with accident prevention signs and/or tags. Removal of locks and/or tags may only be completed by an authorized person once work on the system or equipment has been completed and confirmed safe for operation. A written lock out/tag out plan and activity log must be developed and implemented by contractors prior to activity. (CCR, Title 8, §3314)

#### **6.2.7 Slips, Trips and Falls**

Personnel will minimize the potential for slips, trips, falls by providing clear footing. Installation of temporary walkways, where required, will provide a safe pathway. Workers shall be aware of slippery conditions, uneven surfaces, existing piping/conduit, and maintain good housekeeping within their respective work areas. Permanent roadways, walkways, and material storage areas shall be maintained free of dangerous depressions, obstructions, and debris. (CCR, Title 8, §3273)



### 6.2.8 Ergonomics

Extreme caution shall be exercised during operations involving the manual handling or lifting of heavy objects. Implement good lifting techniques. It is important to stretch muscles, prior to actual lifting, climbing, other physical work, and after meal breaks. General programmatic controls shall be implemented when risk of musculoskeletal disorders is recognized. Programmatic controls include:

- Training;
- Early reporting of symptoms by workers; and,
- Ongoing surveillance and evaluation of injury, health, and medical data.

(CCR, Title 8, §5110)

### 6.2.9 Work Processes Requiring Permits

Permits must be obtained for all “high-hazard” work processes identified during Daily Tailgate Safety Meetings. Obtaining and understanding the proper permits for work identified as hazardous, contributes to the creation of an incident-free and injury-free workplace. Determination for the need of other work permits will be determined on a case-by-case basis, depending on the job tasks.

A site-specific permit is required for hot work and confined space entry, as described below.

#### 6.2.9.1 Hot Work - Welding, Torch Cutting, Brazing, Grinding

Hot work, including welding, shall not be performed in potentially flammable or explosive atmospheres without prior monitoring using a combustible gas indicator (CGI). The general atmosphere, lower explosive limit (LEL) shall be below 10%. Before welding is performed on containers (i.e., transformer tanks, tanks, or pipes), the internal atmosphere shall be purged with inert gas (nitrogen) until the oxygen level (O<sub>2</sub>) is below 8% and LEL is below 10%. Readings will be taken with a properly calibrated 4-gas meter that has been bump tested with calibration gas. Fire watch shall be present at each welding/torching/brazing activity. Hot work permit shall be filled out by contractor SSO before work commences. Compressed gas vessels, if required, shall be secured, and used with the manufacturer's recommended valves and fittings. Unused cylinders shall be secured and capped. (CCR, Title 8, §1537 & §5150)

Hot work requirements and permit documentation shall be included in the PHSP of any contractor expecting to perform hot work. During hot work task planning, the contractor is to prepare a hot work permit in accordance with their approved PHSP and submit to the permit to the PCM. The PCM will route the permit to the required review personnel, and the contractor may not initiate any hot work without an approved permit.

**6.2.9.2 Confined Space Entry**

Site areas shall be considered confined spaces if they meet conditions defined in the OSHA confined space entry regulation (CCR, Title 8, §5157).

There are two types of confined spaces: non-permit required confined space and permit-required confined space. Non-permit required confined space is defined as a confined space that does not contain or, with respect to atmospheric hazards, have the potential to contain any hazard capable of causing death or serious physical harm. Permit required confined space (permit space) refers to a confined space that has one or more of the following characteristics:

1. Contains or has a potential to contain a hazardous atmosphere;
2. Contains a material that has the potential for engulfing an entrant;
3. Has an internal configuration such that an entrant could be trapped or asphyxiated by inwardly converging walls or by a floor which slopes downward and tapers to a smaller cross-section; or
4. Contains any other recognized serious safety or health hazard.

According to CCR, Title 8, §5157 (b) a hazardous atmosphere refers to an atmosphere that may expose employees to the risk of death, incapacitation, impairment of ability to self-rescue, injury, or acute illness from one or more of the following causes:

1. Flammable gas, vapor, or mist in excess of 10 percent of its LEL;
2. Airborne combustible dust at a concentration that meets or exceeds its LEL;
3. Atmospheric oxygen concentration below 19.5 percent or above 23.5 percent;
4. Atmospheric concentration in excess of the permissible exposure limit (PEL) [note: an atmospheric concentration of any substance that is not capable of causing death, incapacitation, impairment of ability to self-rescue, injury or acute illness due to its health effects is not covered by this provision]; or
5. Any other atmospheric condition that is immediately dangerous to life or health.

Confined space entry regulations and permit documentation shall be included in the PHSP of any contractor expecting to perform any confined space entry (permitted or not). If a permit-required confined space entry is required, the contractor is to prepare a draft permit in accordance with their approved PHSP and submit to the PCM. The PCM will route the permit to the required review personnel, and the contractor may not initiate any without the approved permit.

### 6.2.10 Work in and Around Vehicular Traffic and Control

Much of the work will take place on or adjacent to roads. PHSP and JSAs for this work will need to address compliance with traffic control requirements, work zone delineation/visibility, traffic barriers, and access/egress to work zones from public roads. Contractor will implement traffic control, planning, and coordination measures in accordance with the local requirements. Personnel working on or near roads shall follow all Traffic Control Plans as part of Caltrans Encroachment permits, where implemented. In absence of, or in addition to such plans, contractors are required to provide traffic control in accordance with CA Manual on Uniform Traffic Control Devices (CA MUTCD). Contractors will provide trained traffic control personnel and equipment including flaggers, signage, and delineation, in accordance with a Traffic Control Plan or when necessary to control vehicular traffic around work areas to ensure worker safety. It is the responsibility of the contractors to develop a travel plan to safely access project work areas and such plan shall be communicated to staff. All personnel working in, and around vehicular traffic are required to wear high visibility vests as per Section 9.0 PPE.

Project personnel shall follow all laws pertaining to safe motor vehicle use or equipment operation on local roads and highways. Extreme caution shall be used while traveling around project locations including areas impacted by traffic control plans as general public vehicular and pedestrian traffic are anticipated.

## 6.3 ENVIRONMENTAL HAZARDS

### 6.3.1 Heat Illness

Heat stress in workers is the highest ranked hazard at the Site. Climatic conditions at the project site may generate high ambient environmental temperatures exceeding 70°F from spring through fall and reaching temperatures greater than 100°F during the summer months of June, July, August, and September. For consistency it is recommend that contractors, subcontractors, observers, and visitors employ the OSHA/ National Institute for Occupational Safety and Health (NIOSH) Heat Safety Tool.

<https://www.cdc.gov/niosh/topics/heatstress/heatapp.html>

Contractors and subcontractors shall establish, implement, and maintain, an effective heat illness prevention plan. The written Heat Illness Prevention Plan (CCR, Title 8, §3395 (i)) shall, at a minimum, contain:

- (1) Procedures for the provision of water and access to shade;
- (2) The high heat procedures;
- (3) Emergency Response Procedures; and,
- (4) Acclimatization methods and procedures.

Heat stress is the accumulation of heat in the body, leading to a potentially dangerous rise in body core temperature. Heat stress is a precursor to heat illness which is a serious medical condition resulting from the body's inability to cope with a heat load. This can lead to recognized forms of heat stress and the associated symptoms listed below:

**Heat Rash** - can be caused by continuous exposure to hot and/or humid air. The condition is characterized by a localized red skin rash and reduced sweating.

**Rhabdomyolysis** - can be caused by continuous exposure to hot and/or humid air. The condition is characterized by muscle cramps/pain, weakness, exercise intolerance and abnormally dark urine.

**Heat Cramps** - can be caused by profuse perspiration with inadequate fluid intake and salt replacement. This condition is characterized by muscle spasm and pain in the extremities and abdomen.

**Heat Exhaustion** - a mild form of shock can be caused by substantial physical activity in heat and profuse perspiration without adequate fluid and salt replacement. The symptoms include weak pulse; shallow breathing; pale, cool, moist skin; profuse sweating; dizziness; and fatigue.

**Heat Stroke** - the most severe form of heat stress can be fatal. The symptoms include red, hot, dry skin; body temperature of 104° F or greater; no perspiration; nausea; dizziness and confusion; strong rapid pulse; coma; and death.

Although the use of PPE will reduce the risk of exposure to chemical hazards, PPE may contribute to the potential for workers to experience heat related illnesses. For example, workers wearing a Tyvek suit with boots, gloves, hardhat and powered air purifying respirators (PAPR) or half face air purifying respirators may be exposed to physiological stresses that raise metabolic and core temperatures. All Site personnel shall be responsible for reporting these symptoms, in either themselves or in another Site worker, to the contractor SSO.

### Protective Measures

In order to minimize the potential for heat stress at the Site, the following protective measures shall be implemented by all contractors and subcontractors, observers and visitors.

The following general controls and recommendations will be captured in contractors and subcontractors PHSPs and used on-site:

**Training:** All contractors and subcontractors will review and be trained in the contents of their Heat Stress Prevention Program and compliance will be enforced by supervisors. In addition, heat stress prevention protocols (i.e., hydration and rest periods) and emergency response information (site locations and emergency cool down procedures) will be reiterated during pre-work safety tailgates meetings.

## **Programmatic Health and Safety Plan**

*Topock Final Groundwater Remedy Phase 1/ Phase 2 Construction Project*

---

**Acclimatization:** Employees who are not accustomed to working in the heat will be given ample time to acclimate to the high heat conditions and monitored thoroughly using the buddy system and by observance from the contractor SSO. On average, acclimatization peaks in most people within 4-14 days of work. For new workers (not acclimatized), the schedule shall be no more than 20% of the usual duration of work in the heat on day 1 and no more than a 20% increase on each additional day. Employees who have been away from the site for more than a week will need time to reacclimatize unless they have been working in another similarly hot environment elsewhere.

**Shade:** A well-ventilated shaded area that blocks direct sunlight will be made available for rest and cool down periods when the ambient air temperature is above 80°F. The shaded area shall include seating and ample shade for all workers. Potable and reasonably cool drinking water (< 59°F) will be available for consumption. To prevent dehydration, 1 cup (8 oz.) of potable water will be made available for employee consumption for every 15 minutes of work per employee. The use of electrolyte beverages and electrolyte and salt supplements that can be added to water are also encouraged only where necessary. Use of electrolyte and salt supplements should only be used in moderation if crew are experiencing heat cramps or hyponatremia. Avoid salt tablets.

**High-Heat Procedures:** When the ambient air temperature is equal to or exceeds 95°F, high heat safety protocols will come into effect. Some of these safety precautions will include: mandatory buddy system and observation of employees, monitoring of workers vital signs by contractor SSO (body temperature and pulse), increased communications between workers and supervisors, mandatory preventative rest and rehydration in shaded area (10 minutes of rest for every 2 hours of work, minimum required by Cal/OSHA), and reiteration of emergency response procedures and training in pre-work safety meeting.

**Work/Rest Program:** A work/rest program is recommended to control core body temperature to levels that reduce risk to heat related illness. The NIOSH work/rest schedule is based on air temperature and humidity (heat index), with adjustments for direct sunlight. Use OSHA Heat Illness application for current heat index. [https://www.osha.gov/SLTC/heatillness/heat\\_index/heat\\_app.html](https://www.osha.gov/SLTC/heatillness/heat_index/heat_app.html) Temperaturehtml corrections will be made when an upgrade in PPE is required (i.e., Level C – Respirators and Tyvek). See table 6-3 below.

## Programmatic Health and Safety Plan

### Topock Final Groundwater Remedy Phase 1/ Phase 2 Construction Project

Table 6-3: NIOSH Work Rest Schedule for Workers Wearing Normal Clothing (NIOSH Criteria for a Recommended Standard, Occupational Exposure to Heat and Hot Environments)

Adjusted Temperature <sup>1</sup> (°F)	Light Work Minutes Work/Rest	Moderate Work Minutes Work/Rest	Heavy Work Minutes Work/Rest
90	Normal	Normal	Normal
91	Normal	Normal	Normal
92	Normal	Normal	Normal
93	Normal	Normal	Normal
94	Normal	Normal	Normal
95	Normal	Normal	45/15
96	Normal	Normal	45/15
97	Normal	Normal	40/20
98	Normal	Normal	35/25
99	Normal	Normal	35/25
100	Normal	45/15	30/30
101	Normal	40/20	30/30
102	Normal	35/25	25/35
103	Normal	30/30	20/40
<b>104</b>	<b>Normal</b>	<b>30/30</b>	<b>20/40</b>
105	Normal	25/35	15/45
106	45/15	20/40	<b>Caution<sup>2</sup></b>
107	40/20	15/45	<b>Caution</b>
<b>108</b>	<b>35/25</b>	<b>Caution</b>	<b>Caution</b>
109	30/30	<b>Caution</b>	<b>Caution</b>
110	15/45	<b>Caution</b>	<b>Caution</b>
111 or greater	<b>Caution</b>	<b>Caution</b>	<b>Caution</b>

<sup>1</sup> Adjusted temperature includes solar load and humidity adjustment to outdoor temperature:

**Solar Load:**

Full Sun (no clouds): Add 13°

Partly cloudy/overcast: Add 7°

No shadows visible/work is in the shade/night: no adjustment

**Humidity:**

10%: Subtract 8°

20%: Subtract 4°

30%: No adjustment

40%: Add 3°

50%: Add 6°

60%: Add 9°

<sup>2</sup> High Levels of heat stress; Consider rescheduling activities.



**Monitoring:** Area and personal heat stress monitors may be required to evaluate heat stress exposures. Personal heat stress monitors and thermometric assessments assist in monitoring core temperatures. As core temperatures rise, more rest is prescribed.

**Engineering Controls:** Contractors and subcontractors where feasible shall implement engineering controls to prevent heat stress illness. Examples of controls include spot cooling, air-conditioned car or cab, misters, fans.

### 6.3.2 Cold Stress

Low ambient temperatures increase the heat lost from the body to the environment by radiation and convection. In cases where the worker is standing on frozen ground, the heat loss is also due to conduction. Wet skin and clothing, whether because of water or perspiration, may conduct heat away from the body through evaporative heat loss and conduction. Thus, the body cools suddenly when outer clothing is removed, if the clothing underneath is perspiration soaked. Movement of air across the skin reduces the insulating layer of still air just at the skin's surface. Reducing this insulating layer of air increases heat loss by convection. Non-insulating materials in contact or near-contact with the skin, such as boots constructed with a metal toe or shank, conduct heat rapidly away from the body. Certain common drugs, such as alcohol, caffeine, or nicotine, may exacerbate the effects of cold, especially on the extremities. These chemicals reduce the blood flow to peripheral parts of the body, which are already high-risk areas because of their large surface area to volume ratios. These substances may also aggravate an already hypothermic condition.

#### Precautions

- Be aware of the symptoms of cold-related disorders, and wear proper, layered clothing or the anticipated fieldwork. Appropriate rain gear is a must in wet weather.
- Consider monitoring the work conditions and adjusting the work schedule using guidelines developed by the U.S. Army (wind-chill index) and the National Safety Council (NSC).
- Wind-Chill Index (<https://www.weather.gov/safety/cold-wind-chill-chart>) is used to estimate the combined effect of wind and low air temperatures on exposed skin. The wind-chill index does not take into account the body part that is exposed, the level of activity, or the amount or type of clothing worn. For those reasons, it should only be used as a guideline to warn workers when they are in a situation that can cause cold-related illnesses.
- NSC Guidelines for Work and Warm-Up Schedules can be used with the wind-chill index to estimate work and warm-up schedules for fieldwork. The guidelines are not absolute; workers should be monitored for symptoms of cold-related illnesses. If symptoms are not observed, the work duration can be increased.
- Persons who experience initial signs of immersion foot, frostbite, and/or hypothermia should report it immediately to their supervisor/PM to avoid progression of cold-related illness.
- Observe one another for initial signs of cold-related disorders.



Obtain and review weather forecast – be aware of predicted weather systems along with sudden drops in temperature, increase in winds, and precipitation.

### 6.3.3 Noise

The use of motorized equipment and handheld power tools pose a potential for exposure to noise levels above the levels considered safe by Cal/OSHA. Monitoring for occupational noise exposure shall be conducted for each representative task that involves use of a powered tool or equipment, and whenever the construction SSO deems such monitoring is necessary.

A portable handheld Type 2 Sound Level Meter (SLM) shall be used for surveying general work areas. All noise measurements shall be taken in the "Hearing Zone" of the individual being monitored (i.e., within a radius not to exceed 12 inches from the closest ear or in most direct proximity to the noise source). All measurements used for comparison with compliance noise levels shall be made on the A-weighted scale, slow response.

When noise monitoring data shows levels equivalent to 85 decibels A-scale (dBA) or a higher time weighted average (TWA) for an 8-hour work shift, hearing protection will be required as per the Cal/OSHA standard for occupational noise exposure (CCR, Title 8, §5095 - §5099).

*"Hearing Protection Required"* areas may be designated by the construction SSO where noise levels may exceed the action level (AL) of 85 dBA based on an 8-hour TWA, or in areas where work has commenced but monitoring has not been conducted and noise levels may be expected to exceed the AL. Designated employees, whose job assignments require them to be in the vicinity of high noise levels above the AL shall be provided hearing protection.

## 6.4 SAFE USE OF CONSTRUCTION TOOLS AND EQUIPMENT

### 6.4.1 Tool Use

Tools are required to be maintained and safely used on this Site. The following are general safe work practices:

- It is important to always use the right tool for the job.
- All power tools shall be plugged into Ground Fault Circuit Interrupter (GFCI). Use all tools in the manner intended and/or prescribed.
- Review of operating instructions for all tools and equipment prior to use is MANDATORY.
- Modification of use or design must be in accordance with the written instructions or permission of the manufacturer.

## **Programmatic Health and Safety Plan**

### *Topock Final Groundwater Remedy Phase 1/ Phase 2 Construction Project*

---

- Inspect safety devices before every use, especially guards on cutting devices. Do not remove or circumvent guards or other safety devices on tools.
- Inspect other tools and equipment before use and do not use defective equipment.
- Identify/tag defective equipment per organization protocols such that they cannot be inadvertently brought back into service.

(CCR, Title 8, §1699 & §1707)

#### **6.4.2 Ladders**

All portable ladders (A-frame, step ladders, extension ladders, etc.) shall be inspected before each use and maintained in good condition. Non-conductive ladders shall be used on-site. If ladder is found to be defective (weakened, cracked, broken, missing steps, broken side rails, etc.), it shall be discarded. Extension ladders shall be placed at the proper angle (the horizontal distance from the top support to the foot of the ladder is one-quarter of the working length of the ladder [the length along the ladder between the foot and the top support]), secured, and extended at least 3 feet above landing. Always maintain a 3-point (two hands and a foot, or two feet and a hand) contact on the ladder when climbing. Keep your body near the middle of the step and always face the ladder while climbing. (CCR, Title 8, §3276)

#### **6.4.3 Scaffolds**

Scaffolding shall be erected and dismantled by trained and qualified personnel. Training shall comply with CAL/OSHA's most current regulation. All scaffolds shall be green tagged once competent person completes scaffold, and before any work atop scaffold proceeds. (CCR, Title 8, §1637-1648, §1653, §1655)

#### **6.4.4 Mechanical and Heavy Equipment**

To minimize potential mechanical hazards, the following requirements shall apply:

- Only qualified operators will be allowed to use mechanical equipment.
- All equipment is to be operated in accordance with manufacture's written instructions and/or manuals.
- Equipment shall not be modified or operated out of specified limits without written permission from the manufacturer and the health and safety manager for the project.
- DO NOT use a piece of equipment, which has been tagged out of service! Do not remove red tags without authorization from the person placing the tag or the person responsible for the repairs.
- Designate routes at the site for mobilization and use of heavy equipment and trucks.

- Do not stand near or out of sight of the operator using concrete-breaking and earthmoving equipment—keep at a safe distance.
- Must wear a rated fluorescent safety vest (minimum Class II) when working around industrial trucks, forklifts, etc.
- A qualified spotter must work with equipment operators and truck drivers during operations conducted within high traffic or pedestrians/worker areas or structures. Spotter is responsible for communicating operating clearances, equipment navigation aid, and hazards to the equipment operator. The operator is required to heed the direction of their spotter and may not operate their machine without their spotter present and visible.
- If it becomes necessary to speak with an equipment operator, make eye contact and acknowledgement with both the operator and the spotter then signal your intentions before approaching the equipment.
- Mechanical equipment must be inspected daily before operation to verify safe working order.
- Heavy equipment inspections shall be documented. Note all discrepancies and tag out equipment that may be dangerous to operate.
- Machinery shall not be serviced, repaired, or adjusted while in operation, nor shall oiling of moving parts be attempted, except on equipment that is designed or fitted with safeguards to protect the person performing the work.

(CCR, Title 8, §1590, §1592, §1593, §1596-§1599, §8459)

## **6.5 SPECIAL HAZARDS**

The wide scope of the Project can be expected to result in a number of special hazards that will be unique to the various construction methods, locations, and site-specific constraints. This PrHSP does not list every hazard associated with the wide variety of construction work that will occur during the Project. Instead, this PrHSP only includes general site hazards that can be expected to be encountered during the Project. The PHSP for specific contracted work will be required to describe special hazards unique to the scoped work, and the goal of the JSA process is for construction team members to carefully consider their work, the hazards associated with their work, and the means to avoid and/or mitigate those hazards. The following discussion is not meant to serve as a complete discussion of hazards from which to plan work.

### **6.5.1 Work in or Near Steep Topography**

The nature of the operations in and near steep slopes makes it necessary to consider the safety issues associated with personnel and equipment around them. Slope stability is a matter of concern during the excavation. All heavy equipment used on uneven terrain should be equipped with roll over protection to protect the operator. The contractor will utilize previously prepared geotechnical reports (if available) in its technical approach to the excavation in or near steep slopes and include the technical approach in their PHSP.

The technical approach will be approved by the contractor's geotechnical expert and the contractor SSO prior to the start of excavation in or near steep slopes.

The PG&E Slope Safety Standard is to be followed and is included with this PrHSP as Appendix N.

#### 6.5.2 Work in remote locations

Many locations in the Project area are physically remote or relatively inaccessible to other Remedy construction sites. When working at remote locations, emergency contact service may be compromised. Personnel are to avoid working alone, ensure phone or radio service is adequate before beginning operations, and the PHSP and JSA for this type of work will describe a personnel tracking/contact protocol.

Cellular phone service is known to be poor in specific work locations. All personnel are required to test cellular phone service at a work location prior to beginning work and implement an alternative communication procedure if cellular phone service is found to be unreliable. Alternative communications procedures will be detailed in the PHSP and JSA for the work, and may include use of 2-way radios, utilization of a 3-person buddy system, or use of satellite phones.

#### 6.5.3 Flash Floods

Short-duration heavy rainfall with little warning is typical of the climate in the Topock area. Personnel working in washes and other natural drainage features may be caught in flash floods caused by sudden rainfall. The PHSP and /or JSA for this work will need to address seasonal weather patterns, access/egress to work sites, weather monitoring, evacuation triggers, and work zone evacuation procedures. Reference section 15.10.6 for emergency response guidance.

#### 6.5.4 Work near or overwater

Contractor's and other site staff employees who perform their job duties over or near water shall follow the minimum operation requirements designed to prevent injury or fatality from falling into the water (as required by CAL/OSHA §1602). This includes the following:

- Crews will be provided with Personal Flotation Devices (PFD) that are marked Type II, PFD and U.S. Coast Guard approved, when within 6 feet of the water... Prior to and after each use, the buoyant work vests or life preservers shall be inspected for defects which would alter the strength of buoyancy. Defective units shall be taken out of service.
- 30" ring buoys with at least 150 feet of 600-pound capacity line shall be provided and readily available for emergency rescue operations. This includes all watercraft or along the riverbank when working within 6 feet of the water's edge, unless the

employee is secured to a fall restraint system limiting a fall into the water. Distance between ring buoys shall not exceed 200 feet.

- At least one lifesaving skiff shall be immediately available at locations where employees are working over or adjacent to water.
- All watercrafts must be equipped with emergency supplies (e.g., mooring lines, signaling equipment, boat hooks, radios, phones, fire extinguisher, PFDs). All watercrafts must have appropriate navigational lighting.
- Boat operators must be competent in the operation of the boat, safe handling, and emergency procedures for operating in high winds/stormy conditions, etc.

#### 6.5.5 Protection from wildfire smoke

Contractor's and other site staff employees who perform their job duties outdoors where the Air Quality Index is 151 or greater and where the employer should reasonably anticipate that employees may be exposed to wildfire smoke are required to abide by CCR, Title 8, §5141.1.

## **6.6 BIOLOGICAL HAZARDS**

Biological hazards such as insects (i.e., scorpions, spiders, bees, wasps), plants (i.e. scorpion weed), animals (i.e. rattlesnakes) exist on the site. If an animal is present, contact biologist representative to handle moving. Supplemental information on these Biological Hazards is included in Appendix O. Each contractor will address these concerns and means to prevent exposure in their respective PHSPs.

Other biological hazards that exist on-site include, mold, bacteria and viruses which can cause infections or disease such as valley fever or COVID-19. Each contractor and subcontractor will be responsible for complying with their company's COVID-19 Protection Policy (CPP) and any additional PG&E requirements while performing work onsite. Specific to the Topock Compressor Station, face coverings, where required, must be flame resistant. Additional information on Valley fever is included in Appendix O. Contractors to include Biological hazard and controls in their PHSP.

## **7.0 CHEMICAL HAZARDS**

This section contains information concerning hazards due to chemical substances known or suspected to exist in site soil and/or groundwater. Contractors, subcontractors, observers, and visitors may potentially be exposed to one or more of the health hazards listed during the course of work.

The field activities anticipated at the Site present potential chemical hazards. Actual exposures to these hazards are dependent on the specific work task and location, weather conditions, level of protection utilized and personnel work habits. Control of these hazards will be mitigated through hazard identification, training, and use of PPE, air and medical monitoring and the supervision of Site activities.

### **7.1 ESTIMATE OF THE LEVEL OF HEALTH RISKS**

The most significant chemical hazards present are chromium (VI), lead, dioxin, and furans. Exposures to chemicals may occur as a result of the release of gases, vapors, dusts, mists or fumes during construction activities.

### **7.2 ACTION LEVELS**

Using a conservative screening-level approach, to ensure workers are not exposed to chemicals at levels that exceed the OSHA regulatory PELs, the AL for contaminants are, for the most part, set at ½ of the PEL.

To minimize the potential for worker exposure, the action levels in Table 7-3 will be used to take proper corrective actions, where necessary. Personnel involved in work on the Site will always use PPE meeting United States Environmental Protection Agency (USEPA) Level based protection, as described in Section 9.0 of this PrHSP.

Note that preparation of this PrHSP was based, in part, on the chemical compounds identified through laboratory analysis, predictable byproduct compounds, and other contaminants that are expected to exist at the Site. If other chemical substances are later identified on the Site, then additional health hazard summary information shall be included with this PrHSP as an addendum or in contractors PHSP.

The applicable PELs are defined by Cal/OSHA. The majority of PELs represent time-weighted average values based on an 8-hour workday, 40-hour work week. Other exposure limits (EL)s are expressed as short-term exposure limit (STEL) values, which, generally, represent limits not to be exceeded for time periods longer than 15 minutes or 30-minutes. Certain substances have a "Skin" notation following the PEL/STEL, which dictates that the overall exposure to a substance is enhanced by skin, mucous membrane and/or eye contact exposure. Some substances have a ceiling limit, designated by the letter "C" which shall not be exceeded at any time during a work shift. The PEL, STEL, "Skin" notation and ceiling limits are further discussed in Appendix P.



### 7.3 AREAS OF CONCERN AND CHEMICALS OF CONCERN

AOCs were identified and mapped following site investigation and sampling efforts by CH2M Hill / Jacobs (Tables 3-1 to 3-35, PG&E, 2018). Site AOCs and extent of Chromium VI in groundwater are shown on Figure 2.

Data used to determine maximum chemical concentration detected in soil are from Arcadis (Table 1, Arcadis, 2010)<sup>3</sup> and PG&E (Tables 3-1 to 3-35, PG&E, 2018)<sup>4</sup>. The main chemical of concern in groundwater is Chromium (VI). Data used to determine maximum Chromium (VI) concentration range in groundwater are from Arcadis 1<sup>st</sup> Quarter 2018 Interim Measures Performance Monitoring and Site-Wide Groundwater Monitoring Report, April 2018, table 3-1. Maximum concentrations of Chromium (VI) recorded in groundwater varied from background levels to 62,000 µg/L. Chemicals of concern (COC) for the Site are listed in Table 7-1. A summary for each COC is provided in Appendix P which lists primary health hazards associated with exposure to these substances along with applicable exposures requiring first aid (Center for Disease Control (CDC), NIOSH). Occupational Exposure Limit (OEL)s are listed, including OSHA PELs, NIOSH recommended exposure levels (REL)s, American Conference of Governmental Industrial Hygienists (ACGIH) threshold limit values (TLV)s and Immediately Dangerous to Life and Health (IDLH) levels.

Table 7-1: Project Chemicals of Concern

<b>CHEMICALS OF CONCERN</b>			
<b>Area Maximum Concentration Found</b>	<b>CAS No.</b>	<b>Compound</b>	<b>Maximum Concentration Detected in On-Site Samples</b>
AOC-13	7440-38-2	Arsenic	50 mg/kg
AOC-4 & AOC-12	1332-21-4	Asbestos	<0.1%
AOC-10	50-32-8	Benzo (a) Pyrene Equivalent	8.2 mg/kg
AOC-10	1333-82-0	Chromium VI	2,700 mg/kg (soil)/ 62,000 ug/L (groundwater)
SWMU-1	-	Dioxin and Furans	12,000 ng/kg
AOC-10	7439-92-1	Lead	11,000 mg/kg
AOC-14	7439-97-6	Mercury	180 mg/kg
AOC-4	-	Polycyclic Aromatic Hydrocarbons (PAH)	12 mg/kg
AOC-4 (inside fence line)	-	Polychlorinated Biphenyl (PCB) (Total)	13.8 mg/kg
AOC-4	87-86-5	Pentachlorophenol	8.9 mg/kg
AOC-13	-	Total Petroleum Hydrocarbon (TPH)-Diesel	8,500 mg/kg
Groundwater	1333-82-0	Chromium VI	36,000 µg/L

(CAS) = Chemical Abstract Service Number.

<sup>3</sup> PG&E Topock AOC 4 Health and Safety Plan, 2010

<sup>4</sup> PG&E Topock Compressor Station Soil Investigation Data Package, 2018



## 7.4 EXPOSURE LEVELS

Both Cal/OSHA and Federal OSHA regulate occupational exposures to COCs. Where available, Cal/OSHA PELs and ceiling values are referenced; otherwise, OSHA values are used. In addition, NIOSH and ACGIH both publish RELs, TLVs, ceiling exposure and IDLH values, respectively.

ALs based on airborne total dust concentrations were developed for each COC. The ALs were based on the maximum concentrations of the specific contaminants found in the soil (Table 7-1), expressed as 15-minute average concentrations. Table 7-2 lists the minimum dust levels to reach OEL or AL thresholds for individual COCs, based on the expected maximum soil concentration (Table 7-1).

This approach applies a conservative dust AL across all work areas, based on project-wide maximum concentrations detected in previous site assessments.

*Table 7-2: Calculated Minimum Airborne Dust Limits to Reach OEL or AL for Individual COCs*

<b>COC (Occupational Exposure Limit [OEL])</b>	<b>Equation: <math>EL \times 10^6</math> <u>Concentration in Soil</u></b>	<b>=</b>	<b>Minimum Total Dust Required to reach OEL</b>
Arsenic (AL)	$\frac{0.005 \text{ mg/m}^3 \times 10^6 \text{ mg/kg}}{50 \text{ mg/kg}}$	=	100 mg/m <sup>3</sup>
Benzo (a) Pyrene (equivalent) (PEL)	$\frac{0.2 \text{ mg/m}^3 \times 10^6 \text{ mg/kg}}{8.2 \text{ mg/kg}}$	=	24,390 mg/m <sup>3</sup>
Chromium VI (AL)	$\frac{0.0025 \text{ mg/m}^3 \times 10^6 \text{ mg/kg}}{2,700 \text{ mg/kg}}$	=	0.93 mg/m <sup>3</sup>
Dioxins and Furans (REL <sup>5</sup> )	$\frac{40 \text{ pg/m}^3 \times 10^6 \text{ mg/kg}}{0.012 \text{ mg/kg}}$	=	3.3 mg/m <sup>3</sup>
Lead (AL)	$\frac{0.03 \text{ mg/m}^3 \times 10^6 \text{ mg/kg}}{11,000 \text{ mg/kg}}$	=	2.7 mg/m <sup>3</sup>
Mercury (PEL)	$\frac{0.025 \text{ mg/m}^3 \times 10^6 \text{ mg/kg}}{180 \text{ mg/kg}}$	=	139 mg/m <sup>3</sup>
PAH (REL)	$\frac{0.001 \text{ mg/m}^3 \times 10^6 \text{ mg/kg}}{12 \text{ mg/kg}}$	=	83.3 mg/m <sup>3</sup>
PCB (PEL)	$\frac{0.5 \text{ mg/m}^3 \times 10^6 \text{ mg/kg}}{13.8 \text{ mg/kg}}$	=	56,180 mg/m <sup>3</sup>
Pentachlorophenol (PEL)	$\frac{0.5 \text{ mg/m}^3 \times 10^6 \text{ mg/kg}}{8.9 \text{ mg/kg}}$	=	56,000 mg/m <sup>3</sup>
TPH-Diesel (TLV)	$\frac{100 \text{ mg/m}^3 \times 10^6 \text{ mg/kg}}{8,500 \text{ mg/kg}}$	=	11,764 mg/m <sup>3</sup>

<sup>5</sup> Office of Environmental Health Hazard Assessment (OEHHA) Chronic REL based on 2,3,7,8-tetrachlorodibenzo-p-dioxin

## **Programmatic Health and Safety Plan**

### *Topock Final Groundwater Remedy Phase 1/ Phase 2 Construction Project*

---

Of the 10 COCs listed above, chromium VI had the lowest minimum dust concentration (0.93 mg/kg) to reach the exposure limit threshold and thus the minimum total dust level for chromium VI will be set as the total dust action limit for construction work within the AOCs. Work in dust levels above 0.93 mg/m<sup>3</sup> (based on 15-minute average airborne concentration) will require additional PPE protection beyond Level D.

All PHSP will need to include COCs from specific AOCs where work will be performed.

## **7.5 AIR MONITORING**

### **7.5.1 Action Levels**

The general airborne AL's set for this project are listed in Table 7-3. Air monitoring for this project is to be performed as per this PrHSP and contractors PHSP. Specific contaminants monitored during the project will be particulates (total dust), combustibles including methane (LEL), oxygen, carbon monoxide (CO), hydrogen sulfide and Volatile Organic Compounds (VOC)s, where applicable. The following ALs are based on currently available soil, water data or referenced in Cal/OSHA regulations. Air monitoring is required when it is reasonable to believe that there may be an excursion above the AL or PEL. Furthermore, the use of direct reading instruments is required to provide real time information and the basis for further air testing, upgrading or downgrading PPE use. Actual monitoring for certain COCs will be determined and presented in PHSP or JSAs.

## Programmatic Health and Safety Plan

### Topock Final Groundwater Remedy Phase 1/ Phase 2 Construction Project

Table 7-3: General Airborne Action Levels

DESIGNATED ACTION LEVEL CRITERIA			
Contaminant	Method or Instrument	Action Level <i>All readings to be collected within operators breathing zone (OBZ)</i>	Actions Taken
TPH-Diesel as Total Volatile Organic Compounds (VOC) Non-methane  (Within impacted AOC)	Photoionization Detector (PID) A suitable lamp e.g., 9.8, 10.6, or 11.7 eV will be selected based on the ionization potential of the specific COC	> 50 ppm 15-minutes average	Upgrade to appropriate respiratory protection; Start conformational sampling for using colorimetric detector tubes (e.g., dräger) if other VOCs suspected. Stop Work in AOC, if action level (AL) cannot be reduced implement engineering controls and respiratory protection will be required.
Total Dust based on Cr VI (Within AOCs)	Real-time Particulate Monitor (personal DataRAM™ (PDR)-1000)	> 0.93 mg/m <sup>3</sup> 15-minutes average	Implement engineering controls including but not limited to additional dust suppression "adequate wetting"; Upgrade PPE as necessary
Particulates not Otherwise Regulated (PNOR)  Total Dust (Outside AOCs)	Real-time Particulate Monitor (PDR-1000)	> 5 mg/m <sup>3</sup> 8-hr TWA	Implement engineering controls including but not limited to additional dust suppression "adequate wetting"; Upgrade PPE as necessary
	NIOSH 0500	> 10 mg/m <sup>3</sup> 8-hr TWA	<b>Stop Work, determine source of hazard and apply engineering control, Upgrade PPE as necessary</b>
PNOR  Respirable Dust	Real-time Particulate Monitor w/ impactor (DustTrak or equivalent)	> 2.5 mg/m <sup>3</sup> 8-hour TWA	Implement engineering controls including but not limited to additional dust suppression "adequate wetting"; Upgrade PPE as necessary
	NIOSH 0600	> 5 mg/m <sup>3</sup> 8-hr TWA	<b>Stop Work, determine source of hazard and apply engineering control, Upgrade PPE as necessary</b>
Silica (respirable fraction)	NIOSH 7500	> 25 µg/m <sup>3</sup> 8-hr TWA	Implement engineering controls including but not limited to additional dust suppression "adequate wetting"; Upgrade PPE as necessary
		> 50 µg/m <sup>3</sup> 8-hr TWA	<b>Stop Work, determine source of hazard and apply engineering control, Upgrade PPE as necessary</b>
Asbestos	NIOSH 7400/7402	> 0.1 f/cc Cal/OSHA PEL 8-hr TWA  > 1 f/cc Cal/OSHA Excursion Limit 30-min average	If suspect ACM is discovered during site activities, work will <b>immediately stop</b> , area cordoned off, PCM, PG&E, and external agencies, as required, will be notified, and the suspect material tested.

**Programmatic Health and Safety Plan**

*Topock Final Groundwater Remedy Phase 1/ Phase 2 Construction Project*

<b>DESIGNATED ACTION LEVEL CRITERIA</b>			
<b>Contaminant</b>	<b>Method or Instrument</b>	<b>Action Level <i>All readings to be collected within operators breathing zone (OBZ)</i></b>	<b>Actions Taken</b>
Combustible Gas (CG)	4-Gas Meter (MutiRae or Equivalent)	> 10% LEL	The field team will discontinue activities during those periods of time when meter readings in ambient air exceed the AL and further test, eliminate source of vapor until levels can be brought to ±1%.
Lower Explosive Limit (LEL) Methane		Any detection above background drift or fluctuation - Prior to hot work near flammables or if gas leak is suspected	Identify source of vapors and ventilate until readings indicate source has been controlled.
Hydrogen Sulfide (H2S)	4-Gas Meter (MutiRae or Equivalent)	> 5 ppm	Raise awareness and continue monitoring to confirm level
		> 10 ppm	Leave area and upgrade to appropriate respiratory protection
Carbon Monoxide (CO)	4-Gas Meter (MutiRae or Equivalent)	> 25 ppm	Leave area and identify source of carbon monoxide. Eliminate source or provide engineering controls if feasible, upgrade level of PPE and continue to closely monitor airborne concentrations.

## 7.5.2 Equipment

The following typical equipment will be used by the contractor and subcontractor SSO, where appropriate:

- 4-Gas Meter (O<sub>2</sub>, CO, H<sub>2</sub>S and LEL) with a Photo ionization detector (PID) (9.8, 10.6 or 11.7 eV lamp depending on ionization potential);
- Particulate/Dust monitor (PDR-1000 or equivalent);
- Colorimetric detector tubes e.g., Dräger for specific chemicals deemed necessary by the contractors SSO; and,
- Personal sampling pumps, tubing, and cassettes/collection media in accordance with OSHA and NIOSH requirements for worker monitoring, where necessary.

The contractors and subcontractors SSO shall ensure that all necessary monitoring equipment, in sufficient numbers, are available prior to work initiation. Other equipment deemed necessary by the SSO prior to work initiation shall be obtained at his/her direction.

The contractor and subcontractor SSO shall also ensure that these instruments are used only by persons who have had prior experience with their care, calibration, and operation and who know equipment limitations. Equipment will be pre- and post-calibrated, and bump tested daily. For example, a typical 4-Gas Meter with PID should be zeroed out with zero air. Span calibration gas for PID – 25 or 100 ppm Isobutylene; H<sub>2</sub>S – 10 ppm; CO – 25 or 50 ppm; Methane – 2.5% (50% LEL); and 18% O<sub>2</sub>. Calibration records will be kept detailing the date, time, calibration gas and concentration used, and name of person performing calibration, see section 7.5. All calibration and maintenance will follow the manufacturer's guidelines.

## **7.6 COMBUSTIBLE/EXPLOSIVE GASES AND OXYGEN DEFICIENT/ENRICHED ATMOSPHERES**

A combustible gas meter (MutiRae 4-gas meter or equivalent) will be used to monitor the work environment for combustible gases, potentially explosive atmospheres, and oxygen deficient or enriched atmospheres. The field team will discontinue activities during those periods of time when meter readings in ambient air are:

- Equal to or greater than 10 percent of the LEL
- The oxygen concentration is less than or equal to 19.5 percent
- The oxygen concentration is greater than or equal to 23.5 percent.

## **7.7 DOCUMENTATION**

Strict adherence to document and data control procedures is essential for quality assurance. Data and calibration records must be accounted for and be retrievable at all

## **Programmatic Health and Safety Plan**

### *Topock Final Groundwater Remedy Phase 1/ Phase 2 Construction Project*

---

times. Types of documents that are essential include notes, logbooks, maps, data sheets, equipment-calibration logs, and reports; all of which must be placed in the project files. Copies of all field data reports, and personal sampling records will be sent to the CHSM for review, initially weekly, and following review will collect monthly.

The contractor SSO will ensure that all data are documented in logs or logbooks including the following:

- Calibration data
- Types of calibration materials used
- The manufacturer and model number of instruments used
- The date and time of calibration and monitoring events
- The area or personnel monitored
- The atmospheric conditions and weather
- Unique site conditions if any
- Equipment operating in area
- Any other information that affects the data or the actions taken based on the data
- The individual(s) performing the monitoring will initial all logbook entries.

## **8.0 VEHICLE SAFETY**

Vehicle safety applies to all field personnel, contractors, subcontractors, and visitors operating motor vehicles on the Site. Only those individuals trained in safe operation and authorized by the employer may operate such equipment. Seat belts shall be provided and worn on all equipment where rollover protection is installed, and employees shall be instructed in their use. (CCR, Title 8, §3653 and, §1596). Reference PG&Es Code of Safe Practices Section 3 in Appendix I. As per PG&E's Journey Management directive contractors must include a Journey Management and Trip Risk Assessment Checklist within their PHSP, see attached in Appendix W.

### **8.1.1 Authorized Drivers**

- Must have a current driver's license for the appropriate class of vehicle (unless more stringent requirements are established by the leasing/renting agency).
- Non-employees (e.g., contractors, subcontractors, visitors) may not operate PG&E owned, leased, or rented vehicles.

### **8.1.2 General Operating Policy and Procedure**

- Authorized drivers required to operate vehicles with special hazards (i.e., trucks carrying fuel cells, vehicles used to tow trailers, vehicles with limited visibility, etc.) shall be thoroughly briefed on the hazards and control measures necessary for safe operation of the vehicle.
- Drivers/operators shall know and obey all federal, state, and local motor vehicle laws applicable to the operation of their vehicle. All vehicles entering the Site shall have up to date licenses, records, and documentation within the vehicle and all vehicles will comply with applicable Department of Transportation (DOT) requirements.
- All cargo extending 4 feet or more beyond the end of a truck, trailer or similar vehicle shall be clearly marked with a red warning flag or cloth measuring no less than 16 inches' square. Red lights must be used at night.
- Seat belts and shoulder harnesses (occupant restraint systems) shall be worn or used whenever the vehicle is in operation. The vehicle may not move until all passengers have fastened their restraints.
- When parking or leaving a vehicle, the following procedures must be followed: engage the transmission in park (automatic transmission) or first gear (standard transmission), shut off the engine, set the parking brake, remove the ignition keys, and lock the vehicle.
- The vehicle's engine is to be turned off during refueling. Smoking or cell phone use is not allowed while refueling.
- Drivers/operators will not drive or operate vehicles while under the influence of alcohol or illegal drugs.



- Drivers/operators will not drive or operate vehicles while under the influence of medications when told by a physician, another healthcare provider, or the manufacturer (i.e., instructions on the label) that the activity is unsafe.
- Driver/operators may not deactivate or muffle any backup warning device.
- For diesel-fueled vehicles at any location within the state of California, do not idle the vehicle's primary diesel engine for more than five consecutive minutes. (PG&E Utility Standard ENV-1003S) Construction contractors shall also ensure that all nonessential idling of construction equipment is restricted to five minutes or less in compliance with California Air Resources Board's Rule 2449 (MMRP, AIR-1). Construction equipment shall not idle for extended periods of time (more than 15 minutes) when not being utilized during construction activities. A notable exception is when a support vehicle is needed to remain running for health and safety reasons (i.e., air conditioning), consistent with health and safety procedures (MMRP, NOISE-2).

### 8.1.3 Field Site Vehicle Safety

- When applicable, define specific vehicle travel routes and parking areas at field sites. Use fencing, cones, or other markings to define roads and parking.
- When performing fieldwork requiring the blocking of traffic lanes (e.g., bridge inspection or general traffic control), follow applicable Traffic Control Plan (TCP, to be provided by project Compliance team), county and state encroachment permits, the Manual on Uniform Traffic Control Devices for Streets and Highways (American National Standard Institute (ANSI) D6.1) and local police requirements for barriers, cones, and flaggers. (CCR, Title 8, §1598 - §1599).
- Articles, tools, equipment, etc. placed in vehicles shall be stored as not to interfere with vision or the proper operation of the vehicle in any way. This also includes preventing items from flying about or out of the vehicle during sudden stops, turning, etc.
- Trucks or vehicles with obstructed rear-view mirrors must observe the following procedures when backing up: position an employee to act as a spotter at the rear of the vehicles, in the driver's line of sight, to ensure that the area behind the truck is clear. If no other employee is present, then the driver must step out of the vehicle and check the area behind the vehicle before backing up. As an added precaution, avoid backing up whenever possible.
- No use of cell phone is allowed while operating a vehicle or equipment. Contractor partners are prohibited from using hands-free phones, including Bluetooth® Devices (Smart Watch, etc.) or other wired earpieces while driving on PG&E Business. See Appendix V for more information.
- Drivers should complete a 360° walk-around of the vehicle to visually inspect the condition of tires and look for possible obstructions or wildlife that may be in the path of travel.

- Drivers of vehicles 10,001 lbs. GVWR and greater must always use wheel chock blocks in addition to setting the appropriate parking system to secure the vehicle. For single-axle vehicles 10,001 lbs. GVWR and greater, a minimum of two-wheel chocks are required. (PG&E Safety Advisory – Wheel Chock Requirements, 2023)
- Vehicles may only travel on unpaved roadways or surfaces that have been approved within the applicable Environmental Release to Construction (ERTC); vehicle speed limit on unpaved roads is 10 miles per hour (MPH), unless posted otherwise, to limit generation of dust; measures, such as wetting of surfaces, will be employed to prevent dust generation by vehicular traffic or other dust-generating work activities. (MMRP, Table 1, 2018).

#### 8.1.4 Off-Road Vehicle Safety

To protect site personnel operating all-terrain vehicles (ATV) and utility task or utility terrain vehicles (UTV), riders must comply with the following:

- Contractors are required to follow the operating guidelines and requirements of PG&E TRAN-2053S and TRAN-2053P prior to the use of Class 1 and Class 2 All/Utility-Terrain Vehicles (ATV/UTV), including expanded training, safety controls and safety mechanisms. The term “Class 1” refers to both ATV/UTV and recreational off-highway vehicles grouped together due to similar manufacturer specifications and PPE requirements. The term “Class 2” refers to low speed golf cart style units designed for operation off the highway and have a maximum speed of 25 mph.
- As described in TRAN-2053S/P, Contractor shall not use Class 1 ATV/UTV’s without PG&E’s written approval. The Contractor’s request for approval, or Business Case, shall include a description of the specific make/model the ATV/UTV, the rationale for the need to use an ATV/UTV (as opposed to other alternatives), and the training program for each operator. Documentation of operator training shall be uploaded to ISNetworld. An approved Business Case is not required to operate Class 2 UTVs. All Class 2 UTVs may be used if training was completed before first use.
- Required minimum PPE, a hard hat, safety glasses, and any other PPE in the operator’s manual, must be worn during use.

Reference Appendix Q for PG&E’s guidance on ATV/UTV usage.

## 9.0 PERSONAL PROTECTIVE EQUIPMENT

When engineering controls, administrative controls, or work practice controls, are not feasible to protect employees from hazards, employers will provide the PPE necessary to protect employees from hazards. The PPE described in this section for the indicated protection levels meets ANSI standards or equivalent. Only personnel who have been certified by a physician as physically capable of respirator usage will be allowed to work at Levels A, B, and C.

Expected PPE levels for this project are summarized herein. Protection may be upgraded or downgraded, as appropriate, only after the contractor SSO has consulted with the project team and/or a Certified Industrial Hygienist (CIH). Required level of protection for specific tasks will be included in contractor and subcontractor’s approved JSAs. If respiratory irritation or breathing discomfort is experienced at any time, respirators will be donned immediately. If irritation or discomfort continues, personnel will be escorted from the work area and the project team will be notified.

**Each employer will be responsible for providing necessary PPE to its own employees. All personnel working on the project must arrive on-site with their individual assigned PPE, as required for the project. Additionally, contractors and subcontractors working within an AOC with potential chemical hazards, where necessary, will have Level C PPE available on-site, as described below.**

The individual SSOs for each employer will be responsible for ensuring that all personnel comply with the PPE requirements outlined in this section. SSOs may refer to <https://www.osha.gov/laws-regs/regulations/standardnumber/1926/1926.65AppB>

Table 9-1 provides a quick selection guide on what type of PPE is to be worn within specific work areas. See section 9.1 for requirements for each PPE item.

*Table 9-1: Quick Selection Guide for Minimum Required PPE*

Minimum Level of Personal Protective Equipment (PPE)	Work Area		
	Construction Areas Outside TCS	Non-Construction Areas Outside TCS	Inside TCS
<b>Level D</b>	X	X	X
Short sleeves (no sleeveless or tank top)	X	X	
Long Pants	X	X	X
Long sleeves			X
Fire resistant (FR) clothing (HRC-2 single layer daily wear, Arc Rating 8 cal/cm <sup>2</sup> )			X
Gloves (If appropriate and/or as specified in JHA/JSA for work task)	X	X	X
Hard hat (minimum standard must meet ANSI Z89.1 Type 1, Class C, G & E Standards)	X		X
Safety glasses (ANSI Z87+)	X	X	X
ANSI Class II or III high visibility vest or shirt (vest required inside TCS)	X	X	X
Boots (Steel or Composite toe)	X	X	X
<i>Job may require additional protection stipulated in JSA; upgrade of PPE will be required.</i>			

## **9.1 REQUIREMENTS**

### **9.1.1 Eye Protection/Safety Glasses**

Impact resistant safety glasses, which are approved by the American National Standard Institute (ANSI) Z87+, shall be worn as necessary to protect against flying particulates or projections at all times at the Site. (CCR, Title 8, §3382)

### **9.1.2 Hand Protection/Gloves**

Hand protection suited for the safe performance of one's job shall be worn to protect against injury. (CCR, Title 8, §3384)

### **9.1.3 Head Protection/Hard Hats**

ANSI-approved hard hats (minimum standard must meet ANSI Z89.1 Type 1, Class C, G & E Standards) shall be worn at all times at the Site during the Project related activities. (CCR, Title 8, §3381)

### **9.1.4 Foot Protection/Steel Toed Shoes**

During all phases of work, boots or shoes having steel or composite reinforced toe, and shank (where applicable), shall be worn to protect against falling objects and crushing or penetrating actions. Work boots should cover and secure the ankle to provide support and additional protection. Other types of foot protection may be required for work in wet locations. (CCR, Title 8, §3385, ANSI Z41 and American Society for Testing and Materials (ASTM) F-2413-2005)

### **9.1.5 Clothing**

Clothing shall be worn that is best suited for the safe performance of one's job. (CCR, Title 8 § 3383). All personnel working within Topock Compressor Station must wear Flame Resistant (FR) clothing (long sleeves and pants), Hazard Risk Category (HRC)-2 compliant (as defined by National Fire Protection Association (NFPA) 70E, 2012 having an arc rating that is greater than or equal to 8 cal/cm<sup>2</sup>. FR clothing is not required for personnel parking and attending meetings in the TCS conference room.

### **9.1.6 Fall Protection**

Fall protection shall be used when exposed to a fall in excess of 6-feet. (CCR, Title 8, §3299; Title 8, §1670;)

### **9.1.7 Respirator and Cartridges**

If Level C PPE is required, workers will don a NIOSH/Mine Safety and Health Administration (MSHA)-certified half-face air-purifying respirator (APR), full-face, or PAPR equipped with NIOSH/MSHA-approved cartridges. Warning: Improperly installed or incorrectly selected chemical cartridges will provide inadequate or no protection.

## Programmatic Health and Safety Plan

### Topock Final Groundwater Remedy Phase 1/ Phase 2 Construction Project

All cartridges will be changed using end of use or flow indicator depending on type. Water saturation of filters or dusty conditions may necessitate more frequent changes. More importantly, cartridges will also be changed if workers begin to experience increased inhalation resistance or chemical breakthrough. Respirators will be checked by the contractor's SSO prior to the beginning of site work and periodically thereafter. However, individual workers are responsible for inspecting their respirators before each use as well as cleaning and decontaminating them after each use. All respirators must be properly stored in their appropriate containers, when not in use.

Fit testing of all personnel that wear negative pressure air-purifying respirators will be conducted annually using qualitative (isoamyl acetate or irritant smoke) or quantitative (PortaCount) procedures. The fit test will be for the style and size of the respirator to be used. The fit test will be documented, and the results filed with the employee's personnel medical records. In addition, the respirator user will conduct an inspection of the respirator, and a positive and negative fit check every time a respirator is donned...

Respirators with tight-fitting facepieces will not be worn by employees who have facial hair that comes between the sealing surface of the facepiece and the face or that interferes with valve function; or any condition that interferes with the face-to-facepiece seal or valve function.

## 9.2 LEVEL D PPE

Level D represents the **minimum** level of personal protection required on site. It is used only as a work uniform and in areas where no respiratory or skin hazards are present. The work party in the support zone will use Level D PPE.

Table 9-2: Level D Required Equipment

<b>LEVEL D REQUIRED PERSONAL PROTECTIVE EQUIPMENT</b>	
<b>Work Within TCS</b>	<b>All other project work</b>
<ul style="list-style-type: none"><li>• Hard Hat</li><li>• Safety Glasses or Safety Goggles (ANSI Z87+)</li><li>• Long-sleeve shirt (<i>FR Clothing required as per Section 9.1.5</i>)</li><li>• Long pants or coveralls (<i>FR Clothing required as per Section 9.1.5</i>)</li><li>• Fluorescent traffic safety vest (minimum Class 2) (Shirts are prohibited in lieu of vests)</li><li>• Boots with toe protection</li></ul>	<ul style="list-style-type: none"><li>• Hard Hat</li><li>• Safety Glasses with side shields (ANSI Z87+)</li><li>• Short-sleeve shirt</li><li>• Long pants or cotton coveralls</li><li>• Fluorescent traffic safety vest or shirt (minimum Class 2)</li><li>• Work gloves, task specific if needed</li><li>• Boots with toe protection</li></ul>
<b>Modified Level D</b>	
<ul style="list-style-type: none"><li>• Work gloves, task specific if needed</li><li>• Face Shield</li><li>• Ear plugs</li><li>• Ear plugs</li><li>• Dust mask</li><li>• Disposable coveralls</li><li>• Disposable booties or rubber boots</li><li>• Nitrile gloves (worn beneath work gloves)</li></ul>	<ul style="list-style-type: none"><li>• Face Shield</li><li>• Ear plugs</li><li>• Dust mask</li><li>• Disposable coveralls</li><li>• Disposable booties or rubber boots</li><li>• Nitrile gloves (worn beneath work gloves)</li></ul>

### 9.3 LEVEL C PPE

Level C protection is used when air-purifying respirators are needed for respiratory protection and/or when a low level of skin protection is needed. If Level C protection is required, the PPE listed in the following table will be used but may be revised by the SSO based on the work activities being conducted.

Table 9-3: Level C Required Equipment

<b>LEVEL C REQUIRED PERSONAL PROTECTIVE EQUIPMENT</b>	
<b>Work Within TCS</b>	<b>All other project work</b>
<ul style="list-style-type: none"> <li>• Hard Hat</li> <li>• Safety Glasses or Safety Goggles (ANSI Z87+)</li> <li>• Long-sleeve shirt (<i>FR Clothing required as per Section 9.1.5</i>)</li> <li>• Long pants or coveralls (<i>FR Clothing required as per Section 9.1.5</i>)</li> <li>• Fluorescent traffic safety vest (minimum Class 2)</li> <li>• Work gloves, task specific if needed</li> <li>• Steel-toed boots with chemical-resistant soles</li> <li>• Face Shield, if needed</li> <li>• Ear plugs, if needed</li> <li>• spun-bonded, melt bound, spun-bonded (SMS) or Coated Tyvek</li> <li>• Disposable over boots (chemical protective, latex or polyvinyl chloride (PVC)) Work gloves</li> <li>• Other gloves (nitrile), If needed</li> <li>• Half-face or Full-face air-purifying respirator or Powered air-purifying respirator (PAPR) with approved cartridges (High Efficiency Particulate Absolute (HEPA), Organic Vapor, Acid Gas).</li> </ul>	<ul style="list-style-type: none"> <li>• Hard Hat</li> <li>• Safety Glasses with side shields (ANSI Z87+)</li> <li>• Short-sleeve shirt</li> <li>• Long pants or cotton coveralls</li> <li>• Fluorescent traffic safety vest or shirt (minimum Class 2)</li> <li>• Work gloves, task specific if needed</li> <li>• Steel-toed boots with chemical-resistant soles</li> <li>• Face Shield, if needed</li> <li>• Ear plugs, if needed</li> <li>• Disposable over boots (chemical protective, latex or PVC) Work gloves</li> <li>• Other gloves (nitrile), If needed</li> <li>• Half-face or Full-face air-purifying respirator or PAPR with approved cartridges. (HEPA, Organic Vapor, Acid Gas).</li> </ul>

### 9.4 LEVEL B PPE

Level B is used when supplied air is needed for respiratory protection and a higher level of skin protection is needed. Level B protection is not necessary for most projects and is not addressed in this PrHSP. If conditions warrant an upgrade to Level B PPE, an amendment to this PrHSP will be prepared and approved by PG&E or representative.

### 9.5 LEVEL A PPE

Level A protection is used when the highest levels of respiratory and skin protection are considered necessary. Like Level B, Level A protection is not necessary for most projects and is not addressed in this PrHSP. If conditions warrant an upgrade to Level A PPE, an amendment to this PrHSP will be prepared and approved by PG&E or representative.

### 9.6 RESPIRATORY PROTECTION UPGRADE GUIDELINES

In the event air quality monitoring mandates, the use of respiratory protection, work operations will be shut down and the following will occur before re-entering exclusion zone:



## Programmatic Health and Safety Plan

### Topock Final Groundwater Remedy Phase 1/ Phase 2 Construction Project

---

- Properly trained and medically qualified personnel, as directed by the contractor SSO, will inspect their respirators, clean them as necessary, ensure proper function, and don.
- Personnel shall perform both negative and positive pressure respirator fit tests. If a respirator failure is noticed, it shall be immediately reported to the contractor SSO, and the defective respirator will be repaired or replaced.
- In the event respirator repairs or replacement cannot be made, the affected employee shall be removed from the work area until such time as a properly functioning and fitting respirator has been acquired.
- Each employee shall ensure that his/her individual respirator is equipped with cartridges appropriate for the type(s) of contaminants described in Section 7.0. Common cartridge types are organic vapor, particulate, or combination organic vapor/acid gas/particulate cartridges. Project personnel and contractors are responsible for having replacement cartridges available on site.
- Work operations will resume once all personnel have donned respiratory and, if necessary, dermal protection and the contractor SSO is satisfied that all PPE is in place and properly functioning.
- Air quality monitoring will continue as described in contractors PHSP and Section 7.0, when necessary.
- If it is determined half-face respirators are not adequate for the vapor concentrations recorded, work shall cease, and the appropriate respiratory protection obtained and/or engineering controls implemented. The contractor SSO will ensure that only appropriately trained personnel who have been fit-tested with “upgraded” respiratory protective equipment will be utilized in continued operations.

Within certain limits, respirators protect workers from inhaling toxic contaminants. Various respirator systems provide different levels of protection. Protection factors (PF) for respiratory protection devices are presented in list below.

Table 9-4: Respirator Protection Factors

<b>RESPIRATOR PROTECTION FACTORS</b>	
<b><i>Respiratory Devices</i></b>	<b><i>*Protection Factor (PF)</i></b>
Air-purifying Respirator - Half-face	10x
Air-purifying Respirator - Full-face	50x
Powered Air-purifying Respirator (PAPR) - Full-Face	1000x
Supplied Air (Full-face Pressure Demand Airline)	1000x
Self-contained Breathing Apparatus (Pressure demand or Positive Pressure mode)	10,000x

\* OSHA-assigned PFs for each respirator device in 29 Code of Federal Regulations (CFR) 1910.134, CCR T8, 5144.



## Programmatic Health and Safety Plan

### Topock Final Groundwater Remedy Phase 1/ Phase 2 Construction Project

A PF is the ratio of the atmospheric contaminant concentration to that of the concentration inside the respirator face piece. PFs may be used to calculate the Maximum Use Limit (MUL) of a properly fit-tested respirator. Personnel and contractors are required to be equipped with properly fitted half-face and full-face respirators.

NIOSH Chemical Hazards Sheets are presented in Appendix R.

## 9.7 ADDITIONAL SAFETY EQUIPMENT

The additional safety equipment listed in Table 9-5 will be provided in locations as indicated below.

Table 9-5: Additional Safety Supplies and Equipment

Additional Safety Supplies and Equipment	All Work Zones	Construction Office	Heavy Equipment	On Person
Automated External Defibrillator	X	X		
Air Horns for emergency notification	X	X		
Chemical Spill Kit	X	X		
Fire Extinguisher (Type ABC)	X	X	X	
First Aid Kit including Blood Borne Pathogen (BBP) supplies	X	X		
Hand Wash and Towels	X	X		
Mobile Phone				X
Portable Eye Wash/Shower	X	X		
Radios for traffic control or remote access locations				X
Satellite Phone in limited mobile access locations, where needed				X
Sunscreen	X	X	X	
Traffic Cones, Delineators, and Barrier Tape	X	X		
Water or other Rehydration Fluid	X	X	X	
Wind direction indicator	X	X		

### 9.7.1 First Aid Kits

Each work site must have ANSI Z308.1 approved first-aid kits including BBP provisions that are protected from the weather, readily accessible at all times, regularly inspected, and restocked weekly, as necessary. First-aid kits must also be located in the field vehicles. In addition to field vehicles, each Prime contractor location also maintains first-aid kits. All first-aid kits will be inspected at minimum, on a monthly basis as described in Table 4-1. The PHSP must prescribe the specific locations of first-aid kits. CCR, Title 8, §1512

### 9.7.2 Automated External Defibrillator (AED)

An AED must be accessible within 3 minutes from injured person, protected by weather, regularly inspected, and available at all times. AED locations will be discussed in the Daily Tailgate Safety Meetings. All AEDs will be inspected at minimum, on a weekly basis as described in Table 4-1. The PHSP must prescribe the specific locations of AEDs.

### 9.7.3 Portable Eyewash Stations and Showers

Each work area must have a 16-ounce eyewash bottle that is readily available and easily accessible. Eyewash bottles offer a short-term, immediate rinse for personnel who get contamination in their eyes and are supplemental to portable eyewash stations. As required by Cal/OSHA, where an employee may come in contact with a substance which can cause corrosion, severe irritation or permanent tissue damage or which is toxic by adsorption, a portable eyewash and shower equipment must be provided. Eye wash and Shower must meet the requirements under ANSI Z358.1 Emergency Eye Wash and Shower Equipment, to provide 15 minutes continuous flushing and be accessible within 10 seconds away from injury. Once the eyewash bottle has been used, personnel should find a plumbed or temporary eyewash station or another device that meets ANSI Z358.1. Eyewash bottles should be stored protected from direct sunlight and high temperatures so that flushing water temperature is maintained at <100°F. During high heat conditions eyewash bottles may be stored in a cooler to keep liquid temperature between 60°F – 100°F.

Eyewash bottles must be located in designated field areas and inspected as indicated in Table 4-1. The PHSP must prescribe the specific locations of eyewash bottles. Eye wash stations and shower's locations will be identified, where required. (CCR, Title 8, §5162)

### 9.7.4 Fire Extinguishers

A minimum 10-pound fire extinguisher capable of extinguishing Class A, B, and C fires will be available for use at the site at all times. The contractors SSO will determine the actual number, size, and type of fire extinguishers. Project personnel will be readily aware of the location of the fire extinguisher and will be trained on when and how to use a fire extinguisher.

Each contractor will maintain a training log for their site personnel. On project sites where, electrical equipment and components may be vulnerable to corrosive, ABC extinguishing agents, extinguishers with non-corrosive agents, such as carbon dioxide, may be located near this equipment for use in emergencies. Fire extinguishers will also be located in each field vehicle. The PHSP must prescribe the specific locations of fire extinguishers.

## **10.0 DESIGNATED WORK AREAS**

Construction work for this project will be conducted in both non-contaminated soil areas and within AOCs. Construction work may also involve contact with contaminated groundwater. The site safety zones and procedures should match the prescribed levels of personal protection. The contractors SSO will establish, control, and monitor these designated work areas accordingly.

Pre-mobilization planning (performed prior to the Project, as required by the Project environmental impact report mitigation measures) will include a site review to determine where contaminated soil may be encountered, and to establish procedures for handling encountered soil. This site review, in addition with existing site soil investigation results will be used to delineate work areas as within or outside an AOC, as described in Sections 10.1 and 10.2. Work zone definitions will also be routinely evaluated during the course of the Project, and a work zone may be reclassified based on site conditions encountered during implementation.

### **10.1 WORK OUTSIDE OF AOCs AND NO GROUNDWATER CONTACT**

#### 10.1.1 Work Zone

Only authorized personnel may enter the work zone. Personnel must wear at a minimum Level D protection as defined in section 9.2.

#### 10.1.2 Observation Zone

Observation zones will be established to manage a safe distance for observers and visitors.

### **10.2 WORK WITHIN AOCs OR WORK WHERE GROUNDWATER CONTACT MAY OCCUR**

Soil data in the planned work areas will be used to determine the potential levels of exposure and a plan will be developed to protect workers and prevent the spread of contamination. The following methods will be used as appropriate:

Designated work areas within AOCs where there is potential exposure to soil or airborne dust or where groundwater contact may occur, will consist of exclusion zones, contamination reduction zones, and support zones as defined by the contractor SSO based on the tasks to be completed. Barrier tape and delineators (or similar) will be used to define the work zones. The use, size, and locations of the work areas will be dictated by the work activity, the presence of existing structures, and other site-specific restrictions. No eating, drinking, or smoking shall be allowed in the designated work areas. Work zone boundaries will be clearly identified and may be relocated, as appropriate, as the work progresses.

#### 10.2.1 Support Zone

The “support zone” is the area around or adjacent to the principal work area, in which the possibility of encountering hazardous materials is minimal. Therefore, upgraded personal

protective and respiratory equipment are not necessary. Inside the support zone, the following will be available:

- An effective means of communication
- First aid supplies
- Fire extinguisher – (location(s) to be provided in PHSP)
- Portable eye wash station/bottles and shower, where required
- Drinking water
- Sanitation facilities
- Wind indicator
- Other appropriate support facilities (such as shade structure, chairs, and tables)

### 10.2.2 Contamination Reduction Zone

The “contamination reduction zone” is the transition area between the contaminated area and the clean area. This is also the area where equipment and personnel are decontaminated after leaving the exclusion zone. Personnel will remove and decontaminate PPE and place it in the appropriate containers. Site vehicles and equipment will also be decontaminated in the contamination reduction zone. The contamination reduction zone will consist of a decontamination pad (temporary or permanent); a means of decontaminating protective equipment, site vehicles, and equipment; and containers for liquid, solids, and PPE.

### 10.2.3 Exclusion Zone

The “exclusion zone” includes the area where work activities will be conducted (e.g., drilling, excavation, sampling, etc.). Only authorized, trained, and qualified personnel with the appropriate PPE shall be admitted.

Work activities within the exclusion zone pose the greatest possibility of exposure to hazards. The SSO shall be responsible for controlling the access points and keeping bystanders and unauthorized personnel from entering. The exclusion zone will be clearly marked with flagging, barricade tape, traffic cones, or other access restriction devices.

## 10.3 CONTROLLED ACCESS ZONE

For all designated work areas, contractors and subcontractors may elect to establish a controlled access zone (CAZ) to prevent unauthorized entry and protection from physical hazards. Specifically, a CAZ will create a safe setback to control personnel from approaching potentially hazardous activities (for example rotating or moving mechanical equipment).

## **11.0 DECONTAMINATION PROCEDURES**

Decontamination procedures will be performed within the contamination reduction zone, upwind of contamination, where applicable. For unplanned decontamination procedures a temporary CRZ will be established according to the guidelines listed in sections 11.1 and 11.2. Appropriate receptacles for disposal of miscellaneous equipment, PPE, and decontamination water and soap will be provided. General decontamination procedures are presented below.

### **11.1 PERSONNEL**

The following procedures will be followed for decontaminating workers:

- Chemical-resistant gloves shall be worn when handling chemicals with skin notation and whenever possible.
- Personnel leaving the exclusion zone will wash, rinse, and remove gloves and wash hands and face in clean water using soap.
- If wearing Level C dermal and respiratory protection, prior to exiting the exclusion zone, personnel will wash, rinse, and remove gloves and boots. Remove Tyvek™ or equivalent and place in a properly labeled waste container. Wash whole body, hands and face in clean water using soap.
- Respirators will be cleaned and sanitized before and after each use.

### **11.2 EQUIPMENT**

The following procedures will be followed for decontaminating equipment:

- All tools and equipment to be removed from the site during or after work activities will be washed properly decontaminated using water and brush.
- Large heavy equipment to be removed from the work zone will be decontaminated, as necessary. Dry decontamination may be used as long as potential occupational exposures are controlled.

## **12.0 SANITATION FACILITIES AND DRINKING WATER**

Proper sanitation facilities will be available at the work site. These facilities will be located within the support zone and may include, but are not limited to:

- Potable Water (CCR T8, §1524)
- Washing facilities (CCR T8, §1527)
- Showers, if applicable (CCR T8, §1527(3))
- Toilets (CCR T8, §1526)

A minimum of one separate toilet facility shall be provided for each 20 employees or fraction thereof of each sex. A minimum of one separate washing station shall be provided for each 20 employees. Water and soap to wash hands and face will be available near the work area. Wastes from portable sanitary facilities will be removed at a minimum of once per week.

## **13.0 SITE SECURITY AND CONTROL**

This section addresses site security, normal work hours, and requirements pertaining to after hours and weekend operations. See Specification Section 00 72 00 for more details.

All contractor personnel will be required to wear ISN badges while on-site. All project visits will require mandatory check-in and check-out. Daily attendance will be captured via roster, or electronic attendance system. The Site CHQ is the primary location for check-in and check-out or may be captured in real time on a mobile device at another pre-determined location by the contractor, upon approval. Site visitors will also be required to check-in and check-out of the Site and follow other requirements as specified by PG&E. Contractors, monitors, and visitors that do not have ISNetworld badges, will be issued a temporary badge. Visitors must be accompanied by authorized personnel while on-site, and badges/passes will be worn at all times.

### **13.1 SITE SECURITY**

Site security procedures will be consistent with the Site Security Plan (CRAWP Appendix Q). The Site Security Plan includes, but is not limited to, protocols for regular inspections of the Project Area during working and non-working hours; ensuring construction zones and protective measures are being maintained; ensuring personnel use designated travel routes and parking areas; notification and reporting of outside disturbances to the environment; worker cultural resources sensitivity training; and visitor access controls (MMRP, Table 1, 2018).

Access to the Site work is limited to authorized personnel only. Security for remedial facilities located inside TCS will be provided by the existing PG&E security team. Remedial facilities outside of TCS will be equipped with security features consistent with PG&E's security standards. Specifically, the CHQ will be equipped with perimeter fencing, gates with chains and locks, security alarm system, lighting and cameras. Satellite staging areas used for construction equipment and materials may be fenced, locked and include cameras or alarms. Lighting for security will be temporary and in conformance with Table 1 of the MMRP. Construction contractors will establish and enforce separate security measures for safeguarding equipment, materials, and constructed facilities. Security guards equipped with vehicles, flashlights, and two-way radios will be roaming the Site providing inspections during working and non-working hours. Security services for the Project will be contracted by PG&E.

### **13.2 WORK HOURS**

Contractors will normally perform Work on-site between the hours of: 7:00 am to 3:30 pm, Monday through Friday, unless otherwise agreed to with PG&E. For any on-site work to be performed outside these hours, contractors will require approval in advance by the PG&E Site Operations Manager via the PCM. No more than ten (10) consecutive hours per day will be allowed to be performed on-site (including tailgate meetings and cleanup), unless otherwise agreed to with PG&E (Spec 00 72 00 C1).



### **13.3 AFTER HOURS/WEEKEND OPERATIONS**

Nighttime construction-related activities shall be limited to circumstances that require work in the nighttime periods because it cannot be disrupted or suspended (e.g., drilling or concrete pouring) or work may require an early morning start to ensure completion within 1 day or because of heat constraints including with regard to personnel health and safety (MMRP, Table 1, 2018). For any on-site work to be performed outside normal work hours or on weekends, contractor will require approval in advance by the PG&E SOM via the PCM.

## **14.0 TRAINING AND MEDICAL SURVEILLANCE REQUIREMENTS**

This section addresses training and medical surveillance requirements.

Information provided below constitutes the general minimum site-wide requirements for all personnel that require unaccompanied access to project work zones. Specific work zones will require additional training relative to the work being performed, for example, personnel entering a work zone where high voltage electrical hazards are present will require appropriate electrical safety training prior to entering that work zone. This PrHSP does not list all required training for all work involved during the Project. The PHSP for each scope of work or JSA will provide the detailed training requirements involved for that work and is to be used in conjunction with this PrHSP to identify training requirements for project personnel. See Appendix S for an example of Cal/OSHA required training.

This section assumes all personnel have already completed Worker Environmental Awareness Training (WEAT), TCS safety training (if needed) described in Sections 5.1 and 5.2 and PG&E required ISN trainings. Work zones themselves are described in detail in Section 10.0.

Documents verifying adequate H&S training will be maintained by the contractor SSO and submitted to PG&E and CHSM or designee prior to mobilization.

### **14.1 INITIAL TRAINING**

#### **14.1.1 HAZWOPER Training**

All field personnel handling any groundwater and any worker in an AOC where there is potential exposure to soil or airborne dust from earthwork will need to complete an initial 40-HAZWOPER training program and annual 8-hour refresher training in accordance with CCR, Title 8, §5192(e)(3)(A) & §5192(e)(8), respectively. Compliance monitors (Jacobs and subcontractors), other monitors (tribal, biological, archeological, & cultural), and visitors will need a minimum of initial 24-hour HAZWOPER training to perform monitoring or make observations within the exclusion zone, CCR, Title 8, §5192(e)(3)(B).

#### **14.1.2 Hazard Communication Program**

The purpose of a Hazard Communication or Employee Right-To-Know program is to ensure that potential chemical hazards are communicated to the potentially affected workers. The written hazard communication program shall include the following:

- *Container Labeling* – Site personnel will ensure that all drums and containers are labeled according to contents. All labels will be checked for identity, hazard warning, and name and address of the responsible party.
- *Hazardous/Toxicity Information or safety data sheet (SDS)* – There will be either a NIOSH Guide to Chemical Hazards onsite or PHSP will include an SDS for each hazardous chemical used or known to be on

site. Chemical inventory/storage locations must be included in each Contractor's PHSP.

- *Employee Information and Training* – Employees are trained on the general hazards of chemicals and the use of SDSs through formal annual training. Project-specific chemical hazards are communicated to workers through an initial site safety meeting and during the daily site safety meetings.

The contractors written hazard communication or employee right-to-know program will be available onsite. Workers are to be instructed on contractor's HazCom program with the following minimum content:

- Chemicals in the work area and their hazards.
- Ways to prevent exposure to hazardous chemicals.
- Company plans and procedures to prevent worker exposure to these chemicals.
- Procedures to follow if they are exposed to hazardous chemicals.
- How to read and interpret labels and SDSs for these chemicals.
- Emergency spill procedures and equipment.
- Proper storage, labeling, and disposal of hazardous chemicals.

#### 14.1.3 Site-Specific H&S Pre-Job Training

All field personnel will attend Project Safety Orientation prior to entering the site. All field personnel will be trained in the general and specific hazards unique to the project prior to starting work. All personnel will sign acknowledgement to document receipt of this one-time training. The following topics will be discussed:

- Personnel responsible for site safety
- Identification of first aid, cardiopulmonary resuscitation (CPR) and AED trained personnel (A minimum of one contractor supervisor and one worker must be trained on the project site)
- Health and safety hazards on-site
- Location, use, and care of PPE
- Location of all safety equipment
- Location of the PrHSP
- Site standard operating procedures and safe working practices
- Site work zones and confined space
- Areas of potential environmental contamination, associated hazards, and associated requirements

- Site control measures
- Air monitoring procedures, where required
- Emergency information and procedures

#### **14.2 DAILY SITE SAFETY TRAINING**

Site safety training meetings will be held prior to beginning work each day to discuss the potential hazards of work activities to be completed during the day and any special hazards associated with the project.

#### **14.3 MEDICAL SURVEILLANCE FOR HAZWOPER**

All personnel who will conduct work within Sites that are governed by HAZWOPER regulations will receive preliminary baseline medical screening and clearance from a licensed physician prior to start of work. Additionally, medical surveillance and physicals will be conducted, and clearance obtained by a licensed physician for all HAZWOPER personnel annually. Reference Cal/OSHA CCR, Title 8 §5192(f)(2).

#### **14.4 MEDICAL SURVEILLANCE FOR HEAT STRESS**

It is recommended that contractors institute a medical monitoring program for all workers who may be exposed to heat stress. A preplacement medical evaluation should follow section 1.2.2 presented on page 5 Recommendations for an Occupational Standard for Workers Exposed to Heat and Hot Environments, (U.S. Department of Health and Human Services, Centers for Disease Control and Prevention, National Institute for Occupational Safety and Health, Department of Health and Human Services (DHHS) (NIOSH) Publication No. 2016-106, see Appendix S).

#### **14.5 MEDICAL SURVEILLANCE FOR RESPIRATOR USAGE**

For workers who anticipate donning respirators, on an annual basis, a medical doctor will pass all site personnel as physically fit and capable of wearing respiratory protection, where required. Workers that cannot provide documentation in support of this requirement will not be permitted to work at the site on tasks requiring respiratory protection.

## 15.0 EMERGENCY RESPONSE AND EVACUATION PLAN

### 15.1 EMERGENCY TELEPHONE NUMBERS

Table 15-1: Emergency Contact List

Local Fire Station		(760) 326-0438 or <b>911</b>
Local Police Dept. – Needles County Sherriff		(760) 858-4864 or <b>911</b>
Phoenix Interagency Federal Law Enforcement		(800) 637-9152
Hospital, Colorado River Medical Center	1401 Bailey Ave., Needles, CA	(760) 326-7100 or <b>911</b>
Urgent Care Clinic, Valley View Medical Center	5330 AZ-95, Fort Mohave, Arizona 86426	(928) 788-2273
Poison Control Center (California)		(800) 222-1222
Chemical Transportation Emergency Center (CHEMTREC)		(800) 262-8200
On Highway – California Highway Patrol		911
Off-Highway – CA Office of Emergency Services		(800) 852-7550
Off-Highway – AZ Division of Emergency Management		(602) 244-0504
EPA Region IX Emergency Response Office		(415) 974-8132
National Response Center (all reportable spills)		(800) 424-8802
U.S. Coast Guard (spills to water)		(804) 441-3516
TOXLINE		(301) 496-1131
USA South		811
PSC (PG&E Emergency Spill Contractor)		(844) 334-2468
PG&E Topock Compressor Station		(760) 326-5535
PG&E Project Manager	John Glass	(628) 219-4369
PG&E Site Operation Manager	David Diaz	(760) 903-3013
PG&E ER Program Manager	Lauren Baeta	(925) 655-7002
PG&E Environmental Field Specialist	Valeri Hirst	(760) 577-4642
PMO Site Operations Manager - <i>Arcadis</i>	Janet Newman	(949) 293-2445
PMO Health and Safety Coordinator - <i>Arcadis</i>	Mary-Catherine Goddard	(415) 535-7458
Topock CM Principal in charge - <i>Arcadis</i>	Daniel Talbot	(315) 391-2528
Project Construction Manager - <i>Arcadis</i>	Matthew Stenstrom	(775) 447-0036
Construction Health and Safety Manager – <i>Advanced Environmental Group</i>	Matt Michaelian	(949) 322-8335

#### **Standard Procedures for Reporting Emergencies**

##### **In an *Emergency***

- From a desk phone, land line or cell phone, **CALL 911**

**If it is an injury or medical assistance is needed:**

- **If you are the injured person, notify your supervisor as soon as possible.**
- **At least one person, will stay with injured person and administer first aid/CPR/AED if trained to do so until emergency personnel arrive.**
- **Notify Project Construction Manager via telephone or radio. If no one answers contact, Construction Health and Safety Manager, PG&E Project Manager, and PG&E Site Operation Manager until an acknowledgement is received. Follow event reporting in Table 4-3: Event Reporting Guidance.**

## 15.2 NEAREST HOSPITAL AND CLINIC INFORMATION

### Nearest Hospital **Colorado River Medical Center**

Transportation to a medical facility for emergencies must be done by at least two individuals.

**18 min (14.0 miles) via I-40 W**  
**145453 National Trails Hwy**  
**Needles, CA 92363**

Head north on National Trails Hwy - 1.8 mi

Turn left onto Park Moabi Rd - 0.5 mi

Turn right to merge onto I-40 W - 10.7 mi

Take exit 142 for J St toward Downtown - 0.3 mi

Turn left onto J St - 0.5 mi

Turn left onto Bailey Ave - 0.2 mi

Destination will be on the left

**Colorado River Medical Center**  
**1401 Bailey Ave, Needles, CA 92363**

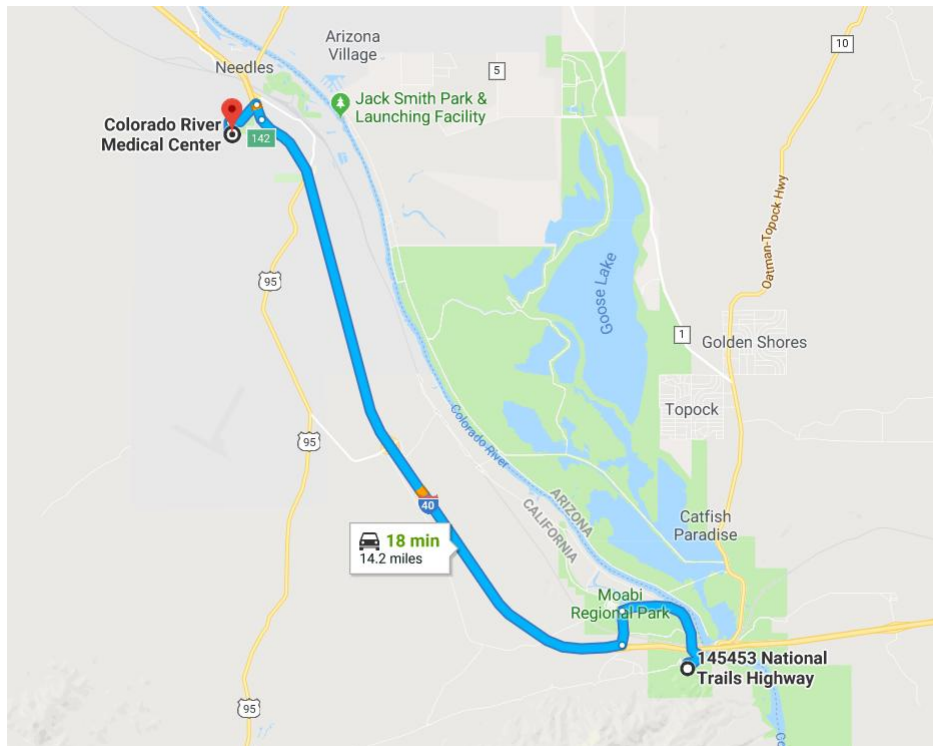

**Nearest Clinic**  
**Valley View Medical Center**

Transportation to this medical facility is for non-emergency occupational medical treatment, drug screening, and physicals.

**145453 National Trails Hwy  
Needles, CA 92363**

Head south on Park Moabi Rd toward National Old Trails Hwy – 0.5 mi  
Turn right to merge onto I-40 W – 0.2 mi  
*Follow I-40 W and Mohave Valley Hwy to Wagon Wheel Ln in Fort Mohave*  
Merge onto I-40 W – 10.5 mi  
Take Exit 142 for J St – 0.3 mi  
Turn right onto J St – 0.2 mi  
Turn left onto W Broadway St – 600 ft  
Turn right onto Needles Hwy – 0.6 mi  
Turn left onto N K St – 0.2 mi  
Continue onto Mohave Valley Hwy AZ-95 – 10.6 mi  
Turn right onto Wagon Wheel Ln – 436 ft  
Turn Left – 377 ft

**Destination will be on the right**

**Valley View Medical Center  
5330 AZ-95, Fort Mohave, AZ 86426**

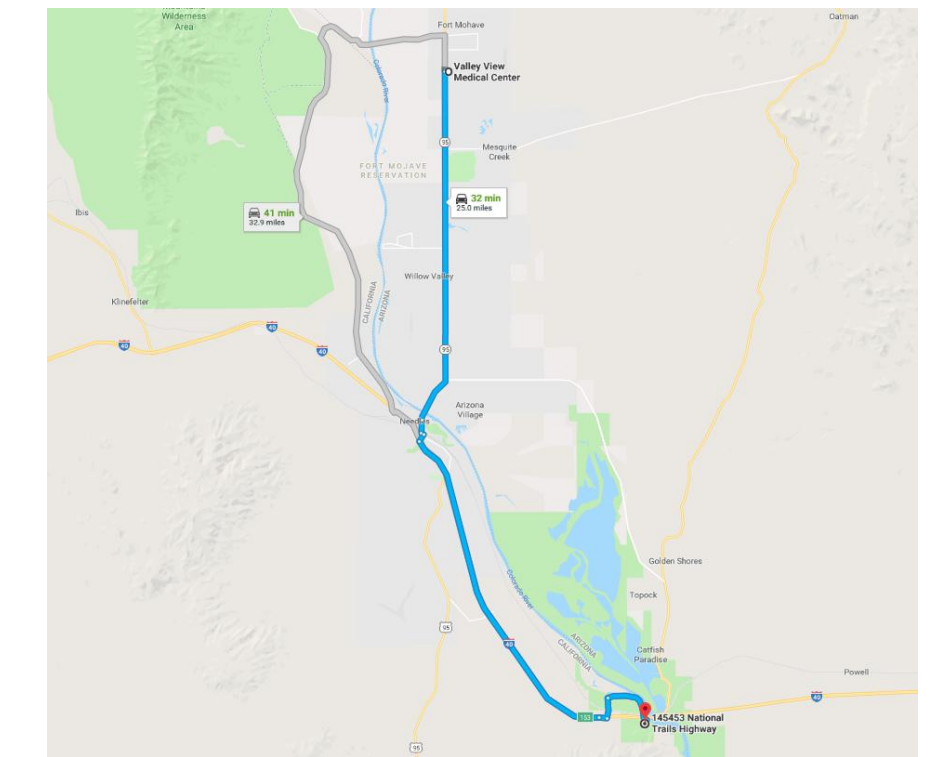



**Nearest Hospital – MW-X, Y'**  
**Colorado River Medical Center**

Transportation to a medical facility for emergencies must be done by at least two individuals.

**MW-X, MW-Y'**  
**Topock, AZ 86436**

Head Northwest toward Upper Levee Rd – 4.5 mi

Turn Left onto Upper Levee Rd – 4.3 mi

*Continue onto* Mohave Valley Dr, and Brackman Rd – 1.2 mi

Turn Left onto Levee Way – 0.6 mi

Turn left onto Harbor Ave/Mohave Valley Hwy – 0.5 mi

Continue straight onto N K St – 0.4 mi

Turn left onto Front St – 456 ft

Turn right onto J St – 0.3 mi

Continue straight to stay on J St – 0.5 mi

Turn left onto Bailey Ave – 0.2 mi

**Destination will be on the left**

**Colorado River Medical Center**  
**1401 Bailey Ave, Needles, CA 92363**

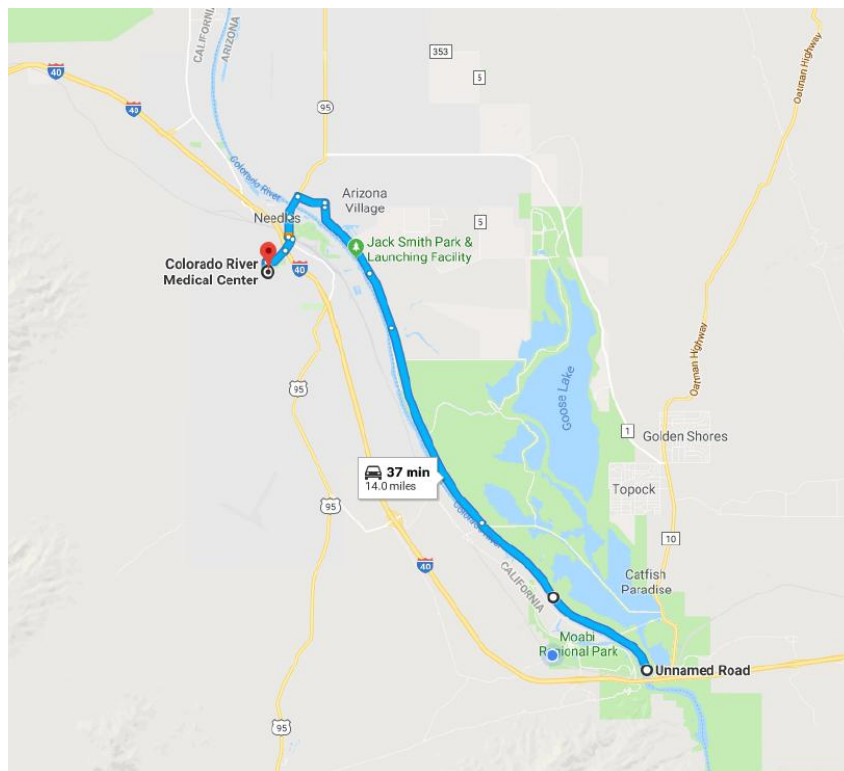

### **15.3 SITE EMERGENCIES AND EVACUATION ROUTE**

Potential site emergencies include, but are not limited to, natural disasters (e.g., fire, earthquake, severe weather) and other physical or chemical injuries that require immediate medical attention. All personnel will follow direction of the emergency evacuation plan, herein.

#### **15.3.1 Personnel roles, lines of authority and communication**

In the event of an emergency, contractor PM/SSO or designee will initiate any necessary notification of on-site personnel, site evacuation of the area, and/or notification of the appropriate emergency response authorities via 911 phone call, as needed. Contractor SSO must be notified and is responsible for responding immediately to any emergency. If an emergency situation requires an evacuation, the contractor PM/SSO or designee will use an air horn (three long blasts) to alert nearby personnel and will notify the PCM by phone or radio. The PCM will then alert any remaining impacted field personnel via an automated text messaging system or similar real time notification method. The PCM will take the lead during all emergency situations. In the absence of the PCM, the PG&E PM, PG&E SOM or CHSM will fill in as the lead. Project staff will rely on professional medical service providers for response to medical emergencies. The PCM will turn over the responsibility for coordination of an emergency to the appropriate responding emergency personnel, services, or agencies upon their arrival.

All on-site injuries, illnesses, and incidents will be managed by the contractor SSO with the assistance of project staff. Incident, near miss and first aid reports involving personnel will be filled out by the contractor SSO as per contractor Illness Injury Prevention Program (IIPP) and reported following project guidelines, see Table 4-3. All field personnel present at the site have the authority and responsibility to report a site emergency.

#### **15.3.2 Evacuation and Muster Point Locations**

Once notified of evacuation field personnel will leave the work area immediately by the shortest route possible and assemble at the predetermined muster point located upwind of, and at a safe distance from the work area. Ribbons or other visible wind direction indicators will be installed in the work areas to indicate current wind conditions. The location of the predetermined muster point(s) will be based upon the prevailing wind direction in the area. The location will be determined in advance of each work activity and will be identified to field personnel during the daily tailgate safety meeting. All assembly points will be at a safe distance from the emergency situation. In the event that refuge must be taken, the contractor SSO will direct personnel to a specific muster point location. A map showing the site muster points and emergency evacuation route is provided in Figure 4. The project muster points are listed below:

**Muster Location One (MP-1):** Outside of Construction Headquarters

**Muster Location Two (MP-2):** North End of project site, West of riverbank at turn out laydown area.

## **Programmatic Health and Safety Plan**

### *Topock Final Groundwater Remedy Phase 1/ Phase 2 Construction Project*

---

**Muster Location Three (MP-3):** North MW-20 Bench

**Muster Location Four (MP-4):** South MW-20 Bench

**Muster Location Four (MP-4A):** Top of C-14 Road adjacent to fence

**Muster Location Five (MP-5):** South End of project site, at Route 66 sign.

**Muster Location Six (MP-6) Topock Compressor Station:** TCS Parking lot area; Follow TCS emergency evacuation plan while working within station.

**Muster Location Six (MP-6A) Topock Compressor Station:** West side of TCS near office trailers; Follow TCS emergency evacuation plan while working within station.

**Muster Location Seven (MP-7)** Southwest of Bat Cave Wash adjacent to entry road.

**Muster Location Seven (MP-7A)** North of bat cave wash on Bench

**Muster Location Eight (MP-8) Settling Ponds:** At entrance of ponds at gate

#### ARIZONA DRILLING LOCATION – HYDRO-6

**Muster Location North (MP-A) North Location:** Located North of Hydro-6 near access road

**Muster Location South (MP-B) South Location:** Location South of Hydro-6 at entrance of access road

Alternate locations may be determined by the contractor SSO based on work activities, current weather conditions, and safe distance from the emergency.

#### ARIZONA DRILLING LOCATION - MW-X, Y'

**Muster Location North (MP-N) North Location:** Located North of MW-X near road

**Muster Location South (MP-S) South Location:** Location North of MW-Y' at West Shore

Once notified of evacuation, field personnel will leave the work area immediately by the shortest route possible and assemble at the predetermined muster point located upwind of, and at a safe distance from, the work area. Ribbons or other visible wind direction indicators will be installed in the work areas to indicate current wind conditions. The locations have been identified on Figure 5 and will be communicated to field personnel during the daily tailgate safety meeting. All assembly points will be at a safe distance from the emergency situation. In the event that refuge must be taken, the contractor SSO will direct personnel to a specific muster point location.

In the event that an emergency requires immediate evacuation from the peninsula, three pre-determined color-coded routes have been identified (See Figure 5). The Primary Northern evacuation route (red) will follow the main vehicular entry/egress to/from the work area. The secondary Northern evacuation route (blue) is an optional pedestrian only path. The primary Southern path (white) is a water evacuation route using a rescue skiff.

The rescue skiff, operated by Ground Water Partners, will be docked on the West shore (MP-S) during the active work hours to accommodate safe evacuation of affected workers and observers. The rescue skiff shall be equipped with all required safety items which include but are not limited to: life jackets, ring buoy, fire extinguisher, horn or sound producing device, and flares (see section 6.5.4 for details). The skiff operator will remain in the work area, immediately available to respond to an evacuation. If water evacuation is necessary, all affected personnel will don life vests prior to boarding skiff. The water evacuation procedures will be facilitated by a Ground Water Partners' Site Host. For all site personnel present at MW-X and MW-Y' locations, roles responsibilities and processes during a water evacuation will be clearly communicated and documented prior to the commencement of work. Additionally, a signed liability release will be required for all site personnel present. Water egress route will only be used for emergency evacuation situations.

Each contractor SSO will conduct a head count of evacuated field personnel to ensure that all are accounted for based on documentation recorded during daily sign-in and daily tailgates. The CHSM and PSSO(s) will verify that personnel have been accounted for at each muster point. The attendance system implemented will be used to confirm head counts of workers, visitors, and observers. Field personnel must not re-enter the work area until the PCM has determined that it is safe to do so.

When working in areas such as parking lots or between buildings, equipment and vehicles must be located to provide sufficient room for safe work practices and escape routes in case an emergency requires evacuation.

### **Topock Compressor Station**

The "Fire alarm" and the "Gas Detector alarm" are critical alarms project personnel working within the TCS need to be aware of. Other warning alarms go off at different times and are tied to different operator systems. There are light standards located throughout the station that indicate to the operator which area is generating the alarm. (Red—compressor building; Blue— aux building; White— oily water separator; Green— A Tower; Amber – B Tower). **"Gas Detector" alarm is an audible STUTTER Alarm and if activated all personnel working inside the compressor building must vacate compressor building and/or the aux bldg. until operations notifies safe to return.** There are blue strobes located inside and outside of the generator and compressor buildings that indicate dangerous levels of gas in the building. After the stutter has been acknowledged, these strobe lights will flash until it is safe to enter the building. For all emergency responses and evacuations within TCS, existing procedures will be followed. TCS Assembly Point Map is presented in Appendix U. Muster points 6 and 6A coincide with existing TCS assembly points.

### **15.4 PRE-EMERGENCY PLANNING**

Emergency contacts, telephone numbers, and the hospital route will be available on-site. Plans for a safe and effective response to potential emergencies will be developed by the contractor PM/SSO before daily field activities begin. Pre-emergency planning includes

reviewing the emergency response plan with site personnel and inspection of emergency response equipment and supplies. All existing emergency evacuation procedures will be followed.

### **15.5 SITE RESOURCES / EMERGENCY EQUIPMENT**

The locations of site resources and emergency equipment including but not limited to AED, first aid kits, etc. will be discussed at the site safety orientation meeting prior to commencement of site work. See list of Emergency Equipment in Table 9-4.

### **15.6 EMERGENCY HAND SIGNALS**

If an emergency situation occurs, all work activities at the site will cease. All personnel will follow the emergency evacuation plan in Section 15.0. All decisions to initiate evacuation will be managed by the PCM. If verbal communication is difficult, impractical, or impossible, the following hand/body emergency communication signals will be used:

*Table 15-2: Emergency Hand Signals*

<b>Signal</b>	<b>Meaning</b>
Hands clutching throat	Can't breathe/choking
Hands on top of head	Need assistance
Thumbs up	OK/I'm all right/I understand
Grip another person's wrist or both hands on another person's wrist	Leave area immediately

### **15.7 EMERGENCY SITE SECURITY AND CONTROL**

In the event of an emergency, security will control access and traffic to the work zones. If outside emergency services, such as the fire department, police, or paramedics, have been summoned, the PCM will turn over responsibility for the emergency situation upon their arrival.

### **15.8 CONTINGENCY PROCEDURES**

Life-threatening incidents, such as fire, explosion, or a hazardous material spill or release, may warrant evacuation. All persons should be removed from the affected area immediately in accordance with the site emergency evacuation route, see section 15.9. Medical assistance should be obtained if necessary. All on-site personnel should immediately be notified of the emergency situation as stated in section 15.0.

#### **15.8.1 Fire**

In the event of an explosion or fire, including wildfires, the affected area will immediately be evacuated and to closest muster point, if safe to do so, and the fire department summoned as soon as possible. All site personnel will be alerted of the fire and evacuation. Follow evacuation procedures set forth in Section 15.0. Upon arrival, the Fire

Department will be advised of the location and nature of the fire and the location and identification of hazardous and flammable materials on-site. At that point, the PCM will turn over responsibility for coordination to the Fire Department.

If it is safe to do so, site personnel may perform the following:

- Use available on-site fire extinguisher to control or extinguish the fire if it is a small, localized fire.
- Remove or isolate flammable or other hazardous materials that may contribute to the fire.

### 15.8.2 Material Spills

Field personnel are authorized to contain small incidental releases of hazardous material including contaminated groundwater by taking appropriate actions, such as immediate diking and cleanup, if the spill is created by project field activities. The equipment and all work areas will be maintained in a clean, proper working order. Caution will be exercised at all times to prevent spilling materials generated during field activities. In the event that project generated materials are spilled, response actions must be initiated by first contacting the Environmental Representative and following reporting guidance in section 4.4.1. Proper PPE and spill cleanup materials will be available on-site.

Hazardous material spills will be contained by immediate diking the impacted area and using spill cleanup materials present on site. Containment of spills by field personnel during field activities is limited to those materials generated during work performed by project personnel.

Project personnel are not authorized or trained for a hazardous materials response to contain spills or other materials on site. Field personnel are instructed to call the Environmental Representative and/or emergency response number if they witness any hazardous material spill other than materials generated during project activities or any release (Hazardous or Non-hazardous) to storm drain. Voice contact must be made, no messages to be left.

### 15.8.3 Earthquake

Any personnel inside a building during an earthquake should remain indoors and take cover under a desk, in a doorway, or against an inside wall. Personnel should stay away from windows and light fixtures. If outdoors, personnel should move to an open, clear area away from buildings, tanks, heavy equipment, aboveground piping, and power lines.

### 15.8.4 Severe Weather

#### Flash Flood

Leave work area and find higher ground if rapidly changing weather, rapid formation of clouds, drop in temperature is observed, or thunder is heard in the distance. If a flash



## **Programmatic Health and Safety Plan**

### *Topock Final Groundwater Remedy Phase 1/ Phase 2 Construction Project*

---

flood warning is issued, climb to higher ground. Seek shelter on stable ground. Do not stay in an area where there is un-compacted material on a steep slope.

Do not drive or walk into flood waters. Never drive around the barriers blocking a flooded road. A mere 6 inches of fast-moving flood water can knock over an adult. It takes just 12 inches of rushing water to carry away most cars and just 2 feet of rushing water can carry away trucks.

#### Electrical Storms

Outdoor operations will be suspended when lightning is within a 10-mile radius of project work areas or in the absence of lightning strike monitoring software, a 30 second time difference between seeing a lightning strike and hearing the sound. High profile equipment operations which include crane operations, drilling operations, or electrical wiring tasks shall be immediately suspended. Equipment operators shall safely stop and return equipment to a safe operating condition before heading for shelter. No personnel will be left on the ground in an exposed location. Preferred shelter is a permanent building. Personnel may also take shelter in trailers or low-profile rubber-tired equipment (e.g., pickups). Avoid driving pickups or any other equipment except to help evacuate personnel. Work will resume after a 30-minute period from last lightning strike.

- Seek shelter at the support facility or in field vehicles.
- Do not stand near or under high objects, such as trees and drilling rigs.

#### High Winds

Contractors must suspend work activities where wind conditions (at any speed) create an unsafe working condition for their employees and/or other site workers.

- Seek shelter at the support facility (if anchored) or in field vehicles.
- Do not drive high profile vehicles at high speeds.
- Park vehicles heading into the wind.
- Wear respiratory protection and safety goggles in dusty conditions, where needed, if working outside.

#### Heavy Rain or Hail

- Seek shelter at the support facility or in field vehicles.
- Do not attempt to drive a vehicle if you are in an area that is or has the potential for flooding.

#### Tornados

- Seek shelter underground or in a closet, bathroom, or interior of a substantial building. Get under something sturdy and cover your head.
- Do not stay in a trailer vehicle. Leave the trailer or vehicle and lie flat in the nearest ditch if substantial shelter is not available.
- Stay away from large areas of glass.



- Stay away from large unsupported roofs.

#### 15.8.5 Vehicle Accidents

Steps should be taken to avoid accidents:

- Be aware of the existence of pedestrian and vehicle traffic.
- Vehicle operators and passengers should wear seat belts/shoulder harness at all times.
- Follow local vehicle codes and stay within posted and safe speed limits.
- Drive and park vehicles only on roadways that can be negotiated safely.
- Drive company vehicles professionally and care for them as you would other company property. Only drive vehicles that are safe and within maintenance specifications.
- Practice defensive driving.
- Lock vehicles to prevent theft.
- To minimize the risk of injury, pedestrians should walk on the left-hand side of roadways, opposing vehicle traffic.
- Pedestrians should maintain awareness of all vehicular traffic.
- Pedestrians should not stand or walk near backhoe buckets or other earth moving equipment.
- Pedestrians should avoid areas where heavy equipment is operating.
- If vehicle won't start, stalls or gets a flat, illuminate emergency flashers, pull off to a safe location, place warning device behind vehicle with reflective side facing oncoming traffic, get to a safe area and call supervisor.

Minor accidents or "near misses," will be reported to the contractor SSO so that the circumstances can be investigated, and a repeat avoided. Contractor SSO will see that the Incident Report is filled out as per contractor's IIPP and reported as per project guidance. In the event of a serious accident or an accident involving two moving vehicles, the contractor SSO shall be notified immediately, and outside emergency services summoned as necessary. A serious accident or an accident involving two moving vehicles will also be reported in accordance with local law enforcement and Department of Motor Vehicle regulations. All near misses and incidents will be handled in accordance with Contractors' Incident Reporting form and project guidance, See Table 4-2.

#### 15.8.6 Workplace Violence

Steps should be taken to avoid workplace violence:

## **Programmatic Health and Safety Plan**

### *Topock Final Groundwater Remedy Phase 1/ Phase 2 Construction Project*

---

- Avoid individuals or situations that may lead to workplace violence. Don't aggravate, argue with, or confront someone who you believe is unstable.
- Report any such individuals or situations to your supervisor and/or security personnel.
- Report any unauthorized personnel, suspicious activities, or unauthorized vehicles to your supervisor and/or security personnel.
- If an active shooter is encountered on-site, the following response actions are to be taken as per the Department of Homeland Security recommendation:
  - Get Out - Evacuate area immediately if safe to do so
  - Hide Out – Hide in area out of sight of shooter's view and block entry to your hiding place. Silence cell phone.
  - Take Out – as a last resort and only when your life is in imminent danger, attempt to incapacitate shooter.
  - At any time during response, when safe, contact 911.

#### **15.8.7 Biological Bites and Stings**

Information on biological hazards and controls are provided in Appendix O. In the event of a venomous snake, spider, scorpion sting or bite, workers should take the following steps:

- Seek medical attention as soon as possible (dial 911 or call local Emergency Medical Services). Anti-venom rotates between 4 of the local hospitals, notify EMS of snake bite so anti-venom is procured immediately.
- Try to remember the color and shape of the snake, which can help with treatment of the snake bite. Contact Biologist monitor to help identify species of reptile or insect.
- Keep still and calm. This can slow down the spread of venom. Inform your supervisor.
  - Apply first aid if you cannot get to the hospital right away.
  - Lay or sit down with the bite below the level of the heart.
  - Wash the bite with soap and water.
  - Cover the bite with a clean, dry dressing.

#### **15.9 EMERGENCY DECONTAMINATION PROCEDURES**

In the event of chemical exposure requiring decontamination, personnel should remove contaminated clothing, rinse skin with large amounts of water, and seek medical attention.

## **15.10 PERSONAL INJURY**

### **15.10.1 Heat Illness**

Prior to assigning a crew to a worksite, ensure that a qualified and appropriately trained and equipped person is available at the site to render heat stress related first aid, if necessary. Respective PHSP or JSA shall name the trained first aid provider to provide immediate first aid.

Ensure that effective communication is maintained on the jobsite so that if needed, emergency services can be summoned quickly and efficient. All employees should monitor each other for signs and symptoms of heat illness. If an individual is showing signs of the beginning stages of heat illness, remove him/her from the direct sunlight and initiate cool down procedures. If an individual is showing signs of severe heat illness (such as, but not limited to decreased consciousness, staggering, vomiting, disorientation, irrational behavior, or convulsions) all work will be stopped, cool down procedures will be initiated, and if necessary, emergency medical services will be summoned.

### **15.10.2 Electrocutation**

In the event equipment or personnel contacts an overhead or underground power line, field personnel shall not touch the equipment or person in contact with the current and shall keep others away. If possible, equipment (such as excavators) operator should slowly move equipment away from overhead powerline to stop equipment from becoming energized from powerline. If movement of equipment is not possible, operator should remain in equipment and not contact conductive surfaces until the utility has been confirmed de-energized. Immediately call 911 and report event as per Table 4-2.

### **15.10.3 Emergency Medical Treatment and First Aid**

In the event of personal injury or illness, professional medical assistance should be summoned as appropriate.

First aid will be used to stabilize workers needing assistance will be given only by qualified personnel trained in first aid. Life support techniques such as CPR and treatment of life-threatening problems such as bleeding, airway blockage, and shock will be rendered immediately. Professional medical assistance will be obtained at the earliest possible opportunity. First aid equipment and supplies will be accessible at all times. Professional ambulance services will be used to provide prompt medical attention and transportation.

In the event of the following injuries:

*Chemical Inhalation* - If warning symptoms such as dizziness, headache, nausea, shortness of breath, burning in the mouth, or other symptoms indicative of the exposure are experienced, the victim will leave or be removed from the controlled area of the site immediately. If the victim is no longer breathing, rescuers will first remove the victim from the contaminated area wearing respiratory protection. Rescue breathing or cardiopulmonary resuscitation (as applicable) will be undertaken immediately, and medical attention will be obtained as soon as possible.

## **Programmatic Health and Safety Plan**

*Topock Final Groundwater Remedy Phase 1/ Phase 2 Construction Project*

---

*Chemical Ingestion* - Medical attention will be sought immediately

*Chemical Eye Contact* - If eye contact is made with any of the materials at the site, the eye will be flooded with water for at least 15 minutes. An emergency eyewash will be available in each work zone, either at the CRZ (at AOC work areas) or at the support zone at non-AOC sites, where required. Medical attention will be obtained as soon as possible.

*Chemical Skin Contact* - Skin exposure will be treated by washing with soap and water. Any contaminated clothing will be removed. First aid will then be applied, and medical attention obtained as required.

## FIGURES



Figure 1.  
Topock Ground Water Remedy Phase 1/2A  
Programmatic Health and Safety Plan  
Overview of Project Site



- Legend**
- Carbon Amendment Building
  - Constructions Head Quarters
  - Hydro-6 Well Location AZ
  - IM-3
  - Lay Down Yard
  - MW-20 Bench
  - MW-X Well Location AZ
  - MW-Y' Well Location AZ
  - Soil Processing Yard
  - Staging Area 9
  - Topock Compressor Station





Figure 2.  
Topock Groundwater Remedy Project  
AOCs and Planned Construction Areas

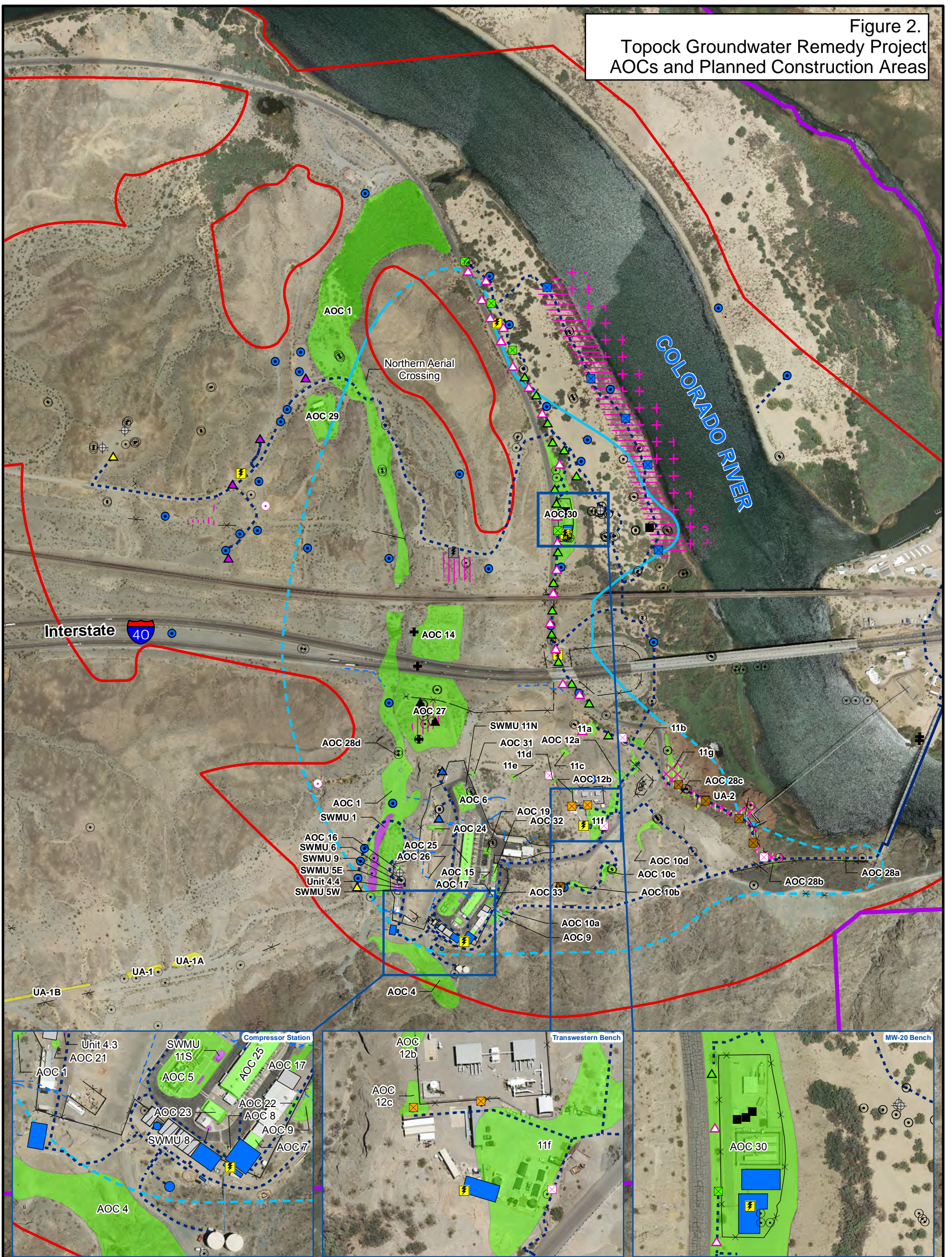

**LEGEND**

- |   |   |                                      |
|---|---|--------------------------------------|
| <b>Existing Wells:</b>                            | <b>Planned Wells:</b>   | — Site Fence Boundary                |
| ■ Extraction Well                                 | ■ Extraction, East Ravine   | --- Stormwater Piping Below Ground   |
| ⊕ Injection Well                                  | ■ Extraction, National Trails Highway (NTH) In-situ Reactive Zone (IRZ) | — Stormwater Piping Above Ground     |
| ○ Monitoring Well                                 | ■ Extraction, Riverbank   | <b>Pipeline Corridor for Remedy</b>  |
| ⊕ Water Supply Well                               | ■ Extraction, Transwestern Bench  | — Aboveground Pipe                   |
| <b>Provisional Wells:</b>                         | ▲ Injection, Freshwater   | --- Underground Pipe/Conduit         |
| ⊕ Extraction Well                                 | ▲ Injection, Inner Recirculation Loop                                   | ■ Area of Potential Effects (APE)    |
| ⊕ Injection Well                                  | ▲ Injection, NTH IRZ  | ■ EIR Project Area                   |
| ○ Monitoring Well                                 | ▲ Injection, Topock Compressor Station                                  | <b>Work Areas</b>                    |
| ⊕ Area for East Ravine (ER) Wells (ER-7 to ER-11) | ▲ Recirculation Well  | ■ Solid Waste Management Unit (SWMU) |
| ⊕ Area for Potential Slant Well Screens           | ▲ Area for Monitoring Well MW-T   | ■ Area of Concern (AOC)              |
| ⊕ Area for Inner Recirculation Loop (IRL) Wells   | <b>Transformers</b>   | ■ Other                              |
| ⊕ Area for River Bank                             | ⚡ Planned Transformer   | <b>Remedy Facilities</b>             |
| ⊕ Extraction Wells                                | ⚡ Future Provisional Transformer  | ■ Proposed Remedy Structure          |
|   |   | ■ Contingent Freshwater              |
|   |   | ■ Pre-injection Treatment System     |

Approximate extent of hexavalent chromium [Cr(VI)] concentrations exceeding 32 micrograms per liter (µg/L) at any depth in groundwater based on fourth quarter 2013 sampling events. Dashed where based on limited data.

- Notes:**
- All wells and remedy structure locations are approximate.
  - AOC 13 consists of the current and former unpaved areas within the fence line. AOC 18 consists of the hazardous waste transference pipelines and cooling tower blowdown pipelines.

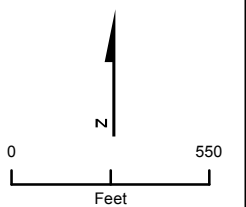

**FIGURE 1.0-1  
GROUNDWATER REMEDY FEATURES, SOLID WASTE  
MANAGEMENT UNITS, AND AREAS OF CONCERN  
GROUNDWATER REMEDY IMPLEMENTATION -  
SOIL MANAGEMENT PLAN  
PG&E TOPOCK COMPRESSOR STATION,  
NEEDLES, CALIFORNIA**



Figure 3.  
Topock Groundwater Remedy Phase 2  
Organizational Chart

**DRAFT**

**Legend**

- PG&E/Client
- Construction Manager
- DOR/Quality Assurance
- Compliance
- 3<sup>rd</sup> Party QA
- PMO
- H&S
- Arch/Bio/Visitor Mgmt
- Phase 2 Ops Manager
- Site Mgr/Well Const Supt
- Full-time onsite staff

- Line of Client Communication and Direction
- Line of team communication
- Line Contractual Reporting and Direction

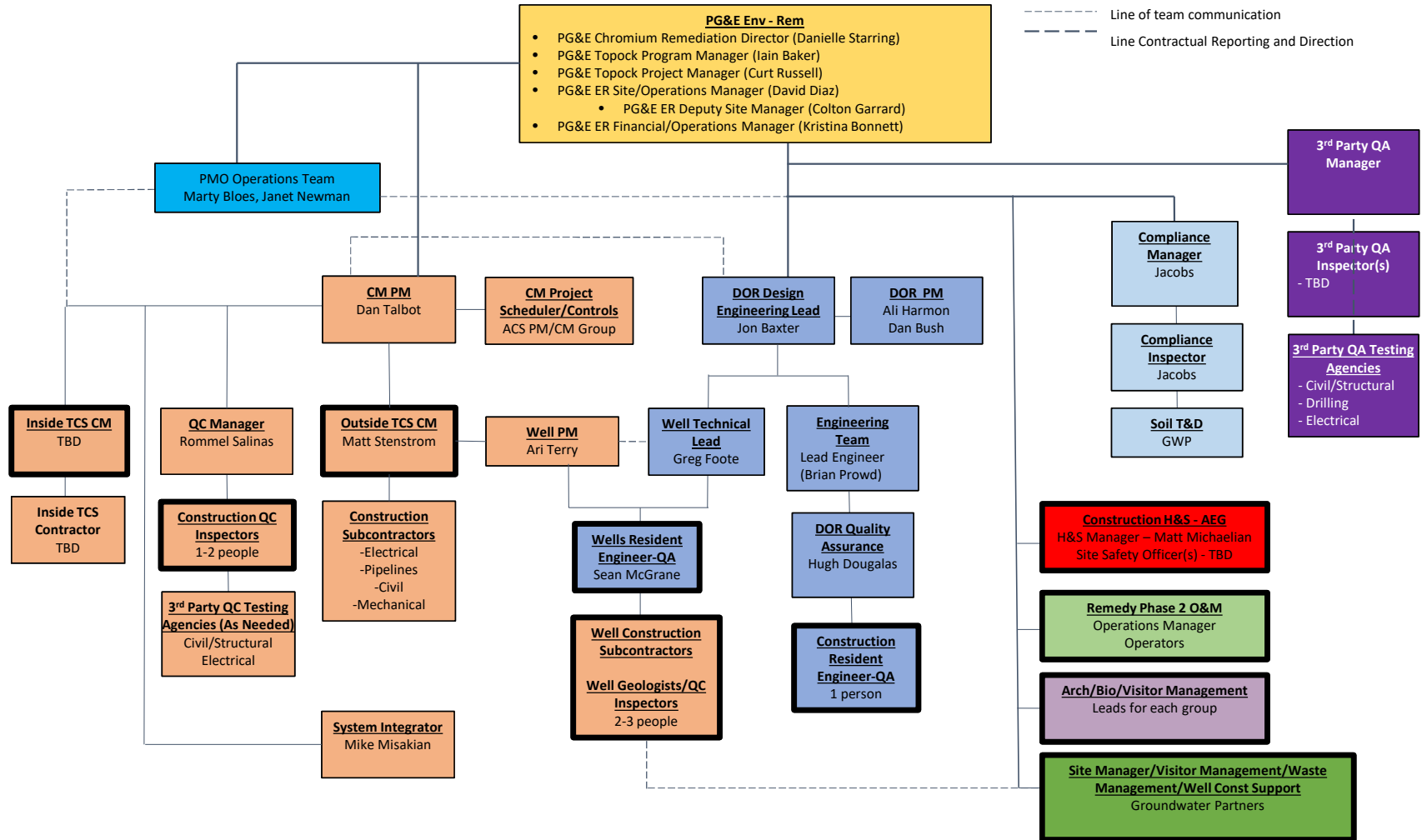



Figure 4.  
 Topock Groundwater Remedy Phase 1/2A  
 Programmatic Health and Safety Plan  
 Overview of Emergency Evacuation Muster Points



- Legend**
- Carbon Amendment Building
  - Construction Head Quarters
  - IM-3
  - Lay Down Yard
  - MW-20 Bench
  - Soil Processing Yard
  - Staging Area 9
  - Topock Compressor Station



Figure 5.  
 Topock Groundwater Remedy Phase 1  
 Programmatic Health and Safety Plan  
 Overview of Emergency Evacuation  
 Muster Points  
 Arizona Well Locations



**Legend**

- Hydro-6
- IM-3
- Muster Point
- MW-20 Bench
- MW-X
- MW-Y'
- SA-9
- VMC

2000 ft

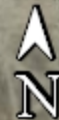



## **APPENDIX A**

### **PrHSP Training Roster**

**TOPOCK REMEDY PROJECT  
PROGRAMMATIC  
HEALTH AND SAFETY PLAN COMPLIANCE AGREEMENT**

Date	Name (Print)	Signature	Company



Advanced Environmental Group, Inc.  
8 Goodyear Suite 125, CA 92618 // (949)361-7797



## **APPENDIX B**

### **PG&E PHSP Checklist**



# Health and Safety Plan Review Checklist

Project Name: \_\_\_\_\_

Project Location: \_\_\_\_\_

PG&E Project Manager: \_\_\_\_\_

Contractor Name: \_\_\_\_\_

Contractor Project Mgr: \_\_\_\_\_

Reviewer: \_\_\_\_\_ Date: \_\_\_\_\_

Explanation	REVIEW COMMENT NUMBER	REQUIRED Y/N OR NA	ADDRESSED Y/N OR NA	ADDEQUATE DETAIL Y/N OR NA
<ul style="list-style-type: none"> <li>• Y/N = yes/no</li> <li>• NA = not applicable</li> <li>• A <i>required</i> with a 'Y', and an Addressed with a 'N' requires action</li> <li>* see comments (#) for details</li> </ul>				
<b>1. INTRODUCTION</b>				
<b>2. KEY PERSONNEL &amp; ASSIGNMENT OF SAFETY RESPONSIBILITY</b>				
2.1 Project Manager				
2.2 Project Safety Manager				
2.3 Site Safety Officer				
<b>3. SITE DESCRIPTION AND BACKGROUND</b>				
3.1 Site Description				
3.2 Site Background (History)				
<b>4. WORK OBJECTIVES</b>				
<b>5. JOB HAZARD ANALYSIS</b>				
5.1 Potential Chemical Hazards				
5.1.1 Health Hazards				
5.1.2 Physical Hazards				
5.2 Air Monitoring				
5.2.1 Personal				
5.2.2 Direct Reading Instruments				
5.2.3 Area Air Monitoring				
5.3 Biological Hazards				
5.4 Potential Physical Hazards				
5.4.1 General				
5.4.2 Head Injuries				
5.4.3 Foot Injuries				
5.4.4 Eye Injuries				
5.4.5 Hand Injuries				
5.4.6 Noise Injuries				
5.4.7 Overhead and Underground Utilities				
5.4.7.1 USA				
5.4.8 Miscellaneous Physical Hazards				

Explanation <ul style="list-style-type: none"> <li>• Y/N = yes/no</li> <li>• NA = not applicable</li> <li>• A <i>required</i> with a 'Y', and an Addressed with a 'N' requires action</li> <li>* see comments (#) for details</li> </ul>		REQUIRED	ADDRESSED	ADDEQUATE DETAIL
		Y/N or NA	Y/N or NA	Y/N or NA
<b>5. JOB HAZARD ANALYSIS</b> (continued)				
5.5 Environmental Hazards				
5.5.1 Noise				
5.5.2 Radiation				
5.5.3 Heat				
5.5.4 Light				
5.5.5 Cold				
5.5.6 Open Water				
5.6 Required Personal Protective Equipment				
5.6.1 Levels of Protection, Levels A,B C, D				
5.6.2 Site-Specific Levels of Protection by Tasks				
5.6.3 Provisions for Upgrade and/or Downgrade of Personal Protective Equipment				
<b>6. MEDICAL SURVEILLANCE PROGRAM</b>				
6.1 General				
6.2 Health Status Requirements				
6.3 Occupational Physician				
<b>7. TRAINING &amp; RECORD-KEEPING REQUIREMENTS</b>				
7.1 Hazardous Waste Operations & Emergency Response				
7.2 Site Specific Training				
7.3 Medical Surveillance				
<b>8. GENERAL SAFE WORK PRACTICES</b>				
8.1 Contaminant Ingestion				
8.2 Sanitation				
8.2.1 Drinking Water				
8.2.2 Hands and Face Washing				
8.2.3 Toilets				
8.3 Safety Briefings				
8.4 Required Safety Equipment				
8.5 Fire Extinguishers				
8.6 Personnel Communications				
8.7 Safety Labelings & Signs				
8.8 Contaminated Equipment				
8.9 Preventing Contaminant Dispersal				
8.10 Direct Contaminant Contact				
8.11 Heat Stress Control				
8.12 Site Engineering Control Measures				
8.13 Electrical Safety - Grounding of Equipment				
8.14 Trenching and Excavation				
8.15 Confined Space Entry				

Explanation <ul style="list-style-type: none"> <li>• Y/N = yes/no</li> <li>• NA = not applicable</li> <li>• A <i>required</i> with a 'Y', and an Addressed with a 'N' requires action</li> <li>* see comments (#) for details</li> </ul>		REQUIRED	ADDRESSED	ADDEQUATE DETAIL
		Y/N or NA	Y/N or NA	Y/N or NA
<b>8. GENERAL SAFE WORK PRACTICES</b> (continued)				
8.16 Cold Stress				
8.17 Traffic Control				
8.18 Heavy Equipment/Forklift Operations				
8.19 SDS Onsite				
<b>9. SITE CONTROL WORK AREAS &amp; DECONTAMINATION PROCEDURES</b>				
9.1 General Site Entry Requirements				
9.2 Field Operations Work Zones				
9.3 Decontamination Procedures				
9.3.1 Personal Decontamination				
9.3.2 Equipment Decontamination				
<b>10. EMERGENCY RESPONSE PLAN</b>				
10.1 Emergency Conditions				
10.2 Emergency Procedures				
10.2.1 General Requirements				
10.2.2 Accidental Release of a Gas				
10.2.3 Chemical Spill or Release				
10.2.4 Fires				
10.2.5 Explosion				
10.2.6 Personal Injuries				
10.2.7 Medical Emergency				
10.2.8 Earthquakes/Tsunami				
10.3 Site Emergency Warning Systems				
10.4 Emergency Communications and Notification Protocol				
10.4.1 Telephone Location				
10.4.2 Emergency Phone Numbers				
10.4.3 Emergency Call Protocol				
10.5 Accident Reporting Requirements				
10.6 Incident Reporting Requirements				
10.6.1 Agency Contacts				
10.6.2 PG&E EFS				
10.7 Emergency Decontamination Plan				
<b>11. PUBLIC SAFETY</b>				
11.1 Truck Safety Inspections				
11.2 Site Access Control				
11.3 Site Security				
11.4 Work Area Delineation				
11.5 Diesel Idling Controlled				
11.6 USA - Current Ticket				





# Health and Safety Plan Review Checklist

Project Name: \_\_\_\_\_

Project Location: \_\_\_\_\_

## REVIEW COMMENTS:

1.

2.

3.

4.

5.

6.

7.

8.

9.

## **APPENDIX C**

### **PG&E Bridging Documents**

**Form 2 – Enterprise Contractor Programmatic Safety Plan**

**Form 2 – Enterprise Contractor Programmatic Safety Plan**



## Enterprise Contractor Programmatic Safety Plan

<b>PG&amp;E PROJECT</b>			
<b>CONTRACTOR</b>			
<b>LOCATION</b>		<b>DOCUMENT DATE:</b>	
<b>CONTRACT/CWA #:</b>		<b>ESTIMATED START DATE:</b>	

**INSTRUCTIONS:** PG&E contractor project manager, safety representative, requestor etc. will complete this form and provide PG&E with a written safety plan using this attached *Programmatic Safety Plan* Form that will document how the contractor and subcontractor, at any tier, will address any anticipated and/or recognized hazards associated with their program/contract work.

This plan is an important step in the communication process to promote open communication between the contractor / subcontractors and PG&E on health and safety expectations and related issues and/or concerns. Detailed plans such as environmental protection, oil management, lift plan, spill mitigation etc. should be attached to this form separately, if applicable. This form along with its attachments, when completed, must be submitted to and approved by PG&E before starting work.



## Form 2 – Enterprise Contractor Programmatic Safety Plan

### 1.0 GENERAL INFORMATION

Detailed Program Scope Summary (Be as specific as possible):

**Risk Level of Work**

Medium  High

## Form 2 – Enterprise Contractor Programmatic Safety Plan

		Name(s)	Email	Contact #
PG&E Contacts	Program Lead			
	Work Supervisor			
	Safety Representative			
Contractor Contacts	Safety Plan Author			
	Program Lead			

### 1.1 FIELD LEADERSHIP AND SAFETY OVERSIGHT PLAN

Clearly identify the person(s) responsible for overseeing employees and subcontractors, including a plan for conducting observations and safety meetings:

### 1.2 GENERAL PERSONAL PROTECTIVE EQUIPMENT (PPE) REQUIREMENTS

Contractors are required to provide and ensure that workers use Personal Protective Equipment (PPE) as required by Cal/OSHA (California Code of Regulations [CCR], Title 8, Section 3380) regulatory requirements to perform their work activities safely and when defined in their safety plan, hazard analysis or when required to access a specific PG&E location.

Minimum Personal Protective Equipment required on a jobsite (as required and pertinent to the scope of work):

- Hard hat is rated for the scope of work and conditions. American National Standards Institute or (ANSI Z89)
- Safety glasses with side shields. American National Standards Institute or (ANSI Z87)
- Class 2 or 3 high visibility traffic vest or retroreflective fabric shirt (Arc Rated if appropriate for scope of work)
- Long sleeve shirts and long pants (flame resistant as required & pertinent to scope of work)
- Appropriate footwear. Standard Specification for Performance Requirements for Protective Footwear or (ATSM F2413)
- Gloves (as required & pertinent to task)



## Form 2 – Enterprise Contractor Programmatic Safety Plan

- Hearing protection (as required at or above 85 Db)
- COVID-19 face protection (Flame resistant as required & pertinent to task)
- Any additional PPE as required by your company's IIPP, PG&E contract, or pertinent industry regulations not covered in the above bullets.

Additional PPE requirements must be evaluated when performing specific tasks and must be identified in Section 2 of this document.

### 2.0 RISK ASSESSMENT AND HAZARD IDENTIFICATION

**HAZARD IDENTIFICATION:** Utilize the hazardous energy wheel below to identify energy that can kill you so you may define the hazard controls needed to effectively mitigate those hazards. The hazards encountered as part of this scope could include, but are not limited to:

## Form 2 – Enterprise Contractor Programmatic Safety Plan

<p><b><u>GENERAL HAZARDS</u></b></p> <ul style="list-style-type: none"> <li>• Uneven Ground/ Slips/ Trips &amp; Falls</li> <li>• Confined Spaces</li> <li>• Driving</li> <li>• Power Tool / Equipment Use</li> <li>• Ergonomics</li> <li>• Loading / Off-loading Equipment and Material</li> <li>• Unstable Ground Conditions / Slopes / Uneven terrain</li> <li>• Safety-At-Heights / Scaffolding / Ladders</li> <li>• Cave-ins/ Excavating / Trenching / Shoring</li> <li>• Suspended Loads</li> <li>• Welding / Oxy Acetylene / Grinding</li> <li>• Hot work</li> <li>• Aggressive Animals / Dogs / Etc.</li> <li>• High Crime Areas</li> <li>• Access</li> <li>• No Cell Service</li> <li>• Night Operations</li> <li>• Wildfire Safety</li> <li>• Dropped Objects</li> </ul> <p><b><u>HEALTH HAZARDS</u></b></p> <ul style="list-style-type: none"> <li>• Chemical Exposure / Burns</li> <li>• Noise Exposure</li> <li>• Pesticides / Fumigation</li> <li>• PCB / Lead / Mercury</li> <li>• Asbestos</li> <li>• Other Soil Contaminants</li> <li>• Hazardous Material Transportation</li> <li>• Hazardous Waste Transportation</li> <li>• Radioactive Exposure</li> </ul>	<p><b><u>PUBLIC SAFETY</u></b></p> <ul style="list-style-type: none"> <li>• Distracted, Impaired, Unsafe Motorists</li> <li>• Vehicular Traffic (Work Area Protection)</li> <li>• Pedestrian Traffic</li> <li>• Proximity to Railroads</li> <li>• Neighboring Facilities/Homeowner Issues</li> </ul> <p><b><u>EXCAVATION</u></b></p> <ul style="list-style-type: none"> <li>• Access / Proximity to Energized Equipment</li> <li>• Proximity to Energized Circuits</li> <li>• OH/UG Energized Lines</li> <li>• Overhead Objects</li> <li>• Appropriate Tools &amp; Equipment</li> <li>• Equipment Certifications</li> <li>• Blasting Safety / Certification</li> <li>• Confined Space</li> <li>• Open Excavation / Fall Restraint</li> <li>• Soil Type / Conditions / Shoring / Sloping</li> <li>• Slopes / Terrain</li> <li>• Spoil Management</li> <li>• USAs</li> </ul> <p><b><u>GAS HAZARDS</u></b></p> <ul style="list-style-type: none"> <li>• Oxygen Deficient Atmosphere</li> <li>• Explosive Atmosphere - Burns / Explosions</li> <li>• Clearance Procedures / LOTO</li> <li>• Dig-Ins / Line Strikes</li> <li>• Unmarked or Mismarked Utilities</li> </ul>	<p><b><u>CRANE</u></b></p> <ul style="list-style-type: none"> <li>• Crane Capacity</li> <li>• Crane Size</li> <li>• Load Weight</li> <li>• Lift Plans</li> <li>• Traffic / Transport</li> <li>• Setup/Access</li> <li>• Stability / Terrain</li> <li>• Rigging</li> <li>• Cribbing</li> <li>• Dangerous Operations</li> <li>• Equipment Certification</li> <li>• Operational Certification</li> <li>• Electrical Hazards</li> <li>• Equipment Grounding</li> <li>• Clearance</li> <li>• Environmental issues</li> <li>• Suspended Loads</li> <li>• Weather Conditions</li> </ul> <p><b><u>TRAFFIC CONTROL / FLAGGING</u></b></p> <ul style="list-style-type: none"> <li>• Environmental Conditions</li> <li>• Non-Compliant Drivers</li> <li>• Pedestrian Safety</li> <li>• Permits</li> <li>• Public Safety</li> <li>• Qualifications / Certifications</li> <li>• Site Specific Hazards</li> <li>• Traffic Control Plan</li> <li>• Low Light Conditions</li> <li>• Weather</li> <li>• Work Site Protection</li> </ul>	<p><b><u>ELECTRICAL HAZARDS</u></b></p> <ul style="list-style-type: none"> <li>• Clearance Procedures / LOTO / Grounding</li> <li>• Underground / Overhead Utilities</li> <li>• Proximity to Energized Equipment</li> <li>• Induction</li> <li>• Energized Work</li> </ul> <p><b><u>AVIATION</u></b></p> <ul style="list-style-type: none"> <li>• External Cargo</li> <li>• Landing Zone Safety</li> <li>• Rigging</li> <li>• Suspended Loads</li> <li>• Flying in a Wire Environment</li> </ul> <p><b><u>ENVIRONMENT HAZARDS</u></b></p> <ul style="list-style-type: none"> <li>• Weather Conditions</li> <li>• Poison Oak</li> <li>• Animals / Insects</li> <li>• Heat Illness</li> <li>• Working Near/Over Water</li> </ul> <p><b><u>MOTOR VEHICLE SAFETY</u></b></p> <ul style="list-style-type: none"> <li>• Driving</li> <li>• Backing</li> <li>• Mountain Terrain</li> <li>• Rural Roads</li> <li>• Traffic</li> <li>• Transporting Loads/Cargo</li> <li>• Trailering/Towing</li> <li>• Inclement Weather Driving</li> <li>• Impaired Driving</li> <li>• Distracted Driving</li> </ul>
--	--	--	---



## Form 2 – Enterprise Contractor Programmatic Safety Plan

*HAZARD MITIGATION: Using your Injury and Illness Prevention Program (IIPP) and the above sample tasks/activity table as a guide, please complete the following JHA to capture actual hazards associated with each proposed activity. Mitigating controls are to be selected according to the hierarchy that uses engineering solutions first, followed by safe work practices, administrative controls, and finally personal protective equipment. The specific hazard mitigation measures used on PG&E work will typically include: (Add task, hazard, mitigation and required training below for each medium and/or high-risk major task performed on behalf of PG&E, including tasks performed by Subcontractors):*

Task/Activity Description	Hazard Description	Contractor's Mitigation Plan	Required Training

***New Hazards and Hazards not previously recognized must be addressed on discovery. Changes must be added to the Change Log in Section 7 of this document.***

## Form 2 – Enterprise Contractor Programmatic Safety Plan

### 3.0 CERTIFICATIONS AND LICENSES

All contract employees, including Subcontractors, covered under this Safety Plan are trained and qualified to perform the task(s) that have been assigned.

- Contractors must ensure that their personnel (including those of Subcontractors) have completed all training required by law and any required PG&E specific courses, including the Contractor Safety Program Orientation (SAFE-0101) and any specific LOB required safety orientations, before conducting work for PG&E.
- Training qualifications must be provided to PG&E for each contract employee prior to the start of work for PG&E.
- Workers must carry their ISN ID cards at all times while working for PG&E and display to PG&E on request.

All training materials must be made available to PG&E on request that shall train all Contractor and Subcontractor personnel on all PG&E's Contractor Safety Program, Contractor's safety program, all job-related hazards, and Applicable Laws.

### 4.0 SITE ORIENTATION

All site personnel, including subcontractors, are required to be introduced and trained on the content and hazard mitigation measures included in this Safety Plan before beginning work on the project. Contractors must document personnel who have completed a review of this Safety Plan, including each worker's name, signature, classification, company name and date. This record must be maintained by the Prime contractor and available by request of PG&E.

### 5.0 CHANGE LOG

Indicate changes made to the Safety Plan in the table below. For each date a change is made, an additional section, 5.0, will need to be completed and must be added as an additional page to the overall Safety Plan. Multiple changes may be required for each date, *please copy additional pages as needed.*

## Form 2 – Enterprise Contractor Programmatic Safety Plan

Date	Reason for Change	Change Description	Section(s) Changed.	PG&E Representative Who Accepted Change

Once the crew has reviewed the changes above, please maintain a signed record that documents the review. This record must be maintained by the Prime contractor and available by request of PG&E.

### 6.0 ATTACHMENTS

<b>INCLUDED ATTACHMENTS:</b>	
<input type="checkbox"/>	Laydown plans
<input type="checkbox"/>	Maps
<input type="checkbox"/>	Other safety submittals, please specify:

### Approval History:

Date:	Approver Name:
-------	----------------





## Enterprise Contractor Safety Plan Management Procedure

### Form 1 - Enterprise Contractor Project Specific Safety Plan



## Enterprise Contractor Project Specific Safety Plan

PG&E PROJECT

CONTRACTOR

LOCATION

CONTRACT/CWA #:

	DOCUMENT DATE:	
	ESTIMATED START DATE:	

**INSTRUCTIONS:** PG&E contractor project manager, safety representative, requestor etc. will complete this form and provide PG&E with a written safety plan using this attached *Project Specific Safety Plan* Form that will document how the contractor and subcontractor, at any tier, will address any anticipated and/or recognized hazards associated with their project/contract work.

This plan is an important step in the communication process to promote open communication between the contractor / subcontractors and PG&E on health and safety expectations and related issues and/or concerns. Detailed plans such as environmental protection, oil management, lift plan, spill mitigation etc. should be attached to this form separately, if applicable. This form along with its attachments, when completed, must be submitted to and approved by PG&E before starting work.



## Enterprise Contractor Safety Plan Management Procedure

### 1.0 GENERAL INFORMATION

Detailed Project Scope Summary (Be as specific as possible):

**Risk Level of Work**

Medium

High



## Enterprise Contractor Safety Plan Management Procedure

		Name(s)	Email	Contact #
<b>PG&amp;E Contacts</b>	<b>Project Lead</b>			
	<b>Work Supervisor</b>			
	<b>Safety Representative</b>			
<b>Contractor Contacts</b>	<b>Safety Plan Author</b>			
	<b>Project Lead</b>			

### 1.1 FIELD LEADERSHIP AND SAFETY OVERSIGHT PLAN

Clearly identify the person(s) responsible for overseeing employees and subcontractors, including a plan for conducting observations and safety meetings:

### 1.2 GENERAL PERSONAL PROTECTIVE EQUIPMENT (PPE) REQUIREMENTS

Contractors are required to provide and ensure that workers use Personal Protective Equipment (PPE) as required by Cal/OSHA (California Code of Regulations [CCR], Title 8, Section 3380) regulatory requirements to perform their work activities safely and when defined in their safety plan, hazard analysis or when required to access a specific PG&E location.

Minimum Personal Protective Equipment required on a jobsite (as required and pertinent to the scope of work):

- Hard hat rated for the scope of work and conditions (ANSI Z89)
- Safety glasses with side shields (ANSI Z87)
- Class 2 or 3 high visibility traffic vest or retroreflective fabric shirt (Arc Rated if appropriate for scope of work)
- Long sleeve shirts and long pants (flame resistant as required & pertinent to scope of work)
- Appropriate footwear (ASTM F2413-05)
- Gloves (as required & pertinent to task)
- Hearing protection (as required at or above 85 Db)

## Enterprise Contractor Safety Plan Management Procedure

- COVID-19 face protection (Flame resistant as required & pertinent to task)
- Any additional PPE as required by your company's IIPP, PG&E contract, or pertinent industry regulations not covered in the above bullets.

Additional PPE requirements must be evaluated when performing specific tasks and must be identified in Section 2 of this document.

### 2.0 RISK ASSESSMENT AND HAZARD IDENTIFICATION

**HAZARD IDENTIFICATION:** Utilize the hazardous energy wheel below to identify energy that can kill you so you may define the hazard controls needed to effectively mitigate those hazards. The hazards encountered as part of this scope could include, but are not limited to:

The hazardous energy wheel is a circular diagram divided into 12 segments, each representing a different type of energy hazard. The segments are: GRAVITY (KG), MOTION, MECHANICAL, TEMPERATURE, PRESSURE, ELECTRICAL, SOUND, RADIATION, BIOLOGICAL, CHEMICAL, TEMPERATURE, and GRAVITY. A central shield icon with a checkmark is surrounded by these segments. Below the wheel is a black box with the text "STKY Stuff That Kills You".

The hazard identification cards are arranged in two rows. The top row includes: Gravity (Falling Load / Suspended Objects), Motion (Mobile Equipment/Traffic with Workers on Foot), Mechanical (Heavy Rotating Equipment), Temperature (Steam), Pressure (Explosion / High-Pressure Projectiles), Electrical (Electrical Contact with High Energy Source), and Chemical / Radiation (High Dose of Toxic Chemical or Radionuclide). The bottom row includes: Motion (ATV / DUV (occupant)), Temperature (Surface Temperature ≥ 150°F), Temperature (Fire with Sustained Fuel Source), Pressure (Excavation or Trench ≥ 5'), Electrical (Arc Flash), Motion (Motor Vehicle (occupant) ≥ 30 mph), and Gravity (Fall from Elevation).

## Enterprise Contractor Safety Plan Management Procedure

<p><b><u>GENERAL HAZARDS</u></b></p> <ul style="list-style-type: none"> <li>• Uneven Ground/ Slips/ Trips &amp; Falls</li> <li>• Confined Spaces</li> <li>• Driving</li> <li>• Power Tool / Equipment Use</li> <li>• Ergonomics</li> <li>• Loading / Off-loading Equipment and Material</li> <li>• Unstable Ground Conditions / Slopes / Uneven terrain</li> <li>• Safety-At-Heights / Scaffolding / Ladders</li> <li>• Cave-ins/ Excavating / Trenching / Shoring</li> <li>• Welding / Oxy Acetylene / Grinding</li> <li>• Hot work</li> <li>• Aggressive Animals / Dogs / Etc.</li> <li>• High Crime Areas</li> <li>• Access</li> <li>• No Cell Service</li> <li>• Night Operations</li> <li>• Wildfire Safety</li> <li>• Dropped Objects</li> </ul> <p><b><u>HEALTH HAZARDS</u></b></p> <ul style="list-style-type: none"> <li>• Chemical Exposure / Burns</li> <li>• Noise Exposure</li> <li>• Pesticides / Fumigation</li> <li>• PCB / Lead / Mercury</li> <li>• Asbestos</li> <li>• Other Soil Contaminants</li> <li>• Hazardous Material Transportation</li> <li>• Hazardous Waste Transportation</li> <li>• Radioactive Exposure</li> </ul>	<p><b><u>PUBLIC SAFETY</u></b></p> <ul style="list-style-type: none"> <li>• Distracted, Impaired, Unsafe Motorists</li> <li>• Vehicular Traffic (Work Area Protection)</li> <li>• Pedestrian Traffic</li> <li>• Proximity to Railroads</li> <li>• Neighboring Facilities/Homeowner Issues</li> </ul> <p><b><u>EXCAVATION</u></b></p> <ul style="list-style-type: none"> <li>• Access / Proximity to Energized Equipment</li> <li>• Proximity to Energized Circuits</li> <li>• OH/UG Energized Lines</li> <li>• Overhead Objects</li> <li>• Appropriate Tools &amp; Equipment</li> <li>• Equipment Certifications</li> <li>• Blasting Safety / Certification</li> <li>• Confined Space</li> <li>• Open Excavation / Fall Restraint</li> <li>• Soil Type / Conditions / Shoring / Sloping</li> <li>• Slopes / Terrain</li> <li>• Spoils Management</li> <li>• USAs</li> </ul> <p><b><u>GAS HAZARDS</u></b></p> <ul style="list-style-type: none"> <li>• Oxygen Deficient Atmosphere</li> <li>• Explosive Atmosphere - Burns / Explosions</li> <li>• Clearance Procedures / LOTO</li> <li>• Dig-Ins / Line Strikes</li> <li>• Unmarked or Mismarked Utilities</li> </ul>	<p><b><u>CRANE</u></b></p> <ul style="list-style-type: none"> <li>• Crane Capacity</li> <li>• Crane Size</li> <li>• Load Weight</li> <li>• Lift Plans</li> <li>• Traffic / Transport</li> <li>• Setup/Access</li> <li>• Stability / Terrain</li> <li>• Rigging</li> <li>• Cribbing</li> <li>• Dangerous Operations</li> <li>• Equipment Certification</li> <li>• Operational Certification</li> <li>• Electrical Hazards</li> <li>• Equipment Grounding</li> <li>• Clearance</li> <li>• Environmental issues</li> <li>• Suspended Loads</li> <li>• Weather Conditions</li> </ul> <p><b><u>TRAFFIC CONTROL / FLAGGING</u></b></p> <ul style="list-style-type: none"> <li>• Environmental Conditions</li> <li>• Non-Compliant Drivers</li> <li>• Pedestrian Safety</li> <li>• Permits</li> <li>• Public Safety</li> <li>• Qualifications / Certifications</li> <li>• Site Specific Hazards</li> <li>• Traffic Control Plan</li> <li>• Low Light Conditions</li> <li>• Weather</li> <li>• Work Site Protection</li> </ul>	<p><b><u>ELECTRICAL HAZARDS</u></b></p> <ul style="list-style-type: none"> <li>• Clearance Procedures / LOTO / Grounding</li> <li>• Underground / Overhead Utilities</li> <li>• Proximity to Energized Equipment</li> <li>• Induction</li> <li>• Energized Work</li> </ul> <p><b><u>AVIATION</u></b></p> <ul style="list-style-type: none"> <li>• External Cargo</li> <li>• Landing Zone Safety</li> <li>• Rigging</li> <li>• Suspended Loads</li> <li>• Flying in a Wire Environment</li> </ul> <p><b><u>ENVIRONMENT HAZARDS</u></b></p> <ul style="list-style-type: none"> <li>• Weather Conditions</li> <li>• Poison Oak</li> <li>• Animals / Insects</li> <li>• Heat Illness</li> <li>• Working Near / Over Water</li> </ul> <p><b><u>MOTOR VEHICLE SAFETY</u></b></p> <ul style="list-style-type: none"> <li>• Driving</li> <li>• Backing</li> <li>• Mountain Terrain</li> <li>• Rural Roads</li> <li>• Traffic</li> <li>• Transporting Loads/Cargo</li> <li>• Trailing/Towing</li> <li>• Inclement Weather Driving</li> <li>• Impaired Driving</li> <li>• Distracted Driving</li> </ul>
---	---	--	---



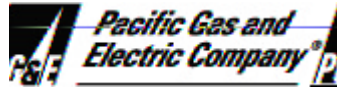

## Enterprise Contractor Safety Plan Management Procedure

*HAZARD MITIGATION: Using your Injury and Illness Prevention Program (IIPP) and the above sample tasks/activity table as a guide, please complete the following JHA to capture actual hazards associated with each proposed activity. Mitigating controls are to be selected according to the hierarchy that uses engineering solutions first, followed by safe work practices, administrative controls, and finally personal protective equipment. The specific hazard mitigation measures used on PG&E work will typically include: (Add task, hazard, mitigation and required training below for each medium and/or high-risk major task performed on behalf of PG&E, including tasks performed by Subcontractors):*

<b>Task/Activity Description</b>	<b>Hazard Description</b>	<b>Contractor's Mitigation Plan</b>	<b>Required Training</b>

***New Hazards and Hazards not previously recognized must be addressed on discovery. Changes shall be added to the Change Log in Section 7 of this document.***



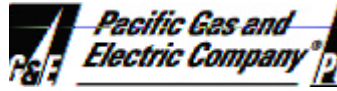

## Enterprise Contractor Safety Plan Management Procedure

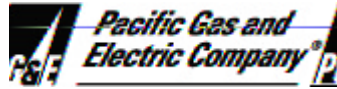

## Enterprise Contractor Safety Plan Management Procedure

### 4.0 EMERGENCY ACTION PLAN

*Purpose:* The following information must be used to ensure an effective and swift response to all emergencies. Please verify that the location is still open, and it is closest to the job site. **An Emergency Action Plan must also be included on the daily JSSA/Tailboard for each jobsite/yard/meeting site.**

Clinic (First Aid)		Hospital	
Name: *		Name: *	
Address: *		Address: *	
Phone #: *		Phone #: *	
Hours of Service: *		Hours of Service: *	
Fire Department		Ambulance	
Name: *		Name: *	
Address:		Address:	
Phone #: *		Phone #: *	
Hours of Service:		Hours of Service:	
Police/Sheriff		811 After Hours Emergency (click <a href="http://us.north811.org/utility-operators/">http://us.north811.org/utility-operators/</a> )	
Name: *		PG&E	(800) 743-5000
Address:			
Phone #: *			
First Aid Kit Location(s) *			
First Aid Kit Location(s) *			
AED Location(s) *			
AED Location(s) *			
Fire Extinguisher Location(s) *			
Fire Extinguisher Location(s) *			
SDS Location(s) *			
SDS Location(s) *			



## Enterprise Contractor Safety Plan Management Procedure

CPR Certified * (names who are certified)	
Cell Phone Reception? If no, provide an alternative communication method. *	

**(\*) Denotes Required Field**

### Map View of Evacuation Plan – **Print and Post**

*Show a map of the location with both primary and secondary meeting locations identified. Use Section 9 (Attachments) to provide additional maps as needed.*



## Enterprise Contractor Safety Plan Management Procedure

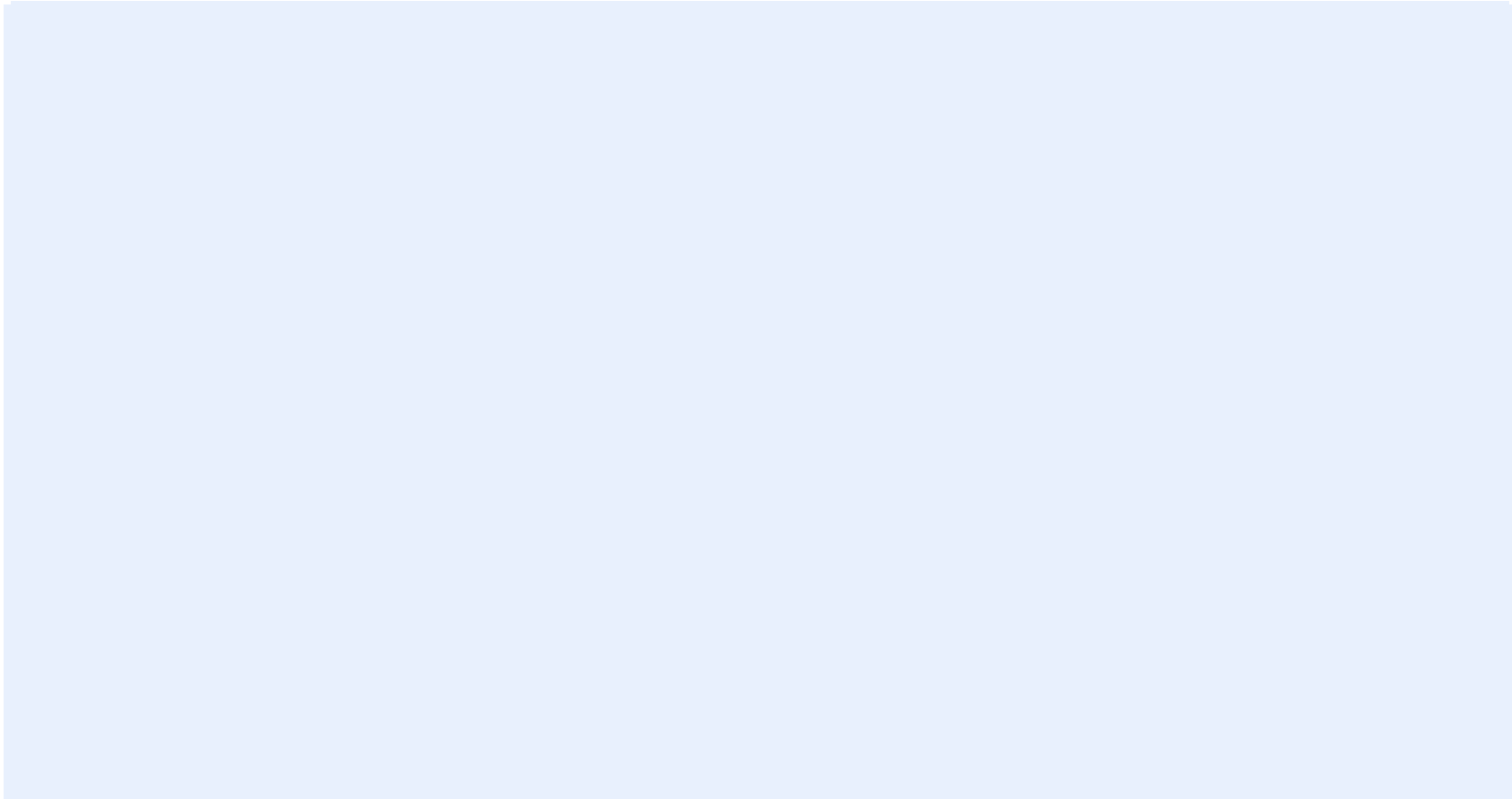

**Map of A and B Meeting Location**

<b>Meeting Location <b>A</b> – please indicate on the map (Primary)</b>	<b>Meeting Location <b>B</b> – please indicate on the map (Secondary)</b>

## Enterprise Contractor Safety Plan Management Procedure

### Map View of Evacuation to Nearest Medical Facility – **Print and Post**

Show a map with directions to the emergency center. Use Section 9 (Attachments) to provide additional maps as needed.

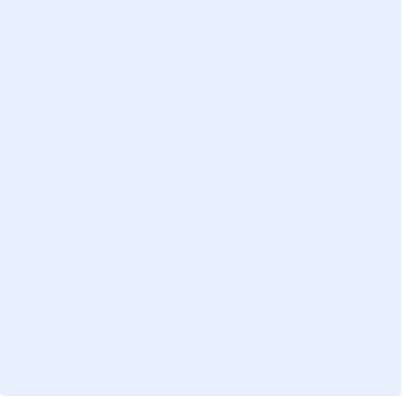
Directions to the Medical Facility	Map to Medical Facility
	



## Enterprise Contractor Safety Plan Management Procedure

### 5.0 CERTIFICATIONS AND LICENSES

All contract employees, including Subcontractors, covered under this Safety Plan are trained and qualified to perform the task(s) that have been assigned.

- Contractors must ensure that their personnel (including those of Subcontractors) have completed all training required by law and any required PG&E specific courses, including the Contractor Safety Program Orientation (SAFE-0101) and any specific LOB required safety orientations, before conducting work for PG&E.
- Training qualifications must be provided to PG&E for each contract employee before the start of work for PG&E.
- Workers must always carry their ISN ID cards while working for PG&E and display to PG&E on request.

All training materials must be made available to PG&E on request that must train all Contractor and Subcontractor personnel on all PG&E's Contractor Safety Program, Contractor's safety program, all job-related hazards, and Applicable Laws.

### 6.0 MANAGING SUBCONTRACTORS, NO SUBCONTRACTORS ANTICIPATED

The Prime contractor must ensure that all Subcontractors have an accepted hard copy of the Safety Plan on site at all times; the scope of work conducted by all Subcontractors shall be covered in this Safety Plan. All Subcontractors Writing Style and Formatting for Procedures also be added to Section 1A of the contract.

Subcontractor Name	Subcontractor Scope	ISN ID #	Risk Level	Subcontractor Contact Name	Subcontractor Contact Phone

## Enterprise Contractor Safety Plan Management Procedure

### 7.0 SITE ORIENTATION

All site personnel, including subcontractors, are required to be introduced and trained on the content and hazard mitigation measures included in this Safety Plan before beginning work on the project. Contractors must document personnel who have completed a review of this Safety Plan, including each worker's name, signature, classification, company name and date. This record must be maintained by the Prime contractor and available by request of PG&E.



## Enterprise Contractor Safety Plan Management Procedure

### 8.0 CHANGE LOG

Indicate changes made to the Safety Plan in the table below. For each date a change is made, an additional section 8.0 will need to be completed and must be added as an additional page to the overall Safety Plan. Multiple changes may be required for each date, *please copy additional pages as needed.*

Date	Reason for Change	Change Description	Section(s) Changed	PG&E Representative Who Accepted Change

Once the crew has reviewed the changes above, please maintain a signed record that documents the review. This record must be maintained by the Prime contractor and available by request of PG&E.

### 9.0 ATTACHMENTS





## Enterprise Contractor Safety Plan Management Procedure

### INCLUDED ATTACHMENTS:

<input type="checkbox"/>	Directions to medical facility*
<input type="checkbox"/>	Evacuation plans*
<input type="checkbox"/>	Parking / Laydown plans
<input type="checkbox"/>	Maps*
<input type="checkbox"/>	Other safety submittals, please specify:

(\*) Denotes Required Field

### Approval History:

Date:	Name of Approver:
-------	-------------------

## **APPENDIX D**

### **General Audit Checklist**



## Worksite Safety Audit

Date & Time:
Auditor Name(s):
Project Name:
Project Address:

ID	Category	Response			Comment
		Yes	No	N/A	
<b>A.</b>	<b>GENERAL WORK ENVIRONMENT</b>				
1.	Are all worksites clean and orderly?				
2.	Are work surfaces kept dry or appropriate means taken to assure the surfaces are slip-resistant?				
3.	Are all spilled materials or liquids cleaned up immediately?				
4.	Is combustible scrap, debris and waste stored safely and removed from the worksite promptly?				
5.	Is accumulated combustible dust routinely removed from elevated surfaces, including the overhead structure of buildings?				
6.	Is combustible dust cleaned up with a vacuum system to prevent the dust going into suspension?				
7.	Is metallic or conductive dust prevented from entering or accumulation on or around electrical enclosures or equipment?				
8.	Are covered metal waste cans used for oily and paint-soaked waste?				
9.	Are all oil and gas fired devices equipped with flame failure controls that will prevent flow of fuel if pilots or main burners are not working?				
10.	Are paint spray booths, dip tanks and the like cleaned regularly?				
11.	Are the minimum number of toilets and washing facilities provided?				
12.	Are all toilets and washing facilities clean and sanitary?				
13.	Are all work areas adequately illuminated?				
14.	Are pits and floor openings covered or otherwise guarded?				
<b>B.</b>	<b>PERSONAL PROTECTIVE EQUIPMENT</b>				
1.	Are protective goggles or face shields provided and worn where there is any danger of flying particles or corrosive materials?				
2.	Are approved safety glasses required to be worn at all times in areas where there is a risk of eye injuries such as punctures, abrasions, contusions or burns?				



ID	Category	Response			Comment
		Yes	No	N/A	
3.	Are employees who need corrective lenses (glasses or contacts lenses) in working environments with harmful exposures, required to wear only approved safety glasses, protective goggles, or use other medically approved precautionary procedures?				
4.	Are protective gloves, aprons, shields, or other means provided against cuts, corrosive liquids and chemicals?				
5.	Are hard hats provided and worn where danger of falling objects exists?				
6.	Are hard hats inspected periodically for damage to the shell and suspension system?				
7.	Is appropriate foot protection required where there is the risk of foot injuries from hot, corrosive, poisonous substances, falling objects, crushing or penetrating actions?				
8.	Are approved respirators provided for regular or emergency use where needed?				
9.	Is all protective equipment maintained in a sanitary condition and ready for use?				
10.	Do you have eye wash facilities and a quick drench shower within the work area where employees are exposed to injurious corrosive materials?				
11.	Where special equipment is needed for electrical workers, is it available?				
12.	When lunches are eaten on the premises, are they eaten in areas where there is no exposure to toxic materials or other health hazards?				
13.	Is protection against the effects of occupational noise exposure provided when sound levels exceed those of the Cal/OSHA noise standard?				
<b>C.</b>	<b>WALKWAYS</b>				
1.	Are aisles and passageways kept clear?				
2.	Are aisles and walkways marked as appropriate?				
3.	Are wet surfaces covered with non-slip materials?				
4.	Are holes in the floor, sidewalk or other walking surface repaired properly, covered or otherwise made safe?				
5.	Is there safe clearance for walking in aisles where motorized or mechanical handling equipment is operating.				
6.	Are spilled materials cleaned up immediately?				



ID	Category	Response			Comment
		Yes	No	N/A	
7.	Are materials or equipment stored in such a way that sharp projectiles will not interfere with the walkway?				
8.	Are changes of direction or elevations readily identifiable?				
9.	Are aisles or walkways that pass near moving or operating machinery, welding operations or similar operations arranged so employees will not be subjected to potential hazards?				
10.	Is adequate headroom provided for the entire length of any aisle or walkway?				
11.	Are standard guardrails provided wherever aisle or walkway surfaces are elevated more than 30 inches above any adjacent floor or the ground?				
12.	Are bridges provided over conveyors and similar hazards?				
<b>D.</b>	<b>FLOOR AND WALL STAIRWAYS</b>				
1.	Are floor openings guarded by a cover, guardrail, or equivalent on all sides (except at entrance to stairways or ladders)?				
2.	Are toe boards installed around the edges of a permanent floor opening (where persons may pass below the opening)?				
3.	Are skylight screens of such construction and mounting that they will withstand a load of at least 200 pounds?				
4.	Is the glass in windows, doors, glass walls that are subject to human impact, of sufficient thickness and type for the condition of use?				
5.	Are grates or similar type covers over floor openings such as floor drains, of such design that foot traffic or rolling equipment will not be affected by the grate spacing?				
6.	Are unused portions of service pits and pits not actually in use either covered or protected by guardrails or equivalent?				
7.	Are manhole covers, trench covers and similar covers, plus their supports, designed to carry a truck rear axle load of at least 20,000 pounds when located in roadways and subject to vehicle traffic?				
8.	Are floor or wall openings in fire resistive construction provided with doors or covers compatible with the fire rating of the structure and provided with self-closing feature when appropriate?				
<b>E.</b>	<b>STAIRS &amp; STAIRWAYS</b>				
1.	Are standard stair rails or handrails on all stairways having four or more risers?				
2.	Are all stairways at least 22 inches wide?				





ID	Category	Response			Comment
		Yes	No	N/A	
3.	Do stairs have at least a 6'6" overhead clearance?				
4.	Do stairs angle no more than 50 and no less than 30 degrees?				
5.	Are stairs of hollow-pan type treads and landings filled to noising level with solid material?				
6.	Are step risers on stairs uniform from top to bottom, with no riser spacing greater than 7-1/2 inches?				
7.	Are steps on stairs and stairways designed or provided with a surface that renders them slip resistant?				
8.	Are stairway handrails located between 30 and 34 inches above the leading edge of stair treads?				
9.	Do stairway handrails have a least 1-1/2 inches of clearance between the handrails and the wall or surface they are mounted on?				
10.	Are stairway handrails capable of withstanding a load of 200 pounds, applied in any direction?				
11.	Where stairs or stairways exit directly into any area where vehicles may be operated, are adequate barriers and warnings provided to prevent employees stepping into the path of traffic?				
12.	Do stairway landings have a dimension measured in the direction of travel, at least equal to width of the stairway?				
13.	Is the vertical distance between stairway landings limited to 12 feet or less?				
<b>F.</b>	<b>ELEVATED SURFACES</b>				
1.	Are signs posted, when appropriate, showing the elevated surface load capacity?				
2.	Are surfaces elevated more than 30 inches above the floor or ground provided with standard guardrails?				
3.	Are all elevated surfaces (beneath which people or machinery could be exposed to falling objects) provided with standard 4-inch toe boards?				
4.	Is a permanent means of access and egress provided to elevated storage and work surfaces?				
5.	Is required headroom provided where necessary?				
6.	Is material on elevated surfaces piled, stacked or racked in a manner to prevent it from tipping, falling, collapsing, rolling or spreading?				



ID	Category	Response			Comment
		Yes	No	N/A	
7.	Are dock boards or bridge plates used when transferring materials between docks and trucks or rail cars?				
<b>G.</b>	<b>EXITING OR EGRESS</b>				
1.	Are all exits marked with an exit sign and illuminated by a reliable light source?				
2.	Are the directions to exits, when not immediately apparent, marked with visible signs?				
3.	Are doors, passageways or stairways, that are neither exits nor access to exits and which could be mistaken for exits, appropriately marked "NOT AN EXIT", "TO BASEMENT", "STOREROOM", and the like?				
4.	Are exit signs provided with the word "EXIT" in lettering at least 5 inches high and the stroke of the lettering at least 1/2 inch wide?				
5.	Are exit doors side-hinged?				
6.	Are all exits kept free of obstructions?				
7.	Are at least two means of egress provided from elevated platforms, pits or rooms where the absence of a second exit would increase the risk of injury from hot, poisonous, corrosive, suffocating, flammable, or explosive substances?				
8.	Are there sufficient exits to permit prompt escape in case of emergency?				
9.	Are special precautions taken to protect employees during construction and repair operations?				
10.	Is the number of exits from each floor of a building, and the number of exits from the building itself, appropriate for the building occupancy load?				
11.	Are exit stairways which are required to be separated from other parts of a building enclosed by at least two-hour fire-resistive construction in buildings more than four stories in height, and not less than one-hour fire resistive construction elsewhere?				
12.	When ramps are used as part of required exiting from a building, is the ramp slope limited to 1- foot vertical and 12 feet horizontal?				
13.	Where exiting will be through frameless glass doors, glass exit doors, storm doors, and such are the doors fully tempered and meet the safety requirements for human impact?				
<b>H.</b>	<b>EXIT DOORS</b>				



ID	Category	Response			Comment
		Yes	No	N/A	
1.	Are doors that are required to serve as exits designed and constructed so that the way of exit travel is obvious and direct?				
2.	Are windows that could be mistaken for exit doors, made inaccessible by means of barriers or railings?				
3.	Are exit doors openable from the direction of exit travel without the use of a key or any special knowledge or effort, when the building is occupied?				
4.	Is a revolving, sliding or overhead door prohibited from serving as a required exit door?				
5.	Where panic hardware is installed on a required exit door, will it allow the door to open by applying a force of 15 pounds or less in the direction of the exit traffic?				
6.	Are doors on cold storage rooms provided with an inside release mechanism that will release the latch and open the door even if it's padlocked or otherwise locked on the outside?				
7.	Where exit doors open directly onto any street, alley or other area where vehicles may be operated, are adequate barriers and warnings provided to prevent employees stepping into the path of traffic?				
8.	Are doors that swing in both directions and are located between rooms where there is frequent traffic, provided with viewing panels in each door?				
<b>1.</b>	<b>PORTABLE LADDERS</b>				
1.	Are all ladders maintained in good condition, joints between steps and side rails tight, all hardware and fittings securely attached, and moveable parts operating freely without binding or undue play?				
2.	Are non-slip safety feet provided on each ladder?				
3.	Are non-slip safety feet provided on each metal or rung ladder?				
4.	Are ladder rungs and steps free of grease and oil?				
5.	Is it prohibited to place a ladder in front of doors opening toward the ladder except when the door is blocked open, locked or guarded?				
6.	Is it prohibited to place ladders on boxes, barrels, or other unstable bases to obtain additional height?				
7.	Are employees instructed to face the ladder when ascending or descending?				



ID	Category	Response			Comment
		Yes	No	N/A	
8.	Are employees prohibited from using ladders that are broken, missing steps, rungs, or cleats, broken side rails or other faulty equipment?				
9.	Are employees instructed not to use the top 2 steps of ordinary stepladders as a step?				
10.	When portable rung ladders are used to gain access to elevated platforms, roofs, and the like does the ladder always extend at least 3 feet above the elevated surface?				
11.	Is it required that when portable rung or cleat type ladders are used the base is so placed that slipping will not occur, or it is lashed or otherwise held in place?				
12.	Are portable metal ladders legibly marked with signs reading "CAUTION" "Do Not Use Around Electrical Equipment" or equivalent wording?				
13.	Are employees prohibited from using ladders as guys, braces, skids, gin poles, or for other than their intended purposes?				
14.	Are employees instructed to only adjust extension ladders while standing at a base (not while standing on the ladder or from a position above the ladder)?				
15.	Are metal ladders inspected for damage?				
16.	Are the rungs of ladders uniformly spaced at 12 inches, center to center?				
J.	<b>HAND TOOLS &amp; EQUIPMENT</b>				
1.	Are all tools and equipment (both, company and employee-owned) used by employees at their workplace in good condition?				
2.	Are hand tools such as chisels, punches, which develop mushroomed heads during use, reconditioned or replaced as necessary?				
3.	Are broken or fractured handles on hammers, axes and similar equipment replaced promptly?				
4.	Are worn or bent wrenches replaced regularly?				
5.	Are appropriate handles used on files and similar tools?				
6.	Are employees made aware of the hazards caused by faulty or improperly used hand tools?				
7.	Are appropriate safety glasses, face shields, and similar equipment used while using hand tools or equipment that might produce flying materials or be subject to breakage?				



ID	Category	Response			Comment
		Yes	No	N/A	
8.	Are jacks checked periodically to assure they are in good operating condition?				
9.	Are tool handles wedged tightly in the head of all tools?				
10.	Are tool cutting edges kept sharp, so the tool will move smoothly without binding or skipping?				
11.	Are tools stored in dry, secure location where they won't be tampered with?				
12.	Is eye and face protection used when driving hardened or tempered spuds or nails?				
<b>K.</b>	<b>PORTABLE (POWER OPERATED) TOOLS &amp; EQUIPMENT</b>				
1.	Are grinders, saws, and similar equipment provided with appropriate safety guards?				
2.	Are power tools used with the correct shield, guard or attachment recommended by the manufacturer?				
3.	Are portable circular saws equipped with guards above and below the base shoe?				
4.	Are circular saw guards checked to assure they are not wedged up, thus leaving the lower portion of the blade unguarded?				
5.	Are rotating or moving parts of equipment guarded to prevent physical contact?				
6.	Are all cord-connected, electrically operated tools and equipment effectively grounded or of the approved double insulated type?				
7.	Are effective guards in place over belts, pulleys, chains, and sprockets, on equipment such as concrete mixers, air compressors, and the like?				
8.	Are portable fans provided with full guards or screens having openings 1/2 inch or less?				
9.	Is hoisting equipment available and used for lifting heavy objects, and are hoist ratings and characteristics appropriate for the task?				
10.	Are ground-fault circuit interrupters provided on all temporary electrical 15 and 20 ampere circuits, used during periods of construction?				
11.	Are pneumatic and hydraulic hoses on power-operated tools checked regularly for deterioration or damage?				
<b>L.</b>	<b>ABRASIVE WHEEL EQUIPMENT GRINDERS</b>				
1.	Is the work rest used and kept adjusted to within 1/8 inch of the wheel?				
2.	Is the adjustable tongue on the top side of the grinder used and kept adjusted to within 1/4 inch of the wheel?				





ID	Category	Response			Comment
		Yes	No	N/A	
3.	Do side guards cover the spindle, nut, and flange and 75 percent of the wheel diameter?				
4.	Are bench and pedestal grinders permanently mounted?				
5.	Are goggles or face shields always worn when grinding?				
6.	Is the maximum RPM rating of each abrasive wheel compatible with the RPM rating of the grinder motor?				
7.	Are fixed or permanently mounted grinders connected to their electrical supply system with metallic conduit or other permanent wiring method?				
8.	Does each grinder have an individual on and off control switch?				
9.	Is each electrically operated grinder effectively grounded?				
10.	Before new abrasive wheels are mounted, are they visually inspected and ring tested?				
11.	Are dust collectors and powered exhausts provided on grinders used in operations that produce large amounts of dust?				
12.	Are splashguards mounted on grinders that use coolant, to prevent the coolant reaching employees?				
13.	Is cleanliness maintained around grinder?				
<b>M.</b>	<b>POWDER ACTUATED TOOLS</b>				
1.	Are employees who operate powder-actuated tools trained in their use and carry a valid operator's card?				
2.	Do the powder-actuated tools being used have written approval of the Division of Occupational Safety and Health?				
3.	Is each powder-actuated tool stored in its own locked container when not being used?				
4.	Is a sign at least 7" by 10" with bold type reading "POWDER-ACTUATED TOOL IN USE" conspicuously posted when the tool is being used?				
5.	Are powder-actuated tools left unloaded until they are actually ready to be used?				
6.	Are powder-actuated tools inspected for obstructions or defects each day before use?				
7.	Do powder-actuated tools operators have and use appropriate personal protective equipment such as hard hats, safety goggles, safety shoes and ear protectors?				
<b>N.</b>	<b>MACHINE GUARDING</b>				



ID	Category	Response			Comment
		Yes	No	N/A	
1.	Is there a training program to instruct employees on safe methods of machine operation?				
2.	Is there adequate supervision to ensure that employees are following safe machine operating procedures?				
3.	Is there a regular program of safety inspection of machinery and equipment?				
4.	Is all machinery and equipment kept clean and properly maintained?				
5.	Is sufficient clearance provided around and between machines to allow for safe operations, set up and servicing, material handling and waste removal?				
6.	Is equipment and machinery securely placed and anchored, when necessary to prevent tipping or other movement that could result in personal injury?				
7.	Is there a power shut-off switch within reach of the operator's position at each machine?				
8.	Can electric power to each machine be locked out for maintenance, repair, or security?				
9.	Are the noncurrent-carrying metal parts of electrically operated machines bonded and grounded?				
10.	Are foot-operated switches guarded or arranged to prevent accidental actuation by personnel or falling?				
11.	Are manually operated valves and switches controlling the operation of equipment and machines clearly identified and readily accessible?				
12.	Are all emergency stop buttons colored red?				
13.	Are all pulleys and belts that are within 7 feet of the floor or working level properly guarded?				
14.	Are all moving chains and gears properly guarded?				
15.	Are splashguards mounted on machines that use coolant, to prevent the coolant from reaching employees?				
16.	Are methods provided to protect the operator and other employees in the machine area from hazards created at the point of operation, ingoing nip points, rotating parts, flying chips, and sparks?				
17.	Are machinery guards secure and so arranged that they do not offer a hazard in their use?				



ID	Category	Response			Comment
		Yes	No	N/A	
18.	If special hand tools are used for placing and removing material, do they protect the operator's hands?				
19.	Are revolving drums, barrels, and containers required to be guarded by an enclosure that is interlocked with the drive mechanism, so that revolution cannot occur unless the guard enclosure is in place, so guarded?				
20.	Do arbors and mandrels have firm and secure bearings and are they free from play?				
21.	Are provisions made to prevent machines from automatically starting when power is restored after a power failure or shutdown?				
22.	Are machines constructed so as to be free from excessive vibration when the largest size tool is mounted and run at full speed?				
23.	If machinery is cleaned with compressed air, is air pressure controlled and personal protective equipment or other safeguards used to protect operators and other workers from eye and body injury?				
24.	Are fan blades protected with a guard having openings no larger than 1/2 inch, when operating within 7 feet of the floor?				
25.	Are saws used for ripping, equipped with anti-kick back devices and spreaders?				
26.	Are radial arm saws so arranged that the cutting head will gently return to the back of the table when released?				
O.	<b>LOCKOUT BLOCKOUT PROCEDURES</b>				
1.	Is all machinery or equipment capable of movement, required to be de-energized or disengaged and blocked or locked out during cleaning, servicing, adjusting or setting up operations, whenever required?				
2.	Is the locking-out of control circuits in lieu of locking-out main power disconnects prohibited?				
3.	Are all equipment control valve handles provided with a means for locking-out?				
4.	Does the lockout procedure require that stored energy (i.e. mechanical, hydraulic, air,) be released or blocked before equipment is locked-out for repairs?				
5.	Are appropriate employees provided with individually keyed personal safety locks?				
6.	Are employees required to keep personal control of their key(s) while they have safety locks in use?				
7.	Is it required that employees check the safety of the lock out by attempting a start up after making sure no one is exposed?				



ID	Category	Response			Comment
		Yes	No	N/A	
8.	Where the power disconnecting means for equipment does not also disconnect the electrical control circuit:				
9.	Are the appropriate electrical enclosures identified?				
10.	Is means provide to assure the control circuit can also be disconnected and locked out?				
<b>P.</b>	<b>WELDING, CUTTING &amp; BRAZING</b>				
1.	Are only authorized, and trained personnel permitted to use welding, cutting or brazing equipment?				
2.	Do all operator have a copy of the appropriate operating instructions and are they directed to follow them?				
3.	Are compressed gas cylinders regularly examined for obvious signs of defects, deep rusting, or leakage?				
4.	Is care used in handling and storage of cylinders, safety valves, relief valves, and the like, to prevent damage?				
5.	Are precautions taken to prevent the mixture of air or oxygen with flammable gases, except at a burner or in a standard torch?				
6.	Are only approved apparatus (torches, regulators, pressure-reducing valves, acetylene generators, manifolds) used?				
7.	Are cylinders kept away from sources of heat?				
8.	Is it prohibited to use cylinders as rollers or supports?				
9.	Are empty cylinders appropriately marked their valves closed and valve-protection caps on?				
10.	Are signs reading: DANGER NO-SMOKING, MATCHES, OR OPEN LIGHTS, or the equivalent posted?				
11.	Are cylinders, cylinder valves, couplings, regulators, hoses, and apparatus keep free of oily or greasy substances?				
12.	Is care taken not to drop or strike cylinders?				
13.	Unless secured on special trucks, are regulators removed and valve-protection caps put in place before moving cylinders?				
14.	Do cylinders without fixed hand wheels have keys, handles, or non-adjustable wrenches on stem valves when in service?				
15.	Are liquefied gases stored and shipped valve-end up with valve covers in place?				
16.	Are employees instructed to never crack a fuel-gas cylinder valve near sources of ignition?				



ID	Category	Response			Comment
		Yes	No	N/A	
17.	Before a regulator is removed, is the valve closed and gas released from the regulator?				
18.	Is red used to identify the acetylene (and other fuel-gas) hose, green for oxygen hose, and black for inert gas and air hose?				
19.	Are pressure-reducing regulators used only for the gas and pressures for which they are intended?				
20.	Is open circuit (No Load) voltage of arc welding and cutting machines as low as possible and not in excess of the recommended limits?				
21.	Under wet conditions, are automatic controls for reducing no-load voltage used?				
22.	Is grounding of the machine frame and safety ground connections of portable machines checked periodically?				
23.	Are electrodes removed from the holders when not in use?				
24.	Is it required that electric power to the welder be shut off when no one is in attendance?				
25.	Is suitable fire extinguishing equipment available for immediate use?				
26.	Is the welder forbidden to coil or loop welding electrode cable around his body?				
27.	Are wet machines thoroughly dried and tested before being used?				
28.	Are work and electrode lead cables frequently inspected for wear and damage, and replaced when needed?				
29.	Do means for connecting cables' lengths have adequate insulation?				
30.	When the object to be welded cannot be moved and fire hazards cannot be removed, are shields used to confine heat, sparks, and slag?				
31.	Are firewatchers assigned when welding or cutting is performed, in locations where a serious fire might develop?				
32.	Are combustible floors kept wet, covered by damp sand, or protected by fire-resistant shields?				
33.	When floors are wet down, are personnel protected from possible electrical shock?				
34.	When welding is done on metal walls, are precautions taken to protect combustibles on the other side?				
35.	Before hot work is begun, are used drums, barrels, tanks, and other containers so thoroughly cleaned that no substances remain that could explode, ignite, or produce toxic vapors?				





ID	Category	Response			Comment
		Yes	No	N/A	
36.	Is it required that eye protection helmets, hand shields and goggles meet appropriate standards?				
37.	Are employees exposed to the hazards created by welding, cutting, or bracing operations protected with personal protective equipment and clothing?				
38.	Is a check made for adequate ventilation in and where welding or cutting is preformed?				
39.	When working in confined places are environmental monitoring tests taken and means provided for quick removal of welders in case of an emergency?				
<b>Q.</b>	<b>COMPRESSORS &amp; COMPRESSED AIR</b>				
1.	Are compressors equipped with pressure relief valves, and pressure gauges?				
2.	Are compressor air intakes installed and equipped to ensure that only clean uncontaminated air enters the compressor?				
3.	Are air filters installed on the compressor intake?				
4.	Are compressors operated and lubricated in accordance with the manufacturer's recommendations?				
5.	Are safety devices on compressed air systems checked frequently?				
6.	Before any repair work is done on the pressure system of a compressor, is the pressure bled off and the system locked-out?				
7.	Are signs posted to warn of the automatic starting feature of the compressors?				
8.	Is the belt drive system totally enclosed to provide protection for the front, back, top, and sides?				
9.	Is it strictly prohibited to direct compressed air towards a person?				
10.	Are employees prohibited from using highly compressed air for cleaning purposes?				
11.	If compressed air is used for cleaning off clothing, is the pressure reduced to less than 10 psi?				
12.	When using compressed air for cleaning, do employees use personal protective equipment?				
13.	Are safety chains or other suitable locking devices used at couplings of high pressure hose lines where a connection failure would create a hazard?				
14.	Before compressed air is used to empty containers of liquid, is the safe working pressure of the container checked?				



ID	Category	Response			Comment
		Yes	No	N/A	
15.	When compressed air is used with abrasive blast cleaning equipment, is the operating valve a type that must be held open manually?				
16.	When compressed air is used to inflate auto tires, is a clip-on chuck and an inline regulator preset to 40 psi required?				
17.	Is it prohibited to use compressed air to clean up or move combustible dust if such action could cause the dust to be suspended in the air and cause a fire or explosion hazard?				
<b>R.</b>	<b>COMPRESSED AIR RECEIVERS</b>				
1.	Is every receiver equipped with a pressure gauge and with one or more automatic, spring-loaded safety valves?				
2.	Is the total relieving capacity of the safety valve capable of preventing pressure in the receiver from exceeding the maximum allowable working pressure of the receiver by more than 10 percent?				
3.	Is every air receiver provided with a drainpipe and valve at the lowest point for the removal of accumulated oil and water?				
4.	Are compressed air receivers periodically drained of moisture and oil?				
5.	Are all safety valves tested frequently and at regular intervals to determine whether they are in good operating condition?				
6.	Is there a current operating permit issued by the Division of Occupational Safety and Health?				
7.	Is the inlet of air receivers and piping systems kept free of accumulated oil and carbonaceous materials?				
<b>S.</b>	<b>COMPRESSED GAS &amp; CYLINDERS</b>				
1.	Are cylinders with a water weight capacity over 30 pounds equipped with means for connecting a valve protector device, or with a collar or recess to protect the valve?				
2.	Are cylinders legibly marked to clearly identify the gas contained?				
3.	Are compressed gas cylinders stored in areas which are protected from external heat sources such as flame impingement, intense radiant heat, electric arcs, or high temperature lines?				
4.	Are cylinders located or stored in areas where they will not be damaged by passing or falling objects, or subject to tampering by unauthorized persons?				
5.	Are cylinders stored or transported in a manner to prevent them creating a hazard by tipping, falling or rolling?				



ID	Category	Response			Comment
		Yes	No	N/A	
6.	Are cylinders containing liquefied fuel gas, stored or transported in a position so that the safety relief device is always in direct contact with the vapor space in the cylinder?				
7.	Are valve protectors always placed on cylinders when the cylinders are not in use or connected for use?				
8.	Are all valves closed off before a cylinder is moved, when the cylinder is empty, and at the completion of each job?				
9.	Are low pressure fuel-gas cylinders checked periodically for corrosion, general distortion, cracks, or any other defect that might indicate a weakness or render it unfit for service?				
10.	Does the periodic check of low pressure fuel-gas cylinders include a close inspection of the cylinders' bottom?				
<b>T.</b>	<b>HOIST &amp; AUXILIARY EQUIPMENT</b>				
1.	Is each overhead electric hoist equipped with a limit device to stop the hook travel at its highest and lowest point of safe travel?				
2.	Will each hoist automatically stop and hold any load up to 125 percent of its rated load, if its actuating force is removed?				
3.	Is the rated load of each hoist legibly marked and visible to the operator?				
4.	Are stops provided at the safe limits of travel for trolley hoist?				
5.	Are the controls of hoists plainly marked to indicate the direction of travel or motion?				
6.	Is each cage-controlled hoist equipped with an effective warning device?				
7.	Are close-fitting guards or other suitable devices installed on hoist to assure hoist ropes will be maintained in the sheave groves?				
8.	Are all hoist chains or ropes of sufficient length to handle the full range of movement for the application while still maintaining two full wraps on the drum at all times?				
9.	Are nip points or contact points between hoist ropes and sheaves which are permanently located within 7 feet of the floor, ground or working platform, guarded?				
10.	Is it prohibited to use chains or rope slings that are kinked or twisted?				
11.	Is it prohibited to use the hoist rope or chain wrapped around the load as a substitute, for a sling?				
12.	Is the operator instructed to avoid carrying loads over people?				



ID	Category	Response			Comment
		Yes	No	N/A	
13.	Are only employees who have been trained in the proper use of hoists allowed to operate them?				
U.	<b>INDUSTRIAL TRUCKS - FORKLIFTS</b>				
1.	Are only trained personnel allowed to operate industrial trucks?				
2.	Is substantial overhead protective equipment provided on high lift rider equipment?				
3.	Are the required lift truck operating rules posted and enforced?				
4.	Is directional lighting provided on each industrial truck that operates in an area with less than 2-foot candles per square foot of general lighting?				
5.	Does each industrial truck have a warning horn, whistle, gong or other device which can be clearly heard above the normal noise in the areas where operated?				
6.	Are the brakes on each industrial truck capable of bringing the vehicle to a complete and safe stop when fully loaded?				
7.	Will the industrial truck's parking brake effectively prevent the vehicle from moving when unattended?				
8.	Are industrial trucks operating in areas where flammable gases or vapors, or combustible dust or ignitable fibers may be present in the atmosphere, approved for such locations?				
9.	Are motorized hand and hand/rider trucks so designed that the brakes are applied, and power to the drive motor shuts off when the operator releases his/her grip on the device that controls the travel?				
10.	Are industrial trucks with internal combustion engine operated in buildings or enclosed areas, carefully checked to ensure such operations do not cause harmful concentration of dangerous gases or fumes?				
V.	<b>SPRAYING OPERATIONS</b>				
1.	Is adequate ventilation assured before spray operations are started?				
2.	Is mechanical ventilation provided when spraying operation is done in enclosed areas?				
3.	When mechanical ventilation is provided during spraying operations, is it so arranged that it will not circulate the contaminated air?				
4.	Is the spray area free of hot surfaces?				



ID	Category	Response			Comment
		Yes	No	N/A	
5.	Is the spray area at least 20 feet from flames, sparks, operating electrical motors and other ignition sources?				
6.	Are portable lamps used to illuminate spray areas suitable for use in a hazardous location?				
7.	Is approved respiratory equipment provided and used when appropriate during spraying operations?				
8.	Do solvents used for cleaning have a flash point of 100E F or more?				
9.	Are fire control sprinkler heads kept clean?				
10.	Are "NO SMOKING" signs posted in spray areas, paint rooms, paint booths, and paint storage areas?				
11.	Is the spray area kept clean of combustible residue?				
12.	Are spray booths constructed of metal, masonry, or other substantial noncombustible material?				
13.	Are spray booth floors and baffles noncombustible and easily cleaned?				
14.	Is infrared drying apparatus kept out of the spray area during spraying operations?				
15.	Is the spray booth completely ventilated before using the drying apparatus?				
16.	Is the electric drying apparatus properly grounded?				
17.	Are lighting fixtures for spray booths located outside of the booth and the interior lighted through sealed clear panels?				
18.	Are the electric motors for exhaust fans placed outside booths or ducts?				
19.	Are belts and pulleys inside the booth fully enclosed?				
20.	Do ducts have access doors to allow cleaning?				
21.	Do all drying spaces have adequate ventilation?				
W.	<b>ENTERING CONFINED SPACES</b>				
1.	Confined space properly classified and posted Permit Required Confined Space (PRCS) or non-PRCS?				
2.	Are confined spaces thoroughly emptied of any corrosive or hazardous substances, such as acids or caustics, before entry?				
3.	Before entry, are all lines to a confined space, containing inert, toxic, flammable, or corrosive materials valved off and blanked or disconnected and separated?				





ID	Category	Response			Comment
		Yes	No	N/A	
4.	Is it required that all impellers, agitators, or other moving equipment inside confined spaces be locked-out if they present a hazard?				
5.	Is either natural or mechanical ventilation provided prior to confined space entry?				
6.	Before entry, are appropriate atmospheric tests performed to check for oxygen deficiency, toxic substance, and explosive concentrations in the confined space before entry?				
7.	Is adequate illumination provided for the work to be performed in the confined space?				
8.	Is the atmosphere inside the confined space frequently tested or continuously monitor during conduct of work?				
9.	Is there an assigned safety standby employee outside of the confined space, whose sole responsibility is to watch the work in progress, sound an alarm if necessary, and render assistance?				
10.	Is the standby employee or other employees prohibited from entering the confined space without lifelines and respiratory equipment if there is any questions as to the cause of an emergency?				
11.	In addition to the standby employee, is there at least one other trained rescuer in the vicinity?				
12.	Are all rescuers appropriately trained and using approved, recently inspected equipment?				
13.	Does all rescue equipment allow for lifting employees vertically from a top opening?				
14.	Are there trained personnel in First Aid and CPR immediately available?				
15.	Is there an effective communication system in place whenever respiratory equipment is used and the employee in the confined space is out of sight of the standby person?				
16.	Is approved respiratory equipment required and available if the atmosphere inside the confined space cannot be made acceptable?				
17.	Is all portable electrical equipment used inside confined spaces either grounded and insulated, or equipped with ground fault protection?				



ID	Category	Response			Comment
		Yes	No	N/A	
18.	Before gas welding or burning is started in a confined space, are hoses checked for leaks, compressed gas bottles forbidden inside of the confined space, torches lighted only outside of the confined area and the confined area tested for an explosive atmosphere each time before a lighted torch is to be taken into the confined space?				
19.	If employees will be using oxygen-consuming equipment such as salamanders, torches, furnaces, in a confined space, is sufficient air provided to assure combustion without reducing the oxygen concentration of the atmosphere below 19.5 percent by volume?				
20.	Whenever combustion-type equipment is used in confined space, are provisions made to ensure the exhaust gases are vented outside of the enclosure?				
21.	Is each confined space checked for decaying vegetation or animal matter, which may produce methane?				
22.	Is the confined space checked for possible industrial waste, which could contain toxic properties?				
23.	If the confined space is below the ground and near areas where motor vehicles will be operating, is it possible for vehicle exhaust or carbon monoxide to enter the space?				
X.	<b>ENVIRONMENTAL CONTROLS</b>				
1.	Are all work areas properly illuminated?				
2.	Are employees instructed in proper first aid and other emergency procedures?				
3.	Are hazardous substances identified which may cause harm by inhalation, ingestion, skin absorption or contact?				
4.	Are employees aware of the hazards involved with the various chemicals they may be exposed to in their work environment, such as ammonia, chlorine, epoxies, and caustics?				
5.	Is employee exposure to chemicals in the workplace kept within acceptable levels?				
6.	Can a less harmful method or product be used?				
7.	Is the work area's ventilation system appropriate for the work being performed?				
8.	Are spray painting operations done in spray rooms or booths equipped with an appropriate exhaust system?				



ID	Category	Response			Comment
		Yes	No	N/A	
9.	Is employee exposure to welding fumes controlled by ventilation, use of respirators, exposure time, or other means?				
10.	Are welders and other workers nearby provided with flash shields during welding operations?				
11.	If forklifts and other vehicles are used in buildings or other enclosed areas, are the carbon monoxide levels kept below maximum acceptable concentration?				
12.	Has there been a determination that noise levels in the facilities are within acceptable levels?				
13.	Are steps being taken to use engineering controls to reduce excessive noise levels?				
14.	Are proper precautions being taken when handling asbestos and other fibrous materials?				
15.	Are caution labels and signs used to warn of asbestos?				
16.	Are wet methods used, when practicable, to prevent the emission of airborne asbestos fibers, silica dust and				
17.	similar hazardous materials?				
18.	Is vacuuming with appropriate equipment used whenever possible rather than blowing or sweeping dust?				
19.	Are grinders, saws, and other machines that produce respirable dusts vented to an industrial collector or central exhaust system?				
20.	Are all local exhaust ventilation systems designed and operating properly such as airflow and volume necessary for the application? Are the ducts free of obstructions or the belts slipping?				
21.	Is personal protective equipment provided, used and maintained wherever required?				
22.	Are there written standard operating procedures for the selection and use of respirators where needed?				
23.	Are restrooms and washrooms kept clean and sanitary?				
24.	Is all water provided for drinking, washing, and cooking potable?				
25.	Are all outlets for water not suitable for drinking clearly identified?				
26.	Are employees' physical capacities assessed before being assigned to jobs requiring heavy work?				
27.	Are employees instructed in the proper manner of lifting heavy objects?				

ID	Category	Response			Comment
		Yes	No	N/A	
28.	Where heat is a problem, have all fixed work areas been provided with spot cooling or air conditioning?				
29.	Are employees screened before assignment to areas of high heat to determine if their health condition might				
30.	make them more susceptible to having an adverse reaction?				
31.	Are employees working on streets and roadways where they are exposed to the hazards of traffic, required to wear bright colored (traffic orange) warning vest?				
32.	Are exhaust stacks and air intakes located that contaminated air will not be recirculated within a building or other enclosed area?				
33.	Is equipment producing ultra-violet radiation properly shielded?				
<b>Y.</b>	<b>FLAMMABLE &amp; COMBUSTIBLE MATERIALS</b>				
1.	Are combustible scrap, debris and waste materials (i.e. oily rags) stored in covered metal receptacles and removed from the worksite promptly?				
2.	Is proper storage practiced to minimize the risk of fire including spontaneous combustion?				
3.	Are approved containers and tanks used for the storage and handling of flammable and combustible liquids?				
4.	Are all connections on drums and combustible liquid piping, vapor and liquid tight?				
5.	Are all flammable liquids kept in closed containers when not in use (e.g. parts cleaning tanks, pans)?				
6.	Are bulk drums of flammable liquids grounded and bonded to containers during dispensing?				
7.	Do storage rooms for flammable and combustible liquids have explosion-proof lights?				
8.	Do storage rooms for flammable and combustible liquids have mechanical or gravity ventilation?				
9.	Is liquefied petroleum gas stored, handled, and used in accordance with safe practices and standards?				
10.	Are liquefied petroleum storage tanks guarded to prevent damage from vehicles?				
11.	Are all solvent wastes and flammable liquids kept in fire-resistant covered containers until they are removed from the worksite?				



ID	Category	Response			Comment
		Yes	No	N/A	
12.	Is vacuuming used whenever possible rather than blowing or sweeping combustible dust?				
13.	Are fire separators placed between containers of combustibles or flammables, when stacked one upon another, to assure their support and stability?				
14.	Are fuel gas cylinders and oxygen cylinders separated by distance, fire resistant barriers or other means while in storage?				
15.	Are fire extinguishers selected and provided for the types of materials in areas where they are to be used?				
16.	Class A: Ordinary combustible material fires.				
17.	Class B: Flammable liquid, gas or grease fires.				
18.	Class C: Energized-electrical equipment fires.				
19.	If a Halon 1301 fire extinguisher is used, can employees evacuate within the specified time for that extinguisher?				
20.	Are appropriate fire extinguishers mounted within 75 feet of outside areas containing flammable liquids, and within 10 feet of any inside storage area for such materials?				
21.	Is the transfer/withdrawal of flammable or combustible liquids performed by trained personnel?				
22.	Are fire extinguishers mounted so that employees do not have to travel more than 75 feet for a class "A" fire or 50 feet for a class "B" fire?				
23.	Are employees trained in the use of fire extinguishers?				
24.	Are extinguishers free from obstructions or blockage?				
25.	Are all extinguishers serviced, maintained and tagged at intervals not to exceed one year?				
26.	Are all extinguishers fully charged and in their designated places?				
27.	Is a record maintained of required monthly checks of extinguishers?				
28.	Where sprinkler systems are permanently installed, are the nozzle heads directed or arranged so that water will not be sprayed into operating electrical switchboards and equipment?				
29.	Are "NO SMOKING" signs posted where appropriate in areas where flammable or combustible materials are used or stored?				





ID	Category	Response			Comment
		Yes	No	N/A	
30.	Are "NO SMOKING" signs posted on liquefied petroleum gas tanks?				
31.	Are "NO SMOKING" rules enforced in areas involving storage and use of flammable materials?				
32.	Are safety cans used for dispensing flammable or combustible liquids at a point of use?				
33.	Are all spills of flammable or combustible liquids cleaned up promptly?				
34.	Are storage tanks adequately vented to prevent the development of excessive vacuum or pressure as a result of filling, emptying, or atmosphere temperature changes?				
35.	Are storage tanks equipped with emergency venting that will relieve excessive internal pressure caused by fire exposure?				
36.	Are spare portable or butane tanks, which are used by industrial trucks stored in accord with regulations?				
<b>Z.</b>	<b>FIRE PROTECTION</b>				
1.	Do you have a fire prevention plan?				
2.	Does your plan describe the type of fire protection equipment and/or systems?				
3.	Have you established practices and procedures to control potential fire hazards and ignition sources?				
4.	Are employees aware of the fire hazards of the material and processes to which they are exposed?				
5.	Is your local fire department well acquainted with your facilities, location and specific hazards?				
6.	If you have a fire alarm system, is it tested at least annually?				
7.	If you have a fire alarm system, is it certified as required?				
8.	If you have interior standpipes and valves, are they inspected regularly?				
9.	If you have outside private fire hydrants, are they flushed at least once a year and on a routine preventive maintenance schedule?				
10.	Are fire doors and shutters in good operating condition?				
11.	Are fire doors and shutters unobstructed and protected against obstructions, including their counterweights?				
12.	Are fire door and shutter fusible links in place?				

ID	Category	Response			Comment
		Yes	No	N/A	
13.	Are automatic sprinkler system water control valves, air and water pressures checked weekly/periodically as required?				
14.	Is maintenance of automatic sprinkler system assigned to responsible persons or to a sprinkler contractor?				
15.	Are sprinkler heads protected by metal guards, when exposed to physical damage?				
16.	Is proper clearance maintained below sprinkler heads?				
17.	Are portable fire extinguishers provided in adequate number and type?				
18.	Are fire extinguishers mounted in readily accessible locations?				
19.	Are fire extinguishers recharged regularly and noted on the inspection tag?				
20.	Are employees periodically instructed in the use of extinguishers and fire protection procedures?				
<b>AA.</b>	<b>HAZARDOUS CHEMICAL EXPOSURES</b>				
1.	Are employees trained in the safe handling practices of hazardous chemicals such as acids, caustics, and the like?				
2.	Are employees aware of the potential hazards involving various chemicals stored or used in the workplace-- such as acids, bases, caustics, epoxies, and phenols?				
3.	Is employee exposure to chemicals kept within acceptable levels?				
4.	Are eye wash fountains and safety showers provided in areas where corrosive chemicals are handled?				
5.	Are all containers, such as vats and storage tanks labeled as to their contents-- e.g. "CAUSTICS"?				
6.	Are all employees required to use personal protective clothing and equipment when handling chemicals (i.e. gloves, eye protection, and respirators)?				
7.	Are flammable or toxic chemicals kept in closed containers when not in use?				
8.	Are chemical piping systems clearly marked as to their content?				
9.	Where corrosive liquids are frequently handled in open containers or drawn from storage vessels or pipelines, is adequate means readily available for neutralizing or disposing of spills or overflows properly and safely?				
10.	Have standard operating procedures been established and are they being followed when cleaning up chemical spills?				



ID	Category	Response			Comment
		Yes	No	N/A	
11.	Where needed for emergency use, are respirators stored in a convenient, clean and sanitary location?				
12.	Are respirators intended for emergency use adequate for the various uses for which they may be needed?				
13.	Are employees prohibited from eating in areas where hazardous chemicals are present?				
14.	Is personal protective equipment provided, used and maintained whenever necessary?				
15.	Are there written standard operating procedures for the selection and use of respirators where needed?				
16.	If you have a respirator protection program, are your employees instructed on the correct usage and limitations of the respirators?				
17.	Are the respirators NIOSH approved for this particular application?				
18.	Are they regularly inspected and cleaned sanitized and maintained?				
19.	If hazardous substances are used in your processes, do you have a medical or biological monitoring system in operation?				
20.	Are you familiar with the Threshold Limit Values or Permissible Exposure Limits of airborne contaminants and physical agents used in your workplace?				
21.	Have control procedures been instituted for hazardous materials, where appropriate, such as respirators, ventilation systems, handling practices, and the like?				
22.	Whenever possible, are hazardous substances handled in properly designed and exhausted booths or similar locations?				
23.	Do you use general dilution or local exhaust ventilation systems to control dusts, vapors, gases, fumes, smoke, solvents or mists which may be generated in your workplace?				
24.	c Is ventilation equipment provided for removal of contaminants from such operations as production grinding, buffing, spray painting, and/or vapor decreasing, and is it operating properly?				
25.	Do employees complain about dizziness, headaches, nausea, irritation, or other factors of discomfort when they use solvents or other chemicals?				
26.	Is there a dermatitis problem--do employees complain about skin dryness, irritation, or sensitization?				

ID	Category	Response			Comment
		Yes	No	N/A	
27.	Have you considered the use of an industrial hygienist or environmental health specialist to evaluate your operation?				
28.	If internal combustion engines are used, is carbon monoxide kept within acceptable levels?				
29.	Is vacuuming used, rather than blowing or sweeping dusts whenever possible for clean up?				
30.	Are materials, which give off toxic asphyxiant, suffocating or anesthetic fumes, stored in remote or isolated locations when not in use?				
<b>BB.</b>	<b>HAZARDOUS SUBSTANCES COMMUNICATION</b>				
1.	Is there a list of hazardous substances used in your workplace?				
2.	Is there a written hazard communication program dealing with Safety Data Sheets (SDS) labeling, and employee training?				
3.	Who is responsible for SDSs, container labeling, employee training?				
4.	Is each container for a hazardous substance (i.e. vats, bottles, storage tanks,) labeled with product identity and a hazard warning (communication of the specific health hazards and physical hazards)?				
5.	Is there a Material Safety Data Sheet readily available for each hazardous substance used?				
6.	How will you inform other employers whose employees share the same work area where the hazardous substances are used?				
7.	Is there an employee training program for hazardous substances?				
8.	Does this program include:				
9.	An explanation of what an SDS is and how to use and obtain one?				
10.	SDS contents for each hazardous substance or class of substances?				
11.	Explanation of "Right to Know"?				
12.	Identification of where employees can see the employer's written hazard communication program and where hazardous substances are present in their work area?				
13.	The physical and health hazards of substances in the work area, how to detect their presence, and specific protective measures to be used?				

ID	Category	Response			Comment
		Yes	No	N/A	
14.	Details of the hazard communication program, including how to use the labeling system and SDSs?				
15.	How employees will be informed of hazards of non-routine tasks, and hazards of unlabeled pipes?				
CC.	<b>ELECTRICAL</b>				
1.	Are your workplace electricians familiar with the Cal/OSHA Electrical Safety Orders?				
2.	Do you specify compliance with Cal/OSHA for all contract electrical work?				
3.	Are all employees required to report as soon as practicable any obvious hazard to life or property observed in connection with electrical equipment or lines?				
4.	Are employees instructed to make preliminary inspections and/or appropriate tests to determine what conditions exist before starting work on electrical equipment or lines?				
5.	When electrical equipment or lines are to be serviced, maintained or adjusted, are necessary switches opened, locked-out and tagged whenever possible?				
6.	Are portable electrical tools and equipment grounded or of the double insulated type?				
7.	Are electrical appliances such as vacuum cleaners, polishers, vending machines grounded?				
8.	Do extension cords being used have a grounding conductor?				
9.	Are multiple plug adapters prohibited?				
10.	Are ground-fault circuit interrupters installed on each temporary 15 or 20 ampere, 120 volt AC circuit at locations where construction, demolition, modifications, alterations or excavations are being performed?				
11.	Are all temporary circuits protected by suitable disconnecting switches or plug connectors at the junction with permanent wiring?				
12.	Is exposed wiring and cords with frayed or deteriorated insulation repaired or replaced promptly?				
13.	Are flexible cords and cables free of splices or taps?				
14.	Are clamps or other securing means provided on flexible cords or cables at plugs, receptacles, tools, and equipment and is the cord jacket securely held in place?				



ID	Category	Response			Comment
		Yes	No	N/A	
15.	Are all cord, cable and raceway connections intact and secure?				
16.	In wet or damp locations, are electrical tools and equipment appropriate for the use or location or otherwise protected?				
17.	Is the location of electrical power lines and cables (overhead, underground, underfloor, other side of walls) determined before digging, drilling or similar work is begun?				
18.	Are metal measuring tapes, ropes, handlines or similar devices with metallic thread woven into the fabric prohibited where they could come in contact with energized parts of equipment or circuit conductors?				
19.	Is the use of metal ladders prohibited in area where the ladder or the person using the ladder could come in contact with energized parts of equipment, fixtures or circuit conductors?				
20.	Are all disconnecting switches and circuit breakers labeled to indicate their use or equipment served?				
21.	Are disconnecting means always opened before fuses are replaced?				
22.	Do all interior wiring systems include provisions for grounding metal parts of electrical raceways, equipment and enclosures?				
23.	Are all electrical raceways and enclosures securely fastened in place?				
24.	Are all energized parts of electrical circuits and equipment guarded against accidental contact by approved cabinets or enclosures?				
25.	Is sufficient access and working space provided and maintained about all electrical equipment to permit ready and safe operations and maintenance?				
26.	Are all unused openings (including conduit knockouts) in electrical enclosures and fittings closed with appropriate covers, plugs or plates?				
27.	Are electrical enclosures such as switches, receptacles, junction boxes, etc., provided with tight-fitting covers or plates?				
28.	Are disconnecting switches for electrical motors in excess of two horsepower, capable of opening the circuit when the motor is in a stalled condition, without exploding? (Switches must be horsepower rated equal to or in excess of the motor hp rating).				





ID	Category	Response			Comment
		Yes	No	N/A	
29.	Is low voltage protection provided in the control device of motors driving machines or equipment, which could cause probably injury from inadvertent starting?				
30.	Is each motor disconnecting switch or circuit breaker located within sight of the motor control device?				
31.	Is each motor located within sight of its controller or the controller disconnecting means capable of being locked in the open position or is a separate disconnecting means installed in the circuit within sight of the motor?				
32.	Is the controller for each motor in excess of two horsepower, rated in horsepower equal to or in excess of the rating of the motor it serves?				
33.	Are employees who regularly work on or around energized electrical equipment or lines instructed in the cardiopulmonary resuscitation (CPR) methods?				
34.	Are employees prohibited from working alone on energized lines or equipment over 600 volts?				
DD.	<b>NOISE</b>				
1.	Are there areas in the workplace where continuous noise levels exceed 85 dBA? (To determine maximum allowable levels for intermittent or impact noise, see Title 8, Section 5097.)				
2.	Are noise levels being measured using a sound level meter or an octave band analyzer and records being kept?				
3.	Have you tried isolating noisy machinery from the rest of your operation?				
4.	Have engineering controls been used to reduce excessive noise levels?				
5.	where engineering controls are determined not feasible, are administrative controls (i.e. worker rotation) being used to minimize individual employee exposure to noise?				
6.	Is there an ongoing preventive health program to educate employees in safe levels of noise and exposure, effects of noise on their health, and use of personal protection?				
7.	Is the training repeated annually for employees exposed to continuous noise above 85 dBA?				
8.	Have work areas where noise levels make voice communication between employees difficult been identified and posted?				



ID	Category	Response			Comment
		Yes	No	N/A	
9.	Is approved hearing protective equipment (noise attenuating devices) available to every employee working in areas where continuous noise levels exceed 85 dBA?				
10.	If you use ear protectors, are employees properly fitted and instructed in their use and care?				
11.	Are employees exposed to continuous noise above 85 dBA given periodic audiometric testing to ensure that you have an effective hearing protection system?				
<b>EE.</b>	<b>FUELING</b>				
1.	Is it prohibited to fuel an internal combustion engine with a flammable liquid while the engine is running?				
2.	Are fueling operations done in such a manner that likelihood of spillage will be minimal?				
3.	When spillage occurs during fueling operations, is the spilled fuel cleaned up completely, evaporated, or other measures taken to control vapors before restarting the engine?				
4.	Are fuel tank caps replaced and secured before starting the engine?				
5.	In fueling operations is there always metal contact between the container and fuel tank?				
6.	Are fueling hoses of a type designed to handle the specific type of fuel?				
7.	Is it prohibited to handle or transfer gasoline in open containers?				
8.	Are open lights, open flames, or sparking or arcing equipment prohibited near fueling or transfer of fuel operations?				
9.	Is smoking prohibited in the vicinity of fueling operations?				
10.	Are fueling operations prohibited in building or other enclosed areas that are not specifically ventilated for this purpose?				
11.	Where fueling or transfer of fuel is done through a gravity flow system, are the nozzles of the self-closing type?				
<b>FF.</b>	<b>IDENTIFICATION OF PIPING SYSTEMS</b>				
1.	When non-potable water is piped through a facility, are outlets or taps posted to alert employees that it is unsafe and not to be used for drinking, washing or other personal use?				
2.	When hazardous substances are transported through above ground piping, is each pipeline identified at points where confusion could introduce hazards to employees?				



ID	Category	Response			Comment
		Yes	No	N/A	
3.	When pipelines are identified by color painting, are all visible parts of the line so identified?				
4.	When pipelines are identified by color painted bands or tapes, are the bands or tapes located at reasonable intervals and at each outlet, valve or connection?				
5.	When pipelines are identified by color, is the color code posted at all locations where confusion could introduce hazards to employees?				
6.	When the contents of pipelines are identified by name or name abbreviation, is the information readily visible on the pipe near each valve or outlet?				
7.	When pipelines carrying hazardous substances are identified by tags, are the tags constructed of durable materials, the message carried clearly and permanently distinguishable and are tags installed at each valve or outlet?				
8.	When pipelines are heated by electricity, steam or other external source, are suitable warning signs or tags placed at unions, valves, or other serviceable parts of the system?				
<b>GG.</b>	<b>MATERIAL HANDLING</b>				
1.	Is there safe clearance for equipment through aisles and doorways?				
2.	Are aisleways designated, permanently marked, and kept clear to allow unhindered passage?				
3.	Are motorized vehicles and mechanized equipment inspected daily or prior to use?				
4.	Are vehicles shut off and brakes set prior to loading or unloading?				
5.	Are containers or combustibles or flammables, when stacked while being moved, always separated by dunnage sufficient to provide stability?				
6.	Are dock boards (bridge plates) used when loading or unloading operations are taking place between vehicles and docks?				
7.	Are trucks and trailers secured from movement during loading and unloading operations?				
8.	Are dock plates and loading ramps constructed and maintained with sufficient strength to support imposed loading?				
9.	Are hand trucks maintained in safe operating condition?				
10.	Are chutes equipped with sideboards of sufficient height to prevent the materials being handled from falling off?				



ID	Category	Response			Comment
		Yes	No	N/A	
11.	Are chutes and gravity roller sections firmly placed or secured to prevent displacement?				
12.	At the delivery end of rollers or chutes, are provisions made to brake the movement of the handled materials.				
13.	Are pallets usually inspected before being loaded or moved?				
14.	Are hooks with safety latches or other arrangements used when hoisting materials so that slings or load attachments won't accidentally slip off the hoist hooks?				
15.	Are securing chains, ropes, chockers or slings adequate for the job to be performed?				
16.	When hoisting material or equipment, are provisions made to assure no one will be passing under the suspended loads?				
17.	Are Material Safety Data Sheets available to employees handling hazardous substances?				
<b>HH.</b>	<b>TRANSPORTING EMPLOYEES &amp; MATERIALS</b>				
1.	Do employees who operate vehicles on public thoroughfares have valid operator's licenses?				
2.	When seven or more employees are regularly transported in a van, bus or truck, is the operator's license appropriate for the class of vehicle being driven?				
3.	Is each van, bus or truck used regularly to transport employees, equipped with an adequate number of seats?				
4.	When employees are transported by truck, are provision provided to prevent their falling from the vehicle?				
5.	Are vehicles used to transport employees, equipped with lamps, brakes, horns, mirrors, windshields and turn signals in good repair?				
6.	Are transport vehicles provided with handrails, steps, stirrups or similar devices, so placed and arranged that employees can safely mount or dismount?				
7.	Are employee transport vehicles equipped at all times with at least two reflective type flares?				
8.	Is a full charged fire extinguisher, in good condition, with at least 4 B:C rating maintained in each employee transport vehicle?				

ID	Category	Response			Comment
		Yes	No	N/A	
9.	When cutting tools with sharp edges are carried in passenger compartments of employee transport vehicles, are they placed in closed boxes or containers which are secured in place?				
10.	Are employees prohibited from riding on top of any load, which can shift, topple, or otherwise become unstable?				
<b>II.</b>	<b>CONTROL OF HARMFUL SUBSTANCES BY VENTILATION</b>				
1.	Is the volume and velocity of air in each exhaust system sufficient to gather the dusts, fumes, mists, vapors or gases to be controlled, and to convey them to a suitable point of disposal?				
2.	Are exhaust inlets, ducts and plenums designed, constructed, and supported to prevent collapse or failure of any part of the system?				
3.	Are clean-out ports or doors provided at intervals not to exceed 12 feet in all horizontal runs of exhaust ducts?				
4.	Where two or more different type of operations are being controlled through the same exhaust system, will the combination of substances being controlled, constitute a fire, explosion or chemical reaction hazard in the duct?				
5.	Is adequate makeup air provided to areas where exhaust systems are operating?				
6.	Is the intake for makeup air located so that only clean, fresh air, which is free of contaminants, will enter the work environment?				
7.	Where two or more ventilation systems are serving a work area, is their operation such that one will not offset the functions of the other?				
<b>JJ.</b>	<b>SANITIZING EQUIPMENT &amp; CLOTHING</b>				
1.	Is personal protective clothing or equipment, that employees are required to wear or use, of a type capable of being easily cleaned and disinfected?				
2.	Are employees prohibited from interchanging personal protective clothing or equipment, unless it has been properly cleaned?				
3.	Are machines and equipment, which processes, handle or apply materials that could be injurious to employees, cleaned and/or decontaminated before being overhauled or placed in storage?				
4.	Are employees prohibited from smoking or eating in any area where contaminants are present that could be injurious if ingested?				

ID	Category	Response			Comment
		Yes	No	N/A	
5.	When employees are required to change from street clothing into protective clothing, is a clean changeroom with separate storage facility for street and protective clothing provided?				
6.	Are employees required to shower and wash their hair as soon as possible after a known contact has occurred with a carcinogen?				
7.	When equipment, materials, or other items are taken into or removed from a carcinogen regulated area, is it done in a manner that will not contaminate non-regulated areas or the external environment?				
<b>KK.</b>	<b>TIRE INFLATION</b>				
1.	Where tires are mounted and/or inflated on drop center wheels is a safe practice procedure posted and enforced?				
2.	Where tires are mounted and/or inflated on wheels with split rims and/or retainer rings is a safe practice procedure posted and enforced?				
3.	Does each tire inflation hose have a clip-on chuck with at least 24 inches of hose between the chuck and an inline hand valve and gauge?				
4.	Does the tire inflation control valve automatically shut off the airflow when the valve is released?				
5.	Is a tire restraining device such as a cage, rack or other effective means used while inflating tires mounted on split rims, or rims using retainer rings?				
6.	Are employees strictly forbidden from taking a position directly over or in front of a tire while it's being inflated?				
<b>LL.</b>	<b>EMERGENCY ACTION PLAN</b>				
1.	Are you required to have an emergency action plan?				
2.	Does the emergency action plan comply with requirements of T8CCR 3220(a)?				
3.	Have emergency escape procedures and routes been developed and communicated to all employees?				
4.	Do employees, who remain to operate critical plant operations before they evacuate, know the proper procedures?				
5.	Is the employee alarm system that provides a warning for emergency action recognizable and perceptible above ambient conditions?				
6.	Are alarm systems properly maintained and tested regularly?				





ID	Category	Response			Comment
		Yes	No	N/A	
7.	Is the emergency action plan reviewed and revised periodically?				
8.	Do employees now their responsibilities:				
9.	For reporting emergencies?				
10.	During an emergency?				
11.	For conducting rescue and medical duties?				
<b>MM.</b>	<b>INFECTION CONTROL</b>				
1.	Are employees potentially exposed to infectious agents in body fluids?				
2.	Have occasions of potential occupational exposure been identified and documented?				
3.	Has a training and information program been provided for employees exposed to or potentially exposed to blood and/or body fluids?				
4.	Have infection control procedures been instituted where appropriate, such as ventilation, universal precautions, workplace practices, and personal protective equipment?				
5.	Are employees aware of specific workplace practices to follow when appropriate? (Hand washing, handling sharp instruments, handling of laundry, disposal of contaminated materials, reusable equipment.)				
6.	Is personal protective equipment provided to employees, and in all appropriate locations?				
7.	Is the necessary equipment (i.e. mouthpieces, resuscitation bags, and other ventilation devices) provided for administering mouth-to-mouth resuscitation on potentially infected patients?				
8.	Are facilities/equipment to comply with workplace practices available, such as hand-washing sinks, biohazard tags and labels, needle containers, detergents/disinfectants to clean up spills?				
9.	Are all equipment and environmental and working surfaces cleaned and disinfected after contact with blood or potentially infectious materials?				
10.	Is infectious waste placed in closable, leak proof containers, bags or puncture-resistant holders with proper labels?				
11.	Has medical surveillance including HBV evaluation, antibody testing and vaccination been made available to potentially exposed employees?				
12.	Training on universal precautions?				



ID	Category	Response			Comment
		Yes	No	N/A	
13.	Training on personal protective equipment?				
14.	Training on workplace practices, which should include blood drawing, room cleaning, laundry handling, cleanup of blood spills?				
15.	Training on needlestick exposure/management?				
16.	Hepatitis B vaccinations?				
<b>NN.</b>	<b>ERGONOMICS</b>				
1.	Can the work be performed without eyestrain or glare to the employees?				
2.	Does the task require prolonged raising of the arms?				
3.	Do the neck and shoulders have to be stooped to view the task?				
4.	Are there pressure points on any parts of the body (wrists, forearms, back of thighs)?				
5.	Can the work be done using the larger muscles of the body?				
6.	Can the work be done without twisting or overly bending the lower back?				
7.	Are there sufficient rest breaks, in addition to the regular rest breaks, to relieve stress from repetitive-motion tasks?				
8.	Are tools, instruments and machinery shaped, positioned and handled so that tasks can be performed comfortably?				
9.	Are all pieces of furniture adjusted, positioned and arranged to minimize strain on all parts of the body?				
<b>OO.</b>	<b>VENTILATION FOR INDOOR AIR QUALITY</b>				
1.	Does your HVAC system provide at least the quantity of outdoor air required by the State Building Standards Code, Title 24, Part 2 at the time the building was constructed?				
2.	Is the HVAC system inspected at least annually, and problems corrected?				
3.	Are inspection records retained for at least 5 years?				
<b>PP.</b>	<b>CRANE CHECKLIST</b>				
1.	Are the cranes visually inspected for defective components prior to the beginning of any work shift?				
2.	Are all electrically operated cranes effectively grounded?				
3.	Is a crane preventive maintenance program established?				
4.	Is the load chart clearly visible to the operator?				
5.	Are operating controls clearly identified?				



ID	Category	Response			Comment
		Yes	No	N/A	
6.	Is a fire extinguisher provided at the operator's station?				
7.	Is the rated capacity visibly marked on each crane?				
8.	Is an audible warning device mounted on each crane?				
9.	Is sufficient illumination provided for the operator to perform the work safely?				
10.	Are cranes of such design, that the boom could fall over backward, equipped with boom stops?				
11.	Does each crane have a certificate indicating that required testing and examinations have been performed?				
12.	Are crane inspection and maintenance records maintained and available for inspection?				

(Cal/OSHA)



## **APPENDIX E**

### **PG&E ER Contractor Reporting Guidance**



## Environmental Remediation Contractor Event Reporting Guidance

**Summary** This is guidance for contractor reporting of Safety and Land & Environmental events to PG&E Environmental Remediation (ER) personnel. This guidance provides definitions for contractor use. Contractors are encouraged to report all events to PG&E for broader project application of lessons learned.

**NOTE: Reporting events to PG&E personnel DOES NOT supersede required external agency reporting. The ER contractor is responsible for appropriately reporting all incidents to local, state, and federal agencies as required by law.**

**Proactive Events** Proactive Events should be reported and shared among project teams, and reported on a monthly basis to PG&E (refer to the “Monthly Reporting” section of this guidance document for further information).

**BEST PRACTICE:** A work activity, procedure, or behavior that represents a consensus "best in class" approach for controlling a hazard, or goes above and beyond minimum expectations. Note: Best practices communicated to PG&E will be shared across Remediation project teams.

**OBSERVATION:** A safety hazard or compliance issue that is identified and addressed proactively, before it causes an incident or near hit.

**EXTERNAL REGULATORY INSPECTION:** An event in which an outside agency visits a project location to conduct a formal or informal inspection or audit. Note: These events trigger certain initial notifications – refer to the “Initial Notification Procedure” section of this guidance document for further information.

**Land & Environment Incidents (Compliance Incidents)**

**Land & Environment Incidents:** A compliance incident that results in the following:

- **Notice of Violation (NOV)** – A regulator’s decree of a failure to comply.
- **Non-Conformance (NC)** – Failure to comply with external compliance requirement without a regulator having issued a formal NOV. These compliance failures may be identified through the Line of Business (LOB) internal monitoring systems (e.g., QA/QC, Self-Assessments, Inspections, Testing) or by an external party.
- **Self-Report:** Occurs when PG&E reports a NC to an external Agency that is not already included in routine reports. This report can be a result of either an external legal or regulatory obligation or of a voluntary PG&E decision.

- Incidents should be designated by **Severity** – High, Medium, or Low impact
- Review the [Shared Services Incident Reporting Matrix](#) to determine the severity.





## Environmental Remediation Contractor Event Reporting Guidance

**Spill/Release Definitions** **SPILL/RELEASE:** Any release of a material/substance that was not permitted or intentional, regardless of whether it triggers agency reporting or results in agency written notice of violation. This includes odor incidents. Any release that went where it was not intended or expected to go is included in this metric (e.g., releases to asphalt or concrete surface, or to a secondary containment, if unplanned/unintentional, would be considered releases). The three levels of action to be measured in this metric include:

- **Minor Release:** A release of a material that does not extend beyond the boundaries of the project site, does not require an emergency agency response (agency notification may be required depending on jurisdiction), does not result in immediate or observable injury, and is cleaned up or mitigated within 8 hours of release termination.
- **Moderate Release:** A release of material that extends beyond the boundary of the facility, but does not require an emergency agency response (agency notification may be required depending on jurisdiction), does not result in immediate or observable injury, and is cleaned up or mitigated within 8 hours of release termination. For purposes of air releases, this includes situations where site operations are fully or partially shut down for less than 24 hours.
- **Major Release:** A release of material that may or may not extend beyond the boundary of the property, but results in injury or significant exposure, or requires outside emergency response assistance, or cannot be terminated or cleaned up within 8 hours of release discovery, or results in shutdown of all site operations for more than 24 hours.

**Safety Event Definitions** **NEAR HIT:** An unplanned event that could have resulted in an incident, but fortunately no consequences resulted because of favorable circumstances or “luck”.

- **Severity Classification:** (Link: [Safety Observations Severity Matrix](#)).
  - **Low:** High energy is not present and the control is inadequate.
  - **Medium:** High energy is not present and the control is absent.
  - **High:** High energy is present and the direct control is inadequate.
  - **Life Threatening:** High energy is present and the direct control is absent.

**NOISE/VIBRATION INCIDENT:** Any event that results in the public or agency responding to noise or vibration issues related to work on a PG&E Project. The three levels of action to be measured in these metrics include:

- **Complaint:** Any visit or contact by an agency or the public to notify the contractor or PG&E that a noise or vibration issue has been identified.
- **Shutdown:** Any noise or vibration event that would result in a shutdown of all site operations for more than 24 hours.
- **Damage:** Any noise or vibration incident that results in operational disturbance or nuisance to the public or damage to structures from work on a PG&E Project. This would include any monetary fines or payments for loss of business.

**SAFETY INCIDENT:** Any event that results in an injury, illness, or property damage. The five levels of action to be measured in this metric include:

- **Property Damage:** An event that results in any incidental property damage (not including utility strike related incidents) incurred due to work on a PG&E Project.



## Environmental Remediation Contractor Event Reporting Guidance

- **Minor Safety Incident:** A safety incident that occurs on a PG&E Project; however, does not result in first aid or medical treatment. This would include incidents such as minor electrical shocks, pinched hands/fingers, slip/trip/fall without injury, etc.
- **First Aid:** An incident that results in a first aid injury related to work on a PG&E Project. This would include any onsite first aid care or a visit to an urgent care facility where only first aid is administered.
- **OSHA Recordable:** An incident that results in an OSHA recordable related to work on a PG&E Project. These can be either Lost Work Day (LWD) incidents where personnel miss one or more days from work, Restricted Duty (RD) incidents where personnel have work restrictions put in place, or Medical Treatment (MT) incidents where personnel receive medical treatment beyond first aid, meeting the definitions under OSHA Recordkeeping regulations.
- **Fatality:** An incident that results in any fatality related to work on a PG&E Project.

**UTILITY STRIKE:** Contact to any underground or aboveground utility that results in damage (any impact or exposure that results in the need to repair) or other consequence. This includes, but is not limited to, electrical lines, cable boxes, manholes, ducts, gas pipelines, water pipelines, irrigation/sprinkler lines, communications cable, sanitary and storm sewers, hazardous materials pipelines, and associated substructures. **The four levels of action to be measured in this metric include:**

- **Category 1 Strike:** Utility strike not involving electricity, gas, or hazardous materials that result in no injury or death; results in customer outage of no more than 24-hours; or causes property/equipment damage less than \$50K.
- **Category 2 Strike:** Utility strike involving electricity, gas, or hazardous materials that result in no injury or death; results in customer outage less than 24-hours; causes property/equipment damage less than \$50K; or results in no fire, release or explosion requiring outside emergency response.
- **Category 3 Strike:** Utility strikes of any kind that result in property/equipment damage exceeding \$50K, or customer outage greater than 24-hours, but does not result in injury or death; hazardous materials release requiring agency notification; or release, fire or explosion requiring outside emergency response.
- **Category 4 Strike:** Utility strike of any kind that results in injury or death; hazardous materials release requiring agency notification; or release, fire or explosion requiring outside emergency response.

**NOTE:** If a line is encountered but is not damaged, or if an abandoned line is damaged and does not require repair, then this would be a NEAR HIT. If damage and repairs are planned as part of the work, and occur with the authorization of the owner/operator of a line, we would not consider this a safety incident or near hit.

**MOTOR VEHICLE:** Any incident involving a vehicle that results in unintentional damage to person(s) or property. **The two levels of action to be measured in this metric include:**

- **Minor Vehicle Incident:** A vehicle incident occurring either on-site or on public roadways that results in property or equipment damage less than \$5,000, no one involved receives medical treatment away from the scene of the incident, and no vehicles are towed from the scene.
- **Major Vehicle Incident:** A vehicle incident occurring either on-site or on public roadways that results property or equipment damage equal to or greater than \$5,000, anyone involved receives medical treatment away from the scene of the incident, or the vehicle is towed from the scene.



## Environmental Remediation Contractor Event Reporting Guidance

### Incidents Reporting

Please use the [Event Reporting Matrix](#) as a guide and the [Event Reporting Template](#) as a tool.

*\*See the 'Attachments' section (left column) of the PDF to download the Word version of the reporting template.*

**NOTE: Reporting events to PG&E personnel DOES NOT supersede required external agency reporting. The ER contractor is responsible for appropriately reporting all incidents to local, state and federal agencies as required by law.**

### Land & Environment Incident (Compliance Incident) Notification Procedure

Upon identification or notification of a potential or actual non-conformance (NC), or receipt of a citation, or Notice of Violation (NOV), the contractor should verbally notify the PG&E PM immediately (within 2 hours). For all potential or actual NCs, NOVs, citations, the following information should be submitted via email to the PG&E PM, PG&E Manager, the ER Compliance Lead, and Safety & Compliance Mailbox within 24 hours:

- Project name/event location
- Date, time, and duration of the event (identified/reported)
- Contractors/agencies/parties Involved
- Event description
- Applicable requirement(s) potentially or actually violated
- Cause of NC/NOV
- Scope/scale of the problem (e.g., isolated one-time event, widespread, unknown magnitude)
- Initial response or corrective actions
- Chronology and timeline of events leading up to the NC/NOV

<b>ER Safety and Compliance Lead</b>
<b>Lauren Baeta</b>
<a href="mailto:l6b7@pge.com">l6b7@pge.com</a>
925-655-7002 (Mobile)

### Safety Event Notification Procedure

Upon a Safety Incident or Near Hit (high or life threat) occurring, the contractor should verbally notify the PG&E PM immediately (within 2 hours). The following information should be submitted via email to the PG&E PM, ER's Safety and Compliance Lead, and the ER Safety & Compliance Mailbox within 24 hours:

- Project name/event location
- Date, time, and duration of the event
- Contractors/parties Involved
- Event description
- Initial response or corrective actions

NOTE: This initial notification process is not required for proactive observations, best practices, and/or near hits (low or medium) unless requested by PG&E PM's request. Verbal notification within 2 hours for external regulatory inspections is required, but not follow-up email notification.

For California or Federal Occupational Safety and Health Administration (OSHA) inspections:

- Ask to see the inspector's identification / credentials
- Request an opening meeting/conference
- Immediately notify the PG&E PM, PG&E Safety & Compliance Principal, and Consultant H&S Lead(s) so they have the opportunity to participate in the opening conference and can provide further guidance and consultation.



## Environmental Remediation Contractor Event Reporting Guidance

**Motor Vehicle Incident** Upon a Motor Vehicle Incident (MVI) while performing business for PG&E, the contractors must fill out all appropriate sections of the [Contractor Motor Vehicle Incident Collection Form](#) and submit to PG&E PM, ER's Safety and Compliance Lead, and the ER Safety & Compliance Mailbox within 24 hours of the incident.

---

**Root Cause Analysis** For certain types of events as outlined below, the contractor is expected to perform a Root Cause Analysis (RCA) to evaluate the causal and contributing factors to the event and develop corrective/preventive actions.

For major incidents such as Level 1 Sanction, Major Release, Noise/Vibration Damage, Category 3 or 4 Utility Strike, Major Motor Vehicle Incident, or any safety event resulting in offsite emergency care, a formal RCA is required. The RCA should be recorded in a contractor specific RCA form. RCAs are to be submitted to the PG&E Project Manager and Contractor Safety Lead within 5 business days.

For all other incidents and near hits, RCAs should be summarized in the monthly event report. Upon request by PG&E, a formal RCA form should also be submitted to the PG&E Project Manager and Contractor Safety Lead along with monthly reporting.

A formal RCA is not required for proactive observations, best practices, or external regulatory inspections; however, the PG&E Project Manager and Contractor Safety Lead can request an RCA, based on event severity and conditions. Whether or not a formal RCA is prepared, follow-up should occur for all proactive observations to determine causes and document any corrective/preventative actions.

---

**Monthly Reporting** On a monthly basis, a point person from each AP/PMO firm will update the ER HSE Tool. The HSE Tool will capture all safety and compliance metrics, as well as monthly agency inspections for each AP/PMO firm. The HSE Tool has the capability to create roll-up tables and graphs for monthly, quarterly, and annual trending. In addition to incidents and near hits, each firm will also be responsible for reporting other safety observations, best practices, and monthly agency inspections into the Tool. Agency inspection reports must provide the project name, inspection date, agency name, inspector name, a description of the activities observed, and a description of any corrective actions or recommendations, if applicable.

---

# PG&E Environmental Remediation Event Reporting Process



## Incidents, Near Hits<sup>(high/life threat)</sup>, and OSHA Inspections

PG&E PM \_\_\_\_\_ Consultant/Contractor PM \_\_\_\_\_  
Phone Number\_(\_\_\_\_)\_\_\_\_\_ Phone Number\_(\_\_\_\_)\_\_\_\_\_

PG&E H&S Lead \_\_\_\_\_ Consultant/Contractor H&S Lead \_\_\_\_\_  
Phone Number\_\_\_\_\_ Phone Number\_\_\_\_\_

### Immediate

- Stop Work
- Stabilize the situation
  - This could include getting medical attention for any injured or ill persons, evacuating the area, notifying site owner of damage, etc.
- Discuss with those involved & correct any immediate hazard(s)

### Within 2 hours

- Verbally notify the PG&E Project Manager
- For OSHA inspections, verbally notify PG&E ER Safety & Compliance Lead (Lauren Baeta 925-655-7002)

### Within 24 hours

- Submit Email notification to:
  - PG&E Project Manager
  - PG&E ER Safety & Compliance Lead
  - Consultant / contractor project manager(s) and H&S lead
  - ER Safety & Compliance Mailbox
- The e-mail should include: project name, event location; date / time & duration of event; contractors / parties involved; brief event description; and initial response or corrective actions.
- For MVIs, submit the [Contractor Motor Vehicle Incident Collection Form](#).

### Within 5 days

- Complete investigation to determine root causes and develop corrective and preventive actions, as applicable
- Submit a formal root cause analysis (RCA) to PG&E Project Manager for all major incidents as defined in the PG&E ER Event Reporting Guidance.
- An RCA may also be recommended for other selected incidents and near misses at PG&E and/or consultant / contractor discretion.

### Monthly

- Prime consultant report all safety incidents, near hits, and OSHA inspections to PG&E via online HSE Tool, by the 10th of each month.

## Observations, Best Practices, Regulatory (non-OSHA) Inspections, Near Hits<sup>(low/med)</sup>

### Within 24 hours

- Communicate relevant observations/best practices/near hits at least daily to:
  - All on-site personnel during tailgate meetings
  - As warranted or upon request, to PG&E Project Manager

### Monthly

- Prime consultant report all observations, safe behaviors and regulatory inspections to PG&E via online HSE Tool, by the 10th of each month.

# Safety Observations Severity Matrix



Together, Building a Better California

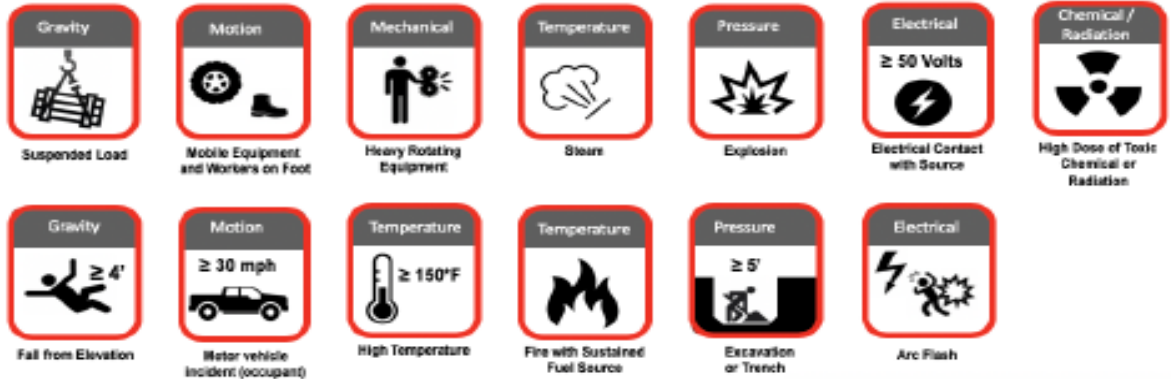

**Step 1: Determine if At Risk condition and High Energy is present**

**Was high energy present?**

No

Yes

**Step 2: Determine status of control**

**Status of Control:**

	No	Yes
LOW <i>(Control inadequate)</i>		HIGH <i>(Direct Control inadequate/deficient)</i>
MEDIUM <i>(Control absent)</i>		LIFE THREAT <i>(Direct Control absent)</i>



# Safety Observations Severity Matrix



Together, Building  
a Better California

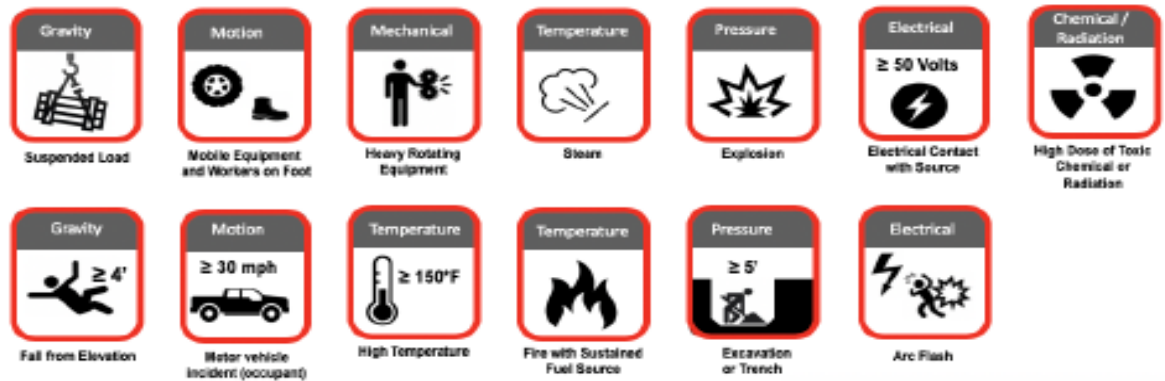

**High Energy** - Any electrical, mechanical, hydraulic, pneumatic, chemical, nuclear, thermal, gravitational, or other energy that can harm personnel or the public.

**\*\* “High Energy” does NOT only refer to electricity\*\***

# Safety Observations Severity Matrix



Together, Building  
a Better California

Electrical	Gravity	Motion
<ul style="list-style-type: none"> <li>• Arc flash</li> <li>• Boom strike with an energized line</li> <li>• Worker contacting an electrical source containing a lethal amount of energy</li> </ul>	<ul style="list-style-type: none"> <li>• Crane, Backhoe, other equipment tip-over / rollover</li> <li>• Suspended load</li> <li>• Fall into open trench/excavation of significant depth (over 4 ft)</li> <li>• Fall from a height of 4 ft or higher</li> <li>• Dropped tool/object of sufficient mass</li> </ul>	<ul style="list-style-type: none"> <li>• Mobile equipment in motion with a worker on foot</li> <li>• Mobile equipment of sufficient mass moving at a sufficient speed</li> <li>• Helicopter in motion / flight</li> </ul>

Mechanical	Pressure	Thermal
<ul style="list-style-type: none"> <li>• Rotating equipment</li> <li>• Percussive tools</li> <li>• Powered hand tools</li> <li>• Drive belts</li> </ul>	<ul style="list-style-type: none"> <li>• Trench or excavation</li> <li>• Gas Transmission Line (uncontrolled release of pressure above 60 psig)</li> <li>• Explosion</li> </ul>	<ul style="list-style-type: none"> <li>• Fire with a sustained fuel source</li> <li>• Welding</li> <li>• Steam</li> </ul>

Chemical	Biological	Noise
<ul style="list-style-type: none"> <li>• Flammable vapors</li> <li>• Carcinogens or other toxic compounds</li> <li>• Corrosives</li> <li>• Oxygen-deficient atmospheres</li> <li>• Dust</li> <li>• Gases</li> </ul>	<ul style="list-style-type: none"> <li>• Animal or insect attack of sufficient severity</li> </ul>	<ul style="list-style-type: none"> <li>• Equipment, impact, or high-pressure release noise of sufficient harmful decibels</li> </ul>

# Safety Observations Severity Matrix



Together, Building a Better California

## SafetyNet Forms for high SIF potential

(Please note: These are only some of the possible forms available)

<u>Vehicle Safety</u>	<u>Electrical Contact</u>	<u>Powered Tools</u>	<u>Working at Heights</u>
Driver Ride-Along	Live Electrical Work	Powered Tool Use	Climb Work
Utility Task Vehicle	Rubber Glove	Mobile Equipment use	Suspended Loads/Rigging
Powered Industrial Trucks	Grounding	Chainsaw use	Work at Heights
Heavy Equipment/Commercial Vehicles		Hand and Powered Tools	Excavation/Dig in

Would at-risk behavior lead to airborne transmission of virus?

No

- No Surface Sanitation
- Temperature Not Taken
- No Cleaning Products

Yes

- No Mask
- Not Staying home when sick
- 2+ per vehicle
- Not Social distancing

## COVID-19

LOW	HIGH Do Not Use
MEDIUM	LIFE THREAT Do Not Use

Time (Hr/Day) spent in Awkward Position/ Repetitive Movement

## ERGO

LOW	HIGH Do Not Use
MEDIUM	LIFE THREAT Do Not Use

1-2Hr/Day or Non-repetitive Movement

2+Hr/Day or Repetitive\* Movement

\*A repetitive motion is a motion that occurs every few seconds (a cycle time less than 30 seconds) with little or no variation. A repetitive motion is considered highly repetitive if it is performed for more than two hours total per day and/or shift

## **APPENDIX F**

### **PG&E ER Contractor Event Reporting – Project Quick Reference**



# QUICK REFERENCE GUIDE

## Safety & Compliance Event Reporting

Version 2 – November 2016

**Audience:**

PG&E Environmental Remediation Department Employees, Consultant / contractor site supervisors and field team leads, consultant / contractor project managers

**Reference Documents:**

PG&E Environmental Remediation (ER) Contractor Reporting Guidance, Revision 4, November 14, 2016

**Summary**

This Quick Reference Guide summarizes key actions to be taken to ensure timely notification and reporting of safety and compliance events, as defined in PG&E’s Environmental Remediation (ER) Contractor Reporting Guidance.

**What You Need to Know**

All safety and compliance events should be reported, including:

- Incidents, resulting in injury, illness, property damage, fire, unintentional release of a material or substance, non-compliance, or public complaint.
- Near hits, where an unplanned event could have resulted in an incident, but fortunately no consequences resulted because of favorable circumstances or “luck”.
- Observations of hazards or other safety / compliance issues that are addressed proactively before they cause incidents or near hits.
- Best practices, involving an activity, procedure, or behavior that represents a "best in class" approach for controlling a hazard, or goes above and beyond expectations.
- External regulatory inspections, where an outside agency visits a project location to conduct a formal or informal inspection or audit.

**Safety & Compliance Event Reporting – Incidents and Near Hits**

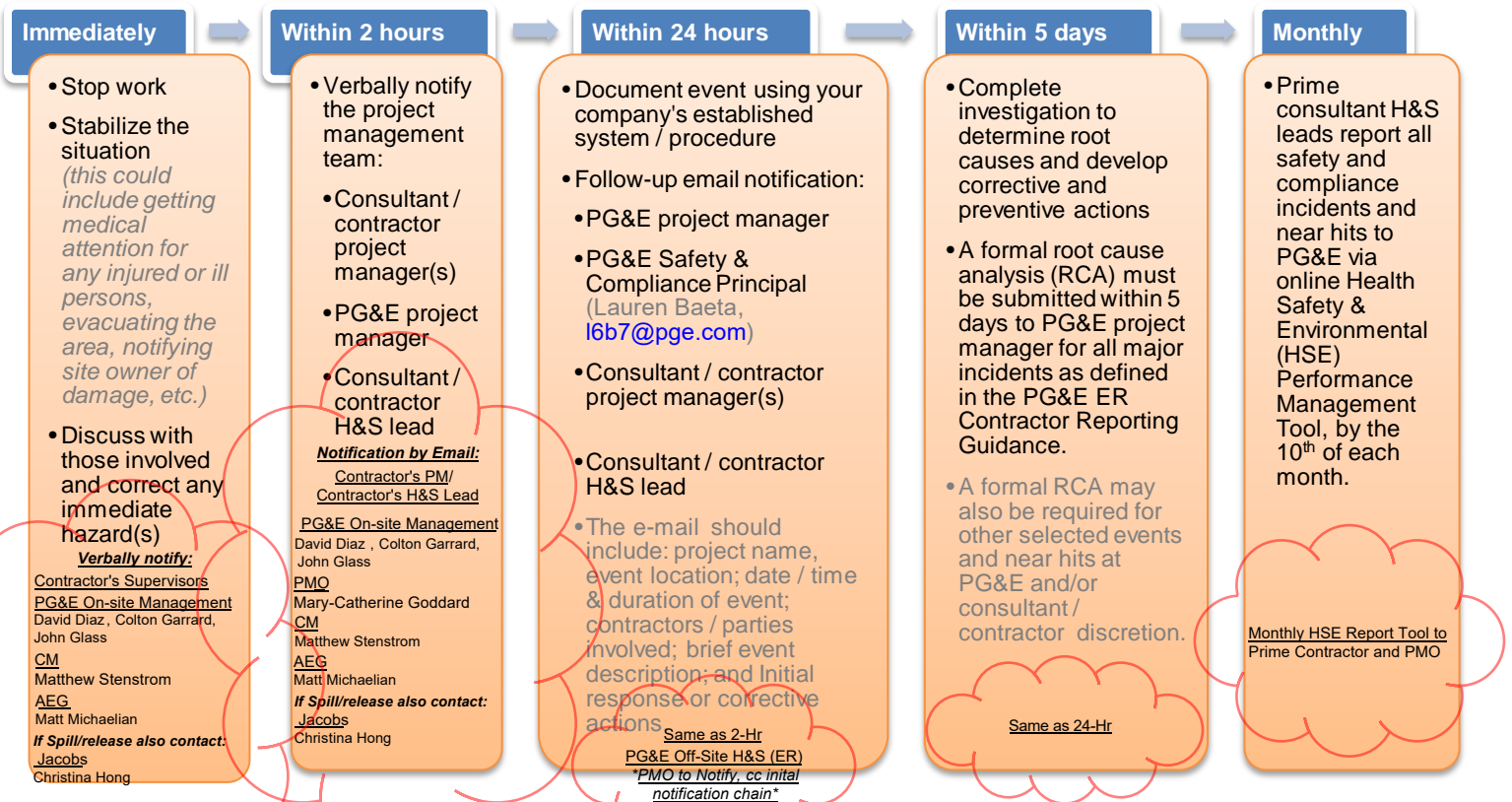

## **APPENDIX G**

### **PG&E ER Contractors Observation Guidelines**



## Contractor Observation and Coaching Guidelines

### Contractor Observations are intended to:

- Provide an opportunity to observe, learn, and coach contractors on safe work practices
- Identify organizational & Human Performance issues found in the workplace
- Provide insight into the behaviors, tools, resources, and barriers encountered on the job
- Foster two-way communication between management, employees, grassroots members, supervisors, safety specialists and contractors
- Evaluate the effectiveness of our expectations & communicate our expectations of performance standards

### What to Observe for:

- Identify issues before they cause errors in the workplace
- Identify minor recoverable actions, then coach on safe and effective work practices and expectations
- Barriers encountered that affect the execution of a task
- Good behaviors and best practices that we need to learn from

### Coaching:

- When you see something that doesn't meet CalOSHA Title 8 standards or industry expectations, it is imperative that you discuss the deviation with the crew foreman. Please ask "why" and document what we can do to improve. The deviation should only be documented enough for someone to understand what we need to fix
- At the end of the observation, promptly provide feedback to worker being observed (both positive & corrective)
- Look for opportunities to provide positive feedback to the employee, and where appropriate, inform their supervisor

### Attributes of a Good Observation:

- Provide onsite feedback to worker being observed or to the crew foreman (both positive and corrective)
- Meaningful data and comments/insights/impressions recorded for later trending and analysis
- Strong points should be shared with other groups
- Weaknesses should be immediately addressed; i.e., follow-up with supervision, crew foreman or other appropriate person

**NOTE:** Use contractor names when entering information in the comments, including the name of the crew foreman and/or inspector on-site. The intent of the program is to improve and foster safe working conditions with contract work.

### Quality Observations:

Observations should provide two important pieces of information:

- 1) Instant feedback – both positive and corrective, to the contractor being observed
- 2) Meaningful data/comments recorded to permit a later analysis of the observation; Mere "Sat" remarks with no narrative comments are of limited value.

## **APPENDIX H**

### **Example H&S Metrics Form**

## Health and Safety Metrics Report

Date:	
Company:	
Reported By:	
Project Name:	
Project Address:	

Summary Data	[Week]	[Month]	[Year]
	Weekly Total	Monthly Total	Year to Date
Total Safe Man Hours:			
-Contractor personnel:			
-Subcontractor personnel:			
Near miss/ hit:			
First aid cases:			
Lost work days cases:			
Lost work days:			
Restricted work day cases:			
Recordable cases:			
<b>Safety Indicators</b>			
Average number of employees:			
Number of JSAs completed and approved:			
Number of tool box talks reviewed with crew:			
Number of safety meeting:			
Number of safety observations:			
Number of site inspections:			
Number of employees trained:			
Number of training hours:			
Number of disciplinary actions:			
Number of job(s) stopped for safety risk/violation:			
Number of occupational exposure assessments:			

## **APPENDIX I**

### **PG&E Code of Safe Practices – Relevant Sections**



CODE OF SAFE PRACTICES

Safety and Health Program  
(Accident Prevention Rules)

**2018 Edition**  
**Supersedes all previous editions and revisions**

**Published by the**  
**Safety and Health Department**  
**Pacific Gas and Electric Company**

## **Pacific Gas and Electric Company Employees:**

At PG&E, nothing is more important than public, employee, and contractor safety. We've set our sights on making our company the safest utility in the country. It is incumbent upon each of us to do our work in a manner that promotes the safety and well-being of ourselves, our coworkers, our contractors, our customers, the Company, and the public. The Company's aim to create an injury, illness, and loss-free work environment will only be achieved with the dedication and commitment of each and every employee.

The Company's Safety and Health Program Standard (SAFE-1001S), as well as our thorough standards, procedures, work processes, job expectations, and human performance tools, lays out the specific roles and responsibilities for working safely.

The "Code of Safe Practices" has been developed by the Company in collaboration with the IBEW, ESC, and organizational grassroots safety teams. It is your responsibility to read, review, and follow it. Remember to consider safety, health, and wellness in every task, look for and act to resolve unsafe situations, and help and encourage others to act safely.

It will take all of us working together to create a culture where safety, health, and wellness are at the forefront of everything we do at PG&E.



The Code of Safe Practices (CSP) is a field reference and **NOT** a complete list of all Company standards and procedures related to safety. The content in the CSP does not replace or supersede Pacific Gas and Electric Company standards and procedures. If there is a discrepancy, the standard or procedure takes precedence over the information contained in the CSP.

# TABLE OF CONTENTS

---

## **SAFE-1001S - Safety and Health Program Standard**

### **Safety Principles**

#### **Basic Safety Requirements**

##### **Section 1**

General Rules

##### **Section 2**

First Aid

##### **Section 3**

Motor Vehicle Operation

##### **Section 4**

Electric Transmission and Distribution  
Overhead

Section 04 - Appendix

##### **Section 5**

Pole Handling Operations

Section 05 - Appendix

##### **Section 6**

Live Line Work Methods: Rubber Gloving  
Overhead Distribution Bare Hand Work Use,  
Maintenance, and Care of Live Line Tools

Section 06 - Appendix

# TABLE OF CONTENTS

---

## **Section 7**

Electric Transmission and Distribution  
Underground  
Section 07 – Appendix

## **Section 8**

Electric Substations

## **Section 9**

Hydro Power Plants

## **Section 10**

Fossil Power Plants

## **Section 11**

Helicopter Safety

## **Section 12**

Telecommunications

## **Section 13**

Gas Distribution and Transmission Systems

## **Section 14**

Gas Transmission Stations

## **Section 15**

Gas  
Service

**Data**

**Section**

**Index**

# TABLE OF CONTENTS

---

## TABLE OF CONTENTS

---



## TABLE OF CONTENTS

---

# Better communication, stronger safety: Words we can live with.

This is about the power of words to make things better. How the right discussion at the right moment can motivate people to think ahead. The way that honest and supportive communication, no matter how tough, opens eyes and minds to unseen risks. And the singular truth that speaking up about mistakes is the best way for all of us to learn from them. It's all part of changing the safety conversation at PG&E. And that, of course, starts with you.

*For insights, resources and ideas, visit the PG&E@Work site: <http://SpeakUpForSafety>.*

*Actions may speak louder than words, but in safety, words are often what lead to the right actions. —PG&E Leader*



## TABLE OF CONTENTS

# Conversation starters: Defining the difference.

When you come right down to it, safety isn't just a value we share. It's also a series of small choices that have to be made in the moments that matter. And that's why it's so important to change how we think about, talk about, and act about safety. Before, during and after every job. Each and every day. Which is why we're changing the conversation.

FROM:	TO:
Looking behind, counting incidents.	Looking ahead to minimize risks.
Talking about what happened.	Talking about how and why it happened.
Instructing people about what to do.	Discussing why we need to do it.
Fault finding to assign blame.	Fact-finding to eliminate repetition.
Comply because I'm supposed to.	Commitment <i>because I want to</i> .
Great team leaders on the job.	Great safety leaders on every job.
Pointing fingers at unsafe behavior.	Applauding the right safety actions.

*Instructing me to wear a hard hat, safety glasses, or gloves tells me what's expected. Talking about protecting my head, eyes, and hands tells me why.*  
—PG&E Employee

## TABLE OF CONTENTS

---

# Speaking up works: Here's proof.

We've already seen that changing the conversation helps us get the right results. Just look at how our Corrective Action Program (CAP) in Power Generation, Gas Operations and Safety & Shared Services has turned input from hundreds of our coworkers into problems seen and solved.

Or how thousands of employees got the injury care they needed by calling the 24/7 Nurse Report Line right away.

Or the way proactive ergonomic training in Electric Distribution Operations resulted in a 100 percent reduction in workdays lost to major physiological injuries.

And that brings us to one major area where you can help. Let us know whenever you see examples that demonstrate how speaking up about safety results in a safer PG&E. It's not only good learning, but more proof that we can, and will, achieve our highest safety goals.

*Share your examples through PG&E@Work:*  
**<http://SpeakUpforSafety>.**

*I don't ask if it's possible for a company of 23,000 people in a complex industry to achieve a flawless safety record. I ask what's holding us back? —*  
**PG&E Leadership Coach**

## TABLE OF CONTENTS

---

# Turning words into action: Speaking out and stepping up.

Ask just about anyone who works at PG&E and they'll tell you that safety has to be the most important part of everything we do. That's why it's critical that we build effective safe behaviors into our daily work practices.

Here's what you should expect to see on the job:

- Teams making sure morning briefings, tailboards, and meetings all include “stop and speak up” discussions of observed or potential risks, as well as proven procedures to mitigate them.
- Leaders ensuring safety is always on the agenda. That includes encouraging frank conversation about exposures, what worked and went well, and how we can improve next time. Never miss an opportunity to recognize and celebrate safe behaviors.
- Everyone being told that stopping or pausing work is a universal right and responsibility—whether the risk relates to physical conditions, confusion, or a lack of understanding about the job at hand. Your best course of action: ask those involved to stop or pause, identify the hazard, and then calmly discuss appropriate next steps.

*Find easy-to-access tools, tips and resources at  
PG&E@Work: <http://SpeakUpforSafety>.*

## TABLE OF CONTENTS

---

# Ending, and beginning with some frank conversation.

Now that you know the what, why, and how of our program, there's one more thing to discuss. And that's to admit that changing the conversation on safety isn't exactly the world's easiest job, even if it is the most important thing we can do for ourselves and each other. Here's how you can start the conversation:

- Raise your hand and your voice when you see a safety issue of any sort. It doesn't matter whether the item is big, small or in between. If you see it, say it.
- Don't be afraid to "bother" your teammates with this stuff. Nobody will be "bothered" if it means everyone goes home safe and healthy.
- Make sure to give team members support when they have the guts to speak up. We all know how tough it is to point out unrecognized hazards and lessons learned. A little encouragement will go a long way.
- It's fair to expect your supervisors and senior employees to take the lead on safety conversations. It's also essential to prompt them, if they don't. Nervous about that? Ask a work buddy to join the talk.
- If you have any questions at all about the risk-free nature of speaking up, call Compliance and Ethics at 1-888-231-2310.

*See inspiring examples of employees leading with safety at PG&E@Work: <http://SpeakUpforSafety>.*

# TABLE OF CONTENTS

---

## Keys To Life

**To assure your safety and that of your coworkers and the public:**

- Follow safe driving principles
- Use appropriate life-saving personal protective equipment (PPE)
- Follow electrical safety testing and grounding rules
- Follow clearance and energy lock-out rules
- Follow confined space rules
- Follow suspended load rules
- Follow safety at heights rules
- Follow excavation procedures
- Follow hazardous environment procedures

## TABLE OF CONTENTS

---

### **Summary:**

This standard describes Pacific Gas and Electric Company's (PG&E's) Safety and Health Program, which each organization is to integrate into all business systems and work processes. This standard and its implementing procedures are PG&E's written Injury and Illness Prevention Program (IIPP), which is required under California law and or Federal law.

### **Target Audience:**

Officers, directors, and their designees, all of whom are responsible for integrating the Safety and Health Program into their business systems and work processes.

### **Safety:**

Performing the procedures that implement this standard will diminish the risk of specific hazards to personnel, the public, and equipment.



# TABLE OF CONTENTS

## Contents

---

### Subsection

- 1 Safety and Health Program Integration
- 2 Training
- 3 Human Performance Tools
- 4 Adequate Communication
- 5 Basic Safety Rules
- 6 Employee Involvement
- 7 Performance Management
- 8 Measurement and Evaluation
- 9 Records Management

# Requirements **TABLE OF CONTENTS**

---

## 1 **Safety and Health Program Integration**

1.1 Each officer, director, and designee is responsible for developing and implementing plans to integrate the four steps of the Safety and Health Program into all business systems and work processes:

1. Identify hazards
2. Evaluate hazards
3. Control hazards
4. Evaluate controls

1.2 The following methods are to be used to develop and implement these plans to ensure employees are familiar with and comply with the Safety and Health Program:

1. Training
2. Human Performance Tools
3. Adequate Communication
4. Basic Safety Rules
5. Employee Involvement
6. Performance Management
7. Measurement and Evaluation
8. Records Management

## **TABLE OF CONTENTS**

### **2 Training**

---

- 2.1 Training includes the following:
1. Incorporate the four steps of the Safety and Health Program
    - a. Take proactive steps to identify hazards
    - b. Evaluate the hazards
    - c. Control the hazards
    - d. Evaluate the hazard controls
  2. Teach employees, about the hazards relevant to the business systems and work processes they deal with and how to implement the necessary hazard controls.
  3. Train employees when the hazards they will face change.
  4. Familiarize each employee with group participation techniques.
  5. Ensure contractors and temporary agency workers receive similar training from their employers before starting work for PG&E.

### **3 Human Performance Tools**

- 3.1 Human performance tools include the following:
1. Tailboards
    - a. Ensure organization leaders provide tailboards before performing work and when work conditions change.
    - b. Include the task purpose, scope, sequence and nature of work.
    - c. Review applicable procedures, drawings, documents, prerequisites, or any other items needed to perform the work.
    - d. Use three-way communication to

## TABLE OF CONTENTS

---

validate that task assignments are understood and roles and responsibilities for the work are clear. This includes limits of the required work; work hand-offs, controlling authority or person-in-charge as, and emergency procedures and contacts.

2. Two-Minute Rule
  - Coach employees to STOP and take two-minutes (two-minute rule) to think through the work/task and understand the hazards and the controls to improve situational awareness before beginning a task and to check for changing conditions.
  
3. Self-Checking STAR (Stop, Think, Act and Review)
  - a. Stop
    - 1) Take the time to pause and focus on the task to be performed
    - 2) Eliminate distractions
  - b. Think
    - 1) Think about the task to be performed
    - 2) Understand what is to be done
    - 3) Know the expected responses and indications of that action
    - 4) Determine if the task is appropriate for the given conditions
    - 5) Identify the correct component
    - 6) Plan the actions to take if the response is not as expected
  - c. Act

## TABLE OF CONTENTS

- 
- 1) Perform the task
- 
- d. Review
    - 1) Evaluate the results of the action
    - 2) Verify the correct, expected response
    - 3) Take planned actions if the response is not as expected
  4. Stop When Unsure
    - When a question on the job or while performing work arises, creating uncertainty, stop and ask questions to understand what the work is, the hazards involved and how to perform the work.
  5. Questioning Attitude
    - Foster situational awareness, encouraging thought about safety before action is taken.
  6. Procedure Use and Adherence
    - Work is to be performed in accordance with approved procedures and supporting documents. Understanding the overall purpose and strategy of the procedure promotes safer outcomes.
  7. Placekeeping
    - Documents completion of procedural steps.
  8. Phonetic Alphabet
    - Use when communicating information related to equipment or components.
  9. Three-Way Communication
    - Promote a reliable transfer of information and understanding ensuring the correct action is taken.

# TABLE OF CONTENTS

---

## 4 **Adequate Communication**

4.1 Includes, but is not limited to the following:

- Workgroup meetings
- Jobsite tailboards
- Inter-departmental agreements
- Contract language
- Bulletin board postings
- Electronic media

4.2 Collect input from stakeholders and ensure they are informed of the outcome when participating in an industry or regulatory forum, such as the American Society for Testing and Materials (ASTM) or OSHA-Advisory committee.

## 5 **Basic Safety Rules**

- Inform employees that compliance with the Code of Safe Practices is a condition of employment.
  - a. Communicate updates or revisions to all standards, procedures, and rules relevant to the employees' work.

## 6 **Employee Involvement**

- Involve employees in the Safety and Health Program on an on-going basis. When specific safety and health issues are to be resolved, use Grass Roots Teams, chartered safety/ad hoc teams, or workgroups comprised of critical



# TABLE OF CONTENTS

stakeholders.

---

## 7 **Performance Management**

- Integrate the Safety and Health Program into all work through individual job expectations and team charters.
- To define team expectations, use a charter that defines purpose, scope of authority, roles and responsibilities, communication and documentation requirements, and required resources.
- Hold individuals and teams accountable through recognition and disciplinary action. Use PG&E's Human Resources programs of Performance Management for management and applicable A&T employees and Positive Discipline for bargaining unit employees.

## 8 **Measurement and Evaluation**

- Establish goals to measure Safety and Health Program progress.
- Evaluate integration of the Safety and Health Program into all work through work site observations, inspections or other observations.

## 9 **Records Management**

- Document and maintain training records until subsequent training is provided to employees.
- Document and maintain all other Safety and Health Program Records for at least three years. Records identified in the Guide to Record Retention must be maintained for the

## **TABLE OF CONTENTS**

period of time specified Per GOV-7101S

---

Enterprise Records and  
Information Management Standard

**END of Requirements**

<b>Rule</b>	
<b>P-1</b>	<b>Scope</b>
<b>P-2</b>	<b>Training and Education</b>
<b>P-3</b>	<b>Knowledge</b>
<b>P-4</b>	<b>Compliance</b>
<b>P-5</b>	<b>Emergencies</b>
<b>P-6</b>	<b>Interpretation</b>
<b>P-7</b>	<b>Supplementary Information</b>
<b>P-8</b>	<b>Governmental Safety Standards</b>
<b>P-9</b>	<b>Care in Performance of Duties</b>
<b>P-10</b>	<b>Qualifications for Duty</b>
<b>P-11</b>	<b>Employee Responsibilities</b>
<b>P-12</b>	<b>Reserved</b>
<b>P-13</b>	<b>Intoxicants and Controlled Substances</b>
<b>P-14</b>	<b>What to Do If an Incident Occurs</b>
<b>P-15</b>	<b>Housekeeping</b>
<b>P-16</b>	<b>Reserved</b>
<b>P-17</b>	<b>Control and Elimination of Hazards</b>

**P-1. Scope**

- (a) This Code of Safe Practices applies to Company employees. Acceptance of employment constitutes acceptance of these rules.
- (b) When an employee of one department is assigned to work on equipment or facilities subject to the jurisdiction of another department, the employee shall follow these rules and any supplemental rules of the latter department.

**P-2. Training and Education**

- (a) Employees shall follow the instructions and advice concerning the rules and their application, as provided by their supervisor or foreman.
- (b) Employees shall attend mandated and specialized training, as assigned, and demonstrate comprehension, if requested.
- (c) Employees shall discuss areas of uncertainty with the instructor.
- (d) Employees shall notify their supervisor should they require additional training or instruction or if they have been requested to perform work for which they have not been trained.

**P-3. Knowledge**

Before conducting work, employees shall know and understand the rules that apply to the work to be performed.

**P-4. Compliance**

- (a) Employees shall comply with this Code of Safe Practices and applicable safety policies, instructions, practices, procedures, rules and/or requirements.
- (b) If a difference arises in the application or interpretation of these rules, employees shall follow the decision of the employee-in-charge in

conformance with established work rules and practices.

**P-5. Emergencies**

- (a) In case of an emergency that may result in a serious personal injury or property damage, these rules may temporarily be modified or suspended as necessary by the appropriate people to permit proper handling of the emergency. In any such case, the person so acting, shall be fully accountable for the reasonableness of such actions and for any incident or service interruption that results from such actions.
- (b) Employees shall follow their organization's emergency response procedures.

**P-6. Interpretation**

These rules shall be strictly interpreted to bring about maximum compliance and safe conduct., However, lawful and applicable governmental regulation that may be contrary to these rules shall override these rules, as applicable.

**P-7. Supplementary Information**

Employees shall be familiar with and use additional instructions and information relating to safe performance of work that supplement this Code of Safe Practices, as provided by supervisors, such as letters, operating instructions, departmental standards, procedures, guidelines, bulletins, etc.

**P-8. Governmental Safety Standards**

Employees shall comply with applicable provisions of governmental laws and regulations. In addition to this Code of Safe Practices and supplementary information, the Company and its

employees, in the performance of their work, are also subject to the regulations of federal, state, county, and municipal agencies, such as the California Department of Industrial Relations' Division of Occupational Safety and Health, local departments of environmental health, and fire prevention bureaus or agencies.

**P-9. Care in Performance of Duties**

- (a) Employees shall not engage in practical jokes, scuffling, "horseplay", or the urging of persons to take unnecessary chances, shortcuts or un-safe behaviors.
- (b) Employees shall use reasonable care at all times in the performance of their duties and act in such a manner as to maximize their own safety, as well as the safety of their fellow employees and the public.

**P-10. Qualifications for Duty**

- (a) Employees shall only perform work for which they are qualified and authorized to perform, have been trained to perform, and are mentally and physically capable of performing.
- (b) Only Qualified Persons shall be assigned to work on equipment or facilities.

Qualified Person: A Qualified Person is, by regulatory definition, a person designated by the employer who has received training in and demonstrated skills and knowledge in the construction and operation of electric equipment and installations and the hazards involved, by reason of experience and training, has demonstrated the ability to safely perform assigned duties and, when required, is properly licensed in accordance with federal, state, or

local laws and regulations. An employee who is undergoing on the job training and who, in the course of such training, has demonstrated an ability to perform duties safely at his or her level of training and who is under the direct supervision of a Qualified Person is considered to be a Qualified Person for the performance of those duties. In addition to the requirements set forth above, a Qualified Person must:

- (1) Complete training that enables the employee to safely and competently perform the tasks that are specific to the employee's job classification (e.g. Street Light worker, Equipment Operator, MEO, T&D assistant, etc.)
- (2) Demonstrate the ability to safely and competently perform the tasks that are specific to the employee's job classification; and
- (3) Be able to identify and mitigate the hazards that are specific to the tasks performed in the employee's job classification.

*Note: All documentation of training mentioned above must be retained and made readily available upon request.*

- (c) Only Competent Persons shall perform work that is required by regulation to be performed by a Competent Person.

**Competent Person:** A Competent Person is, by regulatory definition, a person who is capable of identifying existing and predictable hazards in the surroundings, or working conditions that are unsanitary, hazardous, or dangerous to



employees, and who has authorization to take prompt corrective measures to eliminate them.

- (d) Only Qualified Electrical Workers shall perform work that is required by regulation to be performed by a Qualified Electrical Worker.

Qualified Electrical Worker: A Qualified Electrical Worker is, by regulatory definition, a qualified person who has a minimum of two years of training and experience with high-voltage circuits and equipment and has demonstrated by performance, familiarity with the work to be performed and the hazards involved. The following additional requirements only apply to Electric Transmission and Distribution employees designated as a QEW:

- 1) Journeymen Linemen classification or higher when working on or around energized facilities in excess of 600 volts
- 2) Has received training and has demonstrated the ability to competently to perform the following:
  - a. Distinguish exposed live parts from other parts of electric equipment
  - b. Determine the nominal voltage of exposed live parts
  - c. Know the minimum approach distances for the voltages exposed
  - d. Know the precautionary techniques, personal protective equipment, insulating and shielding materials, and insulated tools to be used at all times when working on or near exposed energized parts of electric equipment

- e. Understand and be able to recognize all other hazards and potential hazards of working on and around high voltage equipment in excess of 600v whether or not energized parts are exposed.

*Note: All documentation of training mentioned above must be retained and made available upon request.*

- (e) Employees in training, who are qualified by experience and training, shall be permitted to work on energized conductors or equipment connected to high-voltage systems while under the supervision or instruction of a qualified electrical worker. Employees in training shall not work alone.
- (f) Qualified/Competent Persons shall receive and attend ongoing safety training to maintain Qualified/Competent Person status. This may be a combination of on-the-job training, tailboard safety topic reviews, briefings, classes and competency evaluations.
- (g) An employee shall no longer hold Qualified/Competent Person status should they fail to comply with the requirements of this Code of Safe Practices or demonstrate incompetence or inability to perform their work safely.

**P-11. Employee Responsibilities**

- (a) Employees shall know the rules that apply to the work being performed before conducting the work. Employees who do not understand or who have questions about the rules shall contact their supervisor.

- (b) Each employee shall be thoroughly familiar with the equipment they have been assigned to operate and with applicable approved operating procedures and practices, which shall be strictly followed.
- (c) Where employees have identified unsafe operations, the employee shall report the hazards to their supervisor. In situations where they have been trained to do so, they shall control the hazard.
- (d) Employees shall not work while their ability or alertness is so impaired by fatigue, illness, or other causes that it might unnecessarily expose the employee or others to injury.
- (e) Employees are responsible to look for and act to resolve unsafe situations or conditions.

**P-12. Reserved****P-13. Intoxicants and Controlled Substances**

- (a) Use of intoxicants or non-medically prescribed controlled substances (drugs), or derivatives thereof, by an employee while engaged in Company business is prohibited.
- (b) Use of prescription/non-prescription drugs is permitted if the medication does not jeopardize the employee's safety and health and/or the safety of others.

**P-14. What to Do If an Incident Occurs**

- (a) Employees shall understand and comply with the Emergency/First Aid Plan where they work.
- (b) Employees shall report to their supervisor all incidents involving near hits, illnesses, or injuries in accordance with SH&C Procedure 202 and their organization's incident reporting procedures.

---

Employees shall participate in subsequent investigations.

(c) Employee Injury

- (1) The first employee having knowledge of the injury shall report injuries needing emergency medical attention by following local procedures to notify one or more of the following, by the fastest means of communication:
  - a. 9-1-1
  - b. Other contact, as identified in the Emergency/First Aid Plan
  - c. The nearest headquarters of the person making the report
  - d. The nearest Company office or plant
  - e. The Distribution Center Operator, Electric Control Center Operator, Service Operator, or Telecommunications Control Center Operator.
- (2) The notifying employee shall provide sufficient and accurate information to the emergency medical services or others responding to the call including the nature of the emergency and the exact location of and directions to the scene of the incident.
- (3) Every injured employee shall receive First Aid/CPR as soon as possible. Employees are required to either immediately secure medical assistance for or provide First Aid/CPR to injured employees. Only employees who are certified in First Aid/CPR

- may provide First Aid/CPR. See Section 2, *First Aid*.
- (4) When possible, at least one employee should stay with the injured employee, providing necessary First Aid/CPR if they are trained to do so until emergency personnel arrive.
  - (5) Employees shall immediately report any employee injury or illness to their supervisor and then call the 24/7 Nurse Report Line at 1-888-449-7787.
  - (6) In the event of a serious employee injury (as defined in SAFE-1004S), the employee-in-charge shall immediately call the Serious Incident Notification Line at 8-223-8700 or 415-973-8700, option 1.
  - (7) Injured or ill employees who require a doctor's care should see a Company panel physician unless the individual has previously designated in writing their personal physician. The injured employee should be accompanied to the doctor or hospital by another employee or the supervisor.
  - (8) Supervisors or supervisor designee are responsible to secure incident sites, interview, collect and secure evidence, and take photographs.
- (d) Non-Employee Injury
- (1) Employees shall comply with the requirements of the Litigation and Claims Procedure with regards to incidents that involve or may involve third party injury, fatality, or property damage.

- 
- (2) Employees shall notify the following, by the quickest means of communication, of incidents that may involve the Company and result in injury to or death of non-employee:
    - a. 9-1-1, if necessary, and
    - b. The nearest headquarters of the person making the report and/or,
    - c. The nearest Company office or plant and/or,
    - d. The Distribution Center Operator, Electric Control Center Operator, Service Operator, or Telecommunications Control Center Operator.
  - (3) Employees shall immediately notify the Law Claims Investigator at 415-973-8000 for an incident involving:
    - a. Third party personal injury
    - b. Third party or Company property damage of any amount.
  - (4) Employees providing first aid do so at their own discretion and shall not assume responsibility for any injury. See Section 2, *First Aid*.
  - (5) Employees shall not obligate the Company to pay for ambulance, doctor, hospital services, or for repairs to or replacement of damaged property.
  - (6) Employees shall not make statements admitting liability or indicating that the Company will make settlement.
  - (7) Employees shall not discuss the incident in the presence of non-employees with the exception of law enforcement officials and only at their request.

- 
- (8) Witnessing employee(s) shall obtain the names, addresses, and telephone numbers of the injured person(s) and witnesses.
  - (e) Automobile, Forklift and Off-Road Utility Vehicle (OUV) Incidents
    - (1) In the case of incidents involving the operation of a Company vehicle, or an employee-owned vehicle being driven on Company business, employees shall follow SAFE-1002S – Motor Vehicle Standard.
    - (2) Employees shall immediately notify the Law Claims Investigator by calling 415-973-8000 for any incident involving:
      - a. Employee or third party personal injury
      - b. Third party property damage of any amount.
      - c. Company property damage of any amount.

For other incidents, an incident report must be entered into the RiskMaster incident database within 24 hours of the incident.

- (f) Property Damage to Third Parties
  - (1) Employees shall immediately report incidents resulting in damage to the property of others to a supervisor and, where required by the Litigation and Claims Procedure, to Law Claims.
  - (2) Employees shall not make statements admitting liability or indicating that the Company will assume responsibility for the incident.
  - (3) Employees shall report the facts known about the incident to their supervisor or employee responding to the incident.



**P-15. Housekeeping**

- (a) Employees shall maintain work locations, facilities, and vehicles in a neat and orderly manner to maintain a safe and healthful work environment.
- (b) Combustible materials shall be placed in suitable containers in areas provided for that purpose and shall not be allowed to accumulate on benches, floors, yards, hallways, stairways, or vehicles. Combustible materials include but are not limited to: oil-soaked and paint-covered rags, waste, shavings, packing, and rubbish.
- (c) Floors, stairways, and platforms shall be free of dangerous projections, obstructions or penetrations and shall be maintained in good repair, and reasonably free from oil, grease, or water.
- (d) Where the work necessitates working on slippery floor areas, such surfaces shall be protected against slipping by the use of mats, grates, cleats, or other methods.
- (e) Floors, stairways, and platforms shall be constructed and maintained to safely support the loads to which they are subjected.
- (f) Stairways, aisles, exits, roadways, and walkways in material storage areas shall be kept clear and free from obstructions, depressions, and debris.
- (g) Materials, supplies and tools shall be stored in an orderly manner and secured to prevent falling or spreading, and to eliminate tripping / falling hazards.
- (h) Compressed air shall not be used for cleaning purposes, unless an approved pneumatic blow gun is used, limiting pressure to 10 psig.

- (i) Compressed air shall not be used when asbestos materials are present, to clean clothing or hair, or be turned against any person for any reason.

**P-16. Reserved**

**P-17. Control and Elimination of Hazards**

- (a) When employees may be exposed to hazards such as noise, electricity, natural gas, and/or airborne contaminants that make the workplace unsafe, feasible engineering and/or administrative controls shall be implemented to eliminate or minimize the hazard(s) or exposure by controlling it at its source.
- (b) When the hazard(s) cannot be eliminated, or controlled to a safe level through engineering controls (e.g., changing the process or equipment, using ventilation, isolating the hazard, substituting a safer chemical) or administrative controls (e.g., work schedule changes to minimize the exposure), employees shall follow Company work procedures and use appropriate personal protective equipment (PPE). See the Safety Equipment Guide for more information.

---

**GENERAL RULES**  
**Contents**

<b>Rule</b>	
<b>1</b>	<b>Tailboard Briefings</b>
<b>2</b>	<b>Personal Protective Equipment</b>
<b>3</b>	<b>Head Protection</b>
<b>4</b>	<b>Face and Eye Protection</b>
<b>5</b>	<b>Hand and Foot Protection (Revised 5/2018)</b>
<b>6</b>	<b>Noise Control</b>
<b>7</b>	<b>Respiratory Protection</b>
<b>8</b>	<b>Fall Protection</b>
<b>9</b>	<b>Scaffolds and Falsework</b>
<b>10</b>	<b>Ladders</b>
<b>11</b>	<b>Clothing and Jewelry</b>
<b>12</b>	<b>Hazard Communication</b>
<b>13</b>	<b>Flammable Liquids</b>
<b>14</b>	<b>Fire Protection</b>
<b>15</b>	<b>Compressed Gases</b>
<b>16</b>	<b>Lights</b>
<b>17</b>	<b>Welding, Cutting, Metalizing, Soldering, and Use of Open Flames</b>
<b>18</b>	<b>Heat Illness Prevention (Added 1/2018)</b>
<b>19</b>	<b>Smoking</b>
<b>20</b>	<b>Confined Spaces</b>
<b>21</b>	<b>Water Safety</b>
<b>22</b>	<b>Electrical Hazards</b>
<b>23</b>	<b>Clearances</b>
<b>24</b>	<b>Responsibilities for Primary Operations</b>
<b>25</b>	<b>“Man on Line” and “Caution” Tags</b>
<b>26</b>	<b>Cleaning, Repairing, Servicing, Adjusting, and Un-jamming Machinery and Equipment</b>
<b>27</b>	<b>Reserved</b>
<b>28</b>	<b>Machine Guards</b>
<b>29</b>	<b>Tools and Equipment</b>

**GENERAL RULES**

**Contents**

- 30 General Office Work
- 31 Ergonomics
- 32 Packing, Unpacking, Storage, Loading, and Unloading of Materials **(Revised 1/2018)**
- 33 Reserved
- 34 Work Area Protection
- 35 Transportation
- 36 Cranes, Hoists, and Derricks **(Revised 4/2018)**
- 37 Meter Reading and Collection
- 38 Radio Operation
- 39 Rigging

**1. Tailboard Briefings**

- (a) Employees shall participate in tailboard briefings given by the employee-in-charge of the job. Conduct a tailboard before performing a job to discuss tasks involved, hazards and related safety precautions. Conduct a tailboard: once per shift, prior to performing work, after extended delays in activity, anytime the jobsite activities change. After the briefing, each crew member should be able to demonstrate knowledge of:
- (1) The work methods, procedures, and proper sequences for the job. This includes the task purpose, scope sequence, nature of work, review of procedures, work package documents, drawings, turn-over information, prerequisites, etc. that will be used to complete the task.
  - (2) What he/she and the other members of the crew are to do including task assignments, identifying and understanding roles and responsibilities, qualifications, personal limitations, hand-offs, and the controlling authority.
  - (3) The responsibilities and appropriate actions in emergency situations including emergency procedures and emergency contacts.
  - (4) The potential or known hazards or trouble spots involved and the controls to mitigate the hazards including identification of safety hazards, work procedures involved, special precautions, control of energy sources including permits and clearances, personal protective equipment (PPE) and utilization of

Human Performance tools for each critical step relevant to risk with industrial, environmental, safety and operations.

- (5) What other work is going on in the area (e.g., PG&E, contractor, County, etc.).
- (b) If the job task or conditions change such that employees become aware of a hazard about which they have not received a tailboard briefing, they shall stop work and notify their supervisor or the employee-in-charge.
- (c) A tailboard briefing is a pre-work meeting or discussion held in a safe location, (usually at the job site), to discuss job activities before starting the work and again at any time conditions at the job site change (e.g., work scope or activities change, crew members change, new equipment introduced, contractor activities change, etc.). Tailboard briefings encourage employee involvement and participation.

## 2. **Personal Protective Equipment**

- (a) Employees shall be provided with personal protective equipment (PPE) suitable for the hazard (such as hearing protection for noise exposure, respirators for airborne respiratory hazards, gloves for thermal, chemical, electrical or impact hazards, etc.) and, prior to use of the PPE, shall receive training on:
  - (1) When PPE is necessary
  - (2) What PPE is necessary
  - (3) How to properly don, doff, adjust, and wear PPE
  - (4) Limitations of the PPE
  - (5) The proper care, maintenance, useful life, and disposal of the PPE.

- (b) Employees shall use only Company approved personal protective equipment that meets regulatory standards and is properly fitted to ensure that the equipment provides adequate protection from the anticipated exposures.
- (c) Employees shall inspect PPE before each use to assure proper fit and that the item has no damage, deterioration or other condition that might impact its effectiveness and protective qualities. PPE that is found to be damaged, deteriorated or defective shall not be used but tagged, removed from service (and notice given to the supervisor of its condition), or destroyed as authorized by the supervisor.
- (d) If employees suspect that they may need PPE or are unsure if they need PPE, they shall notify their supervisor or contact their safety representative for guidance.
- (e) When employees may be exposed to hazards such as noise, electricity, natural gas, and/or airborne contaminants that make the workplace unsafe, feasible engineering and/or administrative controls shall be implemented to eliminate or minimize the hazard(s) or exposure by controlling it at its source. When the hazard(s) cannot be adequately controlled to a safe level through engineering controls (e.g., changing the process or equipment, using ventilation, isolating the hazard, substituting a safer chemical) or administrative controls (e.g., work schedule changes to minimize the exposure), employees shall use appropriate personal protective equipment.



**3. Head Protection**

- (a) Employees shall wear a hard hat, furnished by the Company, when exposed to energized conductors or apparatus, falling or flying objects, or as required by the employee-in-charge. Hard hat and suspension will be inspected prior to use.
- (b) Hard hats shall not be painted, drilled, or marked by stamping, scratching, cutting or by any method which defaces the shell.
- (c) For the purpose of identification, employees may place their name and classification on the shell, using vinyl tape labels.
- (d) Only three decals, in addition to the Company logo, may be applied to the exterior of hard hats.
  - (1) Decals shall be related to the Company and its unions, and be Company-approved.
  - (2) Decals shall be placed on the sides or back of the shell, not on the brim nor extend more than 3 inches from the junctures of the brim and crown, and shall not interfere with the Company logo or another decal.
  - (3) Decals shall be non-metallic. Each decal shall cover an area no larger than 4 square inches (e.g., 2 inches by 2 inches).
- (e) When replacing accessories, manufacturer's standard parts shall be used.
- (f) Employees are responsible for reporting identified cracking or chipping to their supervisor who shall determine if replacement is necessary.
- (g) Replacement shall occur annually for suspension parts and at least every 5 years from the date of issue for the shell, or as required by the manufacturer's instructions.

- (1) Employees shall write the date of issue on the inside of the hard hat with a permanent marker.
  - (h) Employees shall store hard hats/caps away from sunlight and extreme heat or cold, and not on the shelf in the rear of passenger vehicles.
  - (i) Ball caps, beanies, skull caps, hooded sweatshirts, etc., shall not be worn under hard hats, as this impedes the protection factor of the hard hat. Hoods (either hooded sweatshirts or rain wear hoods) may be worn over the hard hat.
- NOTE:** Working in the Arc Flash Boundary requires proper FR clothing be worn.

#### **4. Face and Eye Protection**

##### **(a) Combined Face and Eye Protection**

- (1) Employees shall wear Company-approved face shields and eye protection in work situations where there is the possibility of receiving eye injuries such as punctures, abrasions, contusions, or burns as a result of contact with flying particles, hazardous substances, projections or injurious light rays which are inherent in the work or environment, shall be safeguarded by means of face or eye protection
- (2) Wearing a face shield alone is not approved eye protection.

##### **(b) Eye Protection**

- (1) Employees who work on jobs that require eye protection shall wear eye protective devices that comply with the applicable American National Standards Institute (ANSI) standards. Employees shall wear

eye and face protection when engaged in, or in the vicinity of work involving:

- a. Drilling or chipping stone, brick, concrete, paint, pipe coatings, or metal
- b. Grinding, buffing, or wire brushing,
- c. Dust or flying particles
- d. Welding, cutting, or burning
- e. The use of hot or hazardous substances
- f. Injurious light or heat rays
- g. The use of a chain saw.
- h. Any other job where there is potential danger of eye injury.
- i. As recommended by Safety Data Sheets (SDS)

(2) Side shields shall be used with eye protective devices whenever the hazard of flying objects is angular as well as frontal.

(c) **FR Eye/Face Protection** – employees working on energized conductors or apparatus or performing switching operations, shall wear approved eye/face protection as follows:

(1) When required by departmental procedures, appropriate FR eye/face protection must be worn. FR eye/face protection consists of the following three levels:

- a. Level 1: Level 1 eye/face protection consists of arc-rated face shield with a minimum rating of 8 cal/cm<sup>2</sup> and safety glasses or goggles.
- b. Level 2: Level 2 eye/face protection consists of one of the following options:
  - 1) FR balaclava (double layer sock hood) with a minimum rating of

- 25 cal/cm<sup>2</sup>, safety glasses, and an arc-rated face shield.
- 2) FR balaclava (double layer sock hood) with a minimum rating of 25 cal/cm<sup>2</sup> and an arc-rated goggle.
- 3) FR hood rated 25 cal/cm<sup>2</sup> or greater.
- c. Level 3: Protective switching suit hoods that come as part of Oberon protective switching suits.

**NOTE:** During daylight hours, where visibility is not hampered: Company approved safety glasses or plastic coverall goggles and Flame Resistant (FR) rated face shield with shaded lenses can be worn. During darkness, or other times when visibility is hampered: Company approved clear, amber, or plastic safety glasses or coverall goggles with clear lenses and Flame Resistant (FR) rated face shield with a clear or amber lens may be worn.

## **5. Hand and Foot Protection**

### **(a) Hand Protection**

- (1) When employee's hands are exposed to hazards such as those from skin absorption of harmful substances, cuts or lacerations, abrasions, punctures, chemical burns, thermal burns, radioactive materials, and harmful temperature extremes they shall use Company-provided gloves.
- (2) Hand protection, such as gloves, shall not be worn where there is a danger of the hand protection becoming entangled in moving machinery or materials

- (2) Employees shall use the following types of gloves when working on or near energized conductors or apparatus:

<b>Maximum Use Voltage</b>		<b>Glove Type</b>
<b>Phase-to-Phase</b>	<b>Phase-to-Ground</b>	
50 to 500 volts AC (nominal); 50 to 750 volts DC	50 to 500 volts AC (nominal); 50 to 750 volts DC	Class 00 rubber gloves with leather keepers
5,000 volts	2,400 volts	Class 2 rubber gloves with leather keepers
21,000 volts	17,000 volts	Class 2 rubber gloves with leather keepers <i>(rubber glove certified employees only)</i>

New rubber gloves must have been electrically tested within the previous 12 months before being placed in service. Gloves may not remain in service for more than 6 months without an electrical retest. 00 Gloves must be given the required air test (CSP Rule 412) before each use.

**(b) Foot Protection**

Appropriate foot protection shall be required for employees who are exposed to foot injuries from electrical hazards, hot, corrosive, poisonous substances, falling objects, crushing or penetrating actions, which may cause injuries or who are required to work in abnormally wet locations.

Choosing the right foot protection for the work is critical. The optimal foot protection is work boots made of leather. Work boots should be laced up and cover the ankles to provide adequate foot and ankle support. Slip on boots or boots with “man-made” materials do not offer optimal foot protection for many of the tasks performed in the field. Slip on work boots, do not provide support for the ankle and man-made materials can allow outside liquids to pass into the work boot. When selecting work boots, choose the boot that is optimal for the work you are performing or follow organizational guidelines, if established.

- (1) Employees shall wear Company-provided toe guards when using power tampers, pavement breakers, jackhammers or other equipment that could result in crushing injuries to the feet.

Gas Exception:

Toe guards are not required while working in excavations with a clay spade.

- (2) Employees shall wear footwear appropriate for work activities involving chemicals, heavy work, welding or cutting uneven surfaces, slippery floors, frequent walking, etc. There

are many styles of foot wear required for the various trades in the utility. Make sure you select footwear that fits correctly, is comfortable to wear for long periods of time, and provides ankle support. Lace up boots, rather than slip on, offer optimal support for both the foot and ankle. While each individual is different, making the best selection for the work being performed, safety while performing that work, fit, comfort and support provides the best foot wear.

- (3) When working on or near exposed live parts, only work shoes with hard rubber soles and leather uppers are permitted. Tennis shoes or shoes that have non-natural fabrics on the uppers or flammable man-made materials are not permitted. **NOTE:** Small amounts of winter lining are permitted to extend out the top of the upper boot.
- (4) Open toe shoes, sandals, flip flops, are not permitted in the field environment. While shoes of these types can be worn in an office setting, it is best to wear “closed-toe shoes” to protect your toes/feet in any environment.

## 6. Noise Control

- (a) Employees who may be exposed to noise above 85 dBA for short periods of time and/or who voluntarily use hearing protection shall attend hearing protection and conservation training in accordance with SAFE-2003S – Noise Control Standard. These employees will not be offered audiometric testing unless they meet the criteria in (b).



- (b) Employees exposed to noise at or above the action level (PEL: an 8-hour time-weighted-average [TWA] of 85 decibels [dBA]) shall wear approved hearing protection, participate in annual training, and shall be offered audiometric testing. The identified job classifications are listed in the Noise Control Standard Exhibit A, Targeted Job Classifications.
- (c) Employees shall wear approved hearing protective devices when:
  - (1) Operating tools or equipment that generate noise at 85 dBA or above.
  - (2) Working in areas where signs have been posted indicating that hearing protection shall be worn, or in areas of noise at 85 dBA or above.
  - (3) Working in other areas where the noise level exposure will, or may, equal or exceed 85 dBA.
  - (4) Instructed to do so by the employee-in-charge.
- (d) Employees shall wear two approved hearing protective devices when noise exposure exceeds 100 dBA. Two hearing protective devices include: wearing approved over-the-ear devices (e.g. ear muffs) in addition to wearing approved ear plugs.

## **7. Respiratory Protection**

- (a) Employees shall not wear a respirator until their job task and exposure have been evaluated and the employee has been medically cleared, fit tested, and trained in the proper maintenance, use, limitations, and care of the respirator being worn. Respiratory protection will be used only

---

after engineering and administrative controls have been implemented and were not successful in reducing or eliminating airborne exposures.

- (b) Employees who are or may be exposed to airborne levels of dusts, mists, fumes, gases or vapors at or above the permissible exposure level(s) for the particular contaminant(s) shall wear respiratory protection and participate in the Company's medical surveillance program, and receive annual training and fit testing in accordance with the Company's Respiratory Protection Program (RPP) in SAFE-2006S.
- (c) Respirators shall be selected, provided and worn in accordance with the Company's Respiratory Protection Program (RPP).
- (d) Employees shall only use respirators provided by the Company.
- (e) Anytime they don a respirator, employees shall be clean-shaven where the respirator seals to the face. Clean shaven includes removal of facial hair that would interfere with the function of the respirator valve (i.e., goatee or long mustache). Use of a respirator is prohibited when conditions, such as facial hair, prevent a good seal of the respirator.
- (f) Voluntary Respirator Users: Employees who opt to wear a respirator in areas where respirators are not required shall have the approval of their Supervisor and the Site Administrator for the organization's RPP and comply with program elements of the RPP, including medical clearances. **Exception:** Use of dust masks.

**8. Fall Protection**

- (a) Employees who are exposed to fall hazards greater than 6 feet or 4 feet above the ground on poles, towers or similar structures shall attend training on proper fall protection methods before such work is performed and shall act in accordance with the Company's Fall Protection Standard (SAFE-1012S).
- (b) Employees shall use approved harnesses and lanyards, approved ropes/cables, life lines, temporary guard railings, or other adequate protection as required when working in elevated positions such as rope access, work at heights greater than 6 feet or 4 feet above the ground on poles, towers or similar structures (including trenches or excavations over 6 feet deep), and erecting and dismantling scaffold.
- (c) All Fall Protection Equipment including but not limited to primary positioning straps and secondary positioning straps (flip lines) must be inspected each day before use to determine that they are safe. Lineman positioning straps shall not be used when the red safety marker strip is exposed. In addition, all Fall Protection Equipment shall be inspected and documented twice a year by a Competent Person. .
- (d) Any Fall Protection Equipment that fails inspection must be removed from service and destroyed.
- (e) Any job plan that involves working at heights must include a rescue plan.
- (f) Tools and other materials shall not be left lying in elevated work areas unless prevented from falling.

**9. Scaffolds and Falsework**

- (a) No employee, material or equipment shall be supported on any portion of a tree, pole, structure, scaffold, ladder, walkway or other elevated structure, crane or derrick, etc., without it first being determined that such support is adequately strong and properly secured.
- (b) Each scaffold shall be designed and constructed using a dead load safety factor that will ensure the scaffold supports, without failure, its own weight and 4 times the maximum intended working (live) load applied or transmitted to it
- (c) Erection and dismantling of scaffolding and false work shall be performed under the supervision and direction of a scaffold Qualified Person.
- (d) Scaffolds that are in service shall be inspected daily by a scaffold Qualified Person.
- (e) Tools and other materials shall be kept in a tool bag or secured from falling.

**10. Ladders**

- (a) Prior to using a ladder, employees shall receive ladder safety training and use Company approved ladders.
- (b) Employees shall:
  - (1) Inspect the ladder prior to each use.
  - (2) Not use ladders that are damaged or deteriorated.
  - (3) Use a ladder appropriate to the job and location.
  - (4) Place ladders on a base that is solid, even, and free of water, grease or other slip hazard, where possible, and securely place, hold, tie, or otherwise make the ladder secure to prevent slipping or falling.

- (5) Not place ladders or stools on grating unless legs are thick enough to prevent legs from falling through the grating openings.
- (6) Not place a ladder in front of doors opening toward ladder unless the door is open, locked, or guarded.
- (7) Face the ladder and use both hands when ascending or descending (maintaining three points on contact with the ladder at all times).
- (8) When working from a ladder, the ladder must be adequately secured.
- (9) Not stand on the top platform of stepladders unless specially constructed for this purpose and there are members of the structure that provide a firm handhold.
- (10) Not use benches, boxes, tables or other makeshift substitutes as ladders or use the ladder as part of a makeshift scaffold or ramp.
- (11) Not carry equipment or materials that prevent safe use of the ladder or leave tools or equipment unattended on the ladder.
- (12) Not use a ladder if the job involves the use of many tools or materials or excessive amounts of force, or if the job takes a long time to complete.
- (13) Observe the following working load (worker, materials and equipment) limitations for ladders:

<b>Duty Rating</b>	<b>Ladder Type</b>	<b>Working Load (lbs)</b>
Special Duty	IAA	375
Extra Heavy-Duty	IA	300
Heavy-Duty	I	250
Medium-Duty	II	225
Light-Duty	III	200

- (c) When using straight or extension ladders:
- (1) Non-self-supporting ladders such as single ladders and extension ladders shall, where possible, be used at such a pitch that the horizontal distance from the top support to the foot of the ladder is one-quarter of the working length of the ladder (the length along the ladder between the foot and the top support)
  - (2) The side rails shall extend at least 36 inches (3 feet) above the landing (overlap depends on ladder length). If this is not practical, grab rails that provide a secure grip for an employee moving to or from the point of access shall be installed.
  - (3) Do not lean ladder against a pole or other single top support unless there is a top rest that is rigid and has ample strength.
- (d) Portable ladders shall:
- (1) Be equipped with nonslip bases. This does not include special purpose ladders, such as tower ladders and metal manhole ladders.

- (2) Be blocked, lashed or held, as required, when placed upon oily, metal, or concrete surfaces.
  - (3) Not be used in the vicinity of electric circuits if they are made of metal. Metal ladders shall be legibly marked "Caution-Do Not Use Around Electrical Equipment."  
**Exception:** Non-conductive fiberglass railed ladders may be used in the vicinity of electrical circuits.
- (e) Wooden ladders shall only be finished with clear shellac, varnish or other clear finish. Paint shall not be used on wooden ladders.

## 11. Clothing and Jewelry

- (a) Employees shall wear suitable clothing at all times to minimize danger when they are exposed to live electrical equipment or lines, moving machinery, hot surfaces or substances, potentially injurious substances, rough or sharp surfaces, open flames, explosions, etc.
- (1) Clothing considered suitable for working on or around open flames is clothing that is made from 100% natural fiber (e.g., cotton, wool or leather). If the worker's job classification requires work on energized exposed electric conductors, and/or equipment energized at 50 volts or greater which have the potential for an unexpected arc, the clothing must be of Company approved flame resistant (FR) material. If the worker's job classification requires FR clothing, all other outer garments (i.e., jackets, coats, rain gear, etc.) shall also be FR rated in accordance with SH&C



Procedure 237. Traffic vests, disposable coveralls or other protective layers which are worn over FR clothing can be made of flame retardant material.

- (2) FR clothing worn must be arc rated at a level suitable for the activity being performed in accordance with departmental specific guidelines and must meet one of the following levels:
  - a. Single-Layer Flame Resistant (SLFR): FR long-sleeved shirt and FR pants, approved by the Company, with a minimum rating of 8 cal/cm<sup>2</sup>.
  - b. Double-Layer Flame Resistant (DLFR): Company approved SLFR clothing plus an approved FR coverall, and level 2 FR face protection. This clothing system must be approved by the Company and have a minimum rating of 25 cal/cm<sup>2</sup>. See CSP Rule 4 (c).
  - c. Suited: Protective switching suits rated a minimum of either 50 cal/cm<sup>2</sup> or 100 cal/cm<sup>2</sup>. Required ratings will be designated by Suited50 and Suited100 respectively. Protective switching suits require the use of Class 2 high voltage lineman's rubber gloves with leather protectors.
- (b) Jewelry shall not be worn where there is a danger of electrical contact, crushing injuries, or snagging on machinery, materials, or other objects or when working on or adjacent to energized conductors or apparatus. Examples include but are not limited to: rings, ear rings,

body piercings, watch chains, wrist bands, key chains, exposed neck chains, tie chains, clasps and medical alert jewelry.

**12. Hazard Communication**

- (a) Before performing work that requires handling chemicals, employees shall attend training in accordance with the Company's *Hazard Communication Standard (Safe-2002S)* and thoroughly familiarize themselves with the hazards involved; safe handling practices, including proper selection and use of personal protective equipment; proper storage; and spill and disposal procedures.
- (b) Before handling a chemical, employees shall follow work practices, and utilize precautions and protective devices and/or equipment as identified on the label, the safety data sheet (SDS) or by the supervisor. Employees with open wounds that cannot be covered with approved PPE shall not use chemicals.
- (c) Employees shall keep food stored in a separate location from hazardous substances. After handling hazardous substances, employees shall thoroughly wash their hands before eating, drinking, smoking, or applying cosmetics.
- (d) Employees shall only use chemicals that have been reviewed and approved for use by Environmental and Safety.

**13. Flammable Liquids**

- (a) Employees shall handle, store and transport flammable liquids only in approved containers. Extreme care shall be used at all times to prevent ignition.

- (1) Do not transport approved containers inside a vehicle. Containers shall be adequately secured and transported in a tool bin.
- (b) To minimize the hazard from static electricity, employee shall maintain an electrical contact between the pouring and receiving containers when pouring or pumping flammable liquids from one container to another.
- (c) Employee shall comply with local ordinances and/or other regulatory agency requirements concerning the handling and storage of flammable liquids.
- (d) Employee shall not use equipment which is leaking flammable liquid.

**14. Fire Protection**

- (a) Employees shall be familiar with the local emergency plan and the instructions relating to fire prevention and suppression, and with the location and use of fire-fighting equipment in the location where they are regularly employed.
- (b) Fire-fighting apparatus shall be maintained in serviceable condition and accessible at all times.
- (c) Employees expected to use fire extinguishers or other firefighting equipment shall receive training prior to their use.

**15. Compressed Gases****(a) General**

- (1) The contents of gas cylinders shall be clearly marked on a label, stencil or tag. Unmarked cylinders shall not be used.
- (2) Leaking or unserviceable cylinders shall be marked or tagged as such and the vendor promptly notified.

- (3) To minimize explosion hazard, oil or grease shall not be allowed to come in contact with valves, regulators, or any other parts of oxygen cylinders or apparatus.
  - (4) Employees shall use only cylinders that have a current hydrostatic test date.
  - (5) Pressure relief devices and regulators shall be used in accordance with the manufacturer's recommendations and shall not be changed, modified, tampered with, obstructed or repaired.
- (b) **Use and Storage**
- (1) Fuel-gas shall not be used from cylinders through torches or other devices equipped with shutoff valves without reducing the pressure through a suitable regulator attached to the cylinder valve or manifold.
    - (2) Connections to piping, regulators, and other appliances shall be kept tight to prevent leakage. If leaks develop, never test with an open flame. Use soap solution or other leak test solution. if leak is suspected.
  - (3) Portable gas cylinders or containers shall be handled with extreme care and shall be stored in a suitable, well ventilated location and properly secured with one or more restraints to a fixed object. The cylinder or container shall be in a vertical position with valve cap in place.
  - (4) Cylinders shall not be placed where they might become part of an electrical circuit.
  - (5) Cylinders shall not be stored near elevators, gangways, unprotected platform edges, or

where heavy objects might strike or fall on them.

- (6) Portable gas cylinders or containers shall not be exposed to excessive heat. Sparks and flames shall be kept away from such cylinders or containers.
  - (7) Oxygen cylinders in storage shall be separated from fuel-gas cylinders or combustible materials (especially oil or grease), a minimum distance of 20 feet or by a noncombustible barrier at least 5 feet high having a fire-resistance rating of at least one-half hour.
  - (8) When cylinders or containers are not in use, valves shall be kept tightly closed.
  - (9) Compressed oxygen shall never be used as a substitute for:
    - a. Compressed air
    - b. Dry breathable air.
  - (10) Compressed air or other gas in excess of 10 pounds per square inch (psi) shall not be used to blow dirt, chips or dust from clothing while it is being worn.
- (c) **Transportation**
- (1) Compressed gas cylinders shall be transported in a manner to prevent them from falling, rolling or creating a tripping hazard. Liquefied petroleum gas and welding fuel gas cylinders shall be stored and/or transported in an upright position so that the safety relief valve is always in direct contact with the vapor space in the cylinder. Unless cylinders are secured on a suitable truck, rack or container, regulators shall be

removed and valve protection devices (valve cap) installed before cylinders are moved.

- (2) When transporting compressed gas cylinders "in portable service," a suitable truck, equipped with the means to substantially secure the cylinder(s) and/or racks to the transport vehicle, shall be used. Pressure regulating devices may remain in place during transportation of compressed gas cylinders used in portable service.

## 16. Lights

- (a) Employees shall not use artificial light near escaping gas, gasoline, or other flammable vapors, or when entering a room or enclosure suspected of containing combustible gases.  
**Exception:** Approved explosion-proof electric flashlights or explosion-proof extension cords and fixtures (such device shall be UL/FM-approved and marked "explosion-proof") may be used in these circumstances.
- (b) Employees shall not enter dark places, such as basements, cellars, etc., without proper light; the use of matches or other open flames is strictly forbidden.

## 17. Welding, Cutting, Metalizing, Soldering, and Use of Open Flames

- (a) All employees who perform and support welding, cutting and grinding operations shall be properly instructed and judged competent to operate such equipment and be trained in the safe use of the process in accordance with the Company's Welding, Cutting, and Grinding Standard (SAFE-1013S).

- 
- (b) A hot work permit is required prior to any welding or other hot work such as brazing, cutting and grinding that may produce sparks, slag or flames. Prior to filling out a hot work permit, a work area assessment must be completed. The hot work permit must include:
- (1) The effective time and date.
  - (2) The place of use.
  - (3) The hours during which the source of ignition may be used, not to exceed 24 hours.
  - (4) The specific location or piece of equipment where the source of ignition will be used.
  - (5) The nature of the use of the source of ignition.
  - (6) Any special precautions or limitations to be observed before, during or after the use of the source of ignition, including the need for fire watch.
- (c) Open flames shall not be brought near - nor shall welding processes, brazing, flame cutting, or soldering be performed on - an empty container, tank, or other vessel that has, or may have, previously contained a flammable or explosive substance until the following precautions are taken to prevent explosion or fire:
- (1) Fill container or vessel with water or inert gas, such as carbon dioxide or nitrogen **OR** clean the inside with steam, caustic solution, or sandblasting
  - (2) Remove residue or other flammable material from the work area **OR** perform work with an observer who is equipped with proper fire extinguishing devices.



- (3) If the container is filled with inert gas, then also provide means to prevent air from entering the vessel while work is in progress.
- (d) Welding processes may be performed on the outside surface of a container, tank, or other vessel containing a liquid flammable material, provided the work is done not less than 3 feet below the level of the liquid, and there is little likelihood of burning through the vessel wall. Adequate venting to preclude internal pressure buildup shall be provided as required.
- (e) Welding processes may be performed on the top surface of a vessel that is partially filled with a liquid flammable material that cannot be removed (except LPG vessels), only after the area above the liquid is filled with steam, carbon dioxide, or other inert gas and the vessel is held under positive pressure.
- (f) Welding processes, flame cutting, brazing, metalizing, soldering, and the use of open flames on vessels subject to possible ignition of contents, shall be done in accordance with approved procedures by Qualified Persons who shall observe the following additional precautions:
  - (1) Keep as far away from vessel opening as possible
  - (2) Provide suitable fire protection equipment adjacent to the work
  - (3) Hazardous areas shall be designated by signs and protected by approved barricades as required.
- (g) It shall be the responsibility of the welder to see that, where practical, screens are properly placed

to prevent fires and eye injury to fellow workers and onlookers. Employees assisting the welder shall wear suitable eye protection.

- (h) Welding, brazing, and cutting operations inside buildings shall use local exhaust ventilation (LEV) systems supplying a minimum air velocity of 100 linear feet per minute in the welding zone.
- (i) LEV shall be used when potentially hazardous materials are employed as base metals, fluxes, coatings, plating or filler metals during welding, cutting or brazing in an enclosed space. These include, but are not limited to, the following materials:
  - Beryllium
  - Cadmium
  - Chromium
  - Fluorides
  - Lead
  - Mercury
  - Inert-gas metal-arc welding or oxygen cutting of stainless steel
  - Zinc

The following additional precautions shall be observed:

- (1) Sufficient ventilation shall be provided for the protection of others to prevent accumulation of harmful quantities of fumes in the work area, or
- (2) The operation shall be isolated, or
- (3) The work shall be performed outdoors in such a location that fumes will not enter any building in harmful quantities.

If LEV cannot reduce the airborne concentrations of these compounds to below the respective permissible exposure limits (PELs), then supplied-air respiratory protection will also be used.

- (j) Respiratory protection shall be used when welding, cutting, or brazing operations are performed outside and involve exposure to beryllium, lead, cadmium, mercury, zinc, chromium, fluorides, or inert-gas metal-arc welding or oxygen cutting of stainless steel .
- (k) In all operations involving beryllium-containing base or filler metals, supplied air respirators shall be used.
- (l) When performing repairs or alterations on chemical or fuel piping, a Qualified Person shall be accountable for the work to see that proper precautions to prevent explosion or fire are observed and procedures applicable to the use of special apparatus to affect such repairs or alterations are followed.
- (m) The use of open flames or other sources of ignition in battery rooms is prohibited except under the direct supervision of a Qualified Person, and then only after the room has been well ventilated.
- (n) Coatings on pipes and other surfaces (e.g., paint, etc.) shall be removed mechanically, or by other safe means, before welding. Coatings shall not be burned off with a torch.

**18. Heat Illness Prevention****(a) Drinking water**

- Employees shall have access to potable drinking water.
- The water must be fresh, pure, and suitably cool.
- The water shall be located as close as practicable to the areas where employees are working. Where drinking water is not plumbed or otherwise continuously supplied, it shall be provided in sufficient quantity at the beginning of the work shift to provide one quart per employee per hour for drinking for the entire shift.
- The shift can begin with smaller quantities of water if effective procedures are in place for replenishment during the shift as needed to allow employees to drink one quart or more per hour.
- Frequent drinking of water shall be encouraged.

**(b) Shade**

- Shade shall be present when the temperature exceeds 80 degrees Fahrenheit.
- When the outdoor temperature in the work area exceeds 80 degrees Fahrenheit, there must be one or more areas with shade at all times while employees are present that are either open to the air or provided with ventilation or cooling.
- The amount of shade present shall be at least enough to accommodate the number of

employees on recovery or rest periods, so that they can sit in a normal posture fully in the shade without having to be in physical contact with each other.

- The shade shall be located as close as practicable to the areas where employees are working.
- The amount of shade present during meal periods shall be at least enough to accommodate the number of employees on the meal period who remain onsite.
- Shade shall be available when the temperature does not exceed 80 degrees Fahrenheit. When the outdoor temperature in the work area does not exceed 80 degrees Fahrenheit.
- Employees are allowed and encouraged to take a preventative cool-down rest in the shade when they feel the need to do so to protect themselves from overheating. Access to shade shall be permitted at all times.
- An individual employee who takes a preventative cool-down rest :
  - Shall be monitored and asked if he or she is experiencing symptoms of heat illness;
  - Shall be encouraged to remain in the shade; and
  - Shall not be ordered back to work until any signs or symptoms of heat illness have abated, but in no event less than 5 minutes in addition to

the time needed to access the shade.

- If an employee exhibits signs or reports symptoms of heat illness while taking a preventative cool-down rest or during a preventative cool-down rest period, appropriate first aid or emergency response shall be in place.
- Exceptions:
  - When it can be demonstrated that it is infeasible or unsafe to have a shade structure, or otherwise to have shade present on a continuous basis, alternative procedures for providing access to shade can be in place.
- Cooling measures other than shade (e.g., use of misting machines) may be provided in lieu of shade if these measures are at least as effective as shade in allowing employees to cool.

(c) High-heat procedures

- High-heat procedures shall be implemented when the temperature equals or exceeds 95 degrees Fahrenheit. These procedures shall include the following:
  - Ensure that effective communication is maintained so that employees at the work site can contact a supervisor when necessary.

- Observe employees for alertness and signs or symptoms of heat illness.
- One of more of the following observation/monitoring must be implemented:
  - Supervisor or designee observation of 20 or fewer employees, or
  - Mandatory buddy system, or
  - Regular communication with sole employee such as by radio or cellular phone, or
  - Other effective means of observation.
- Designating one or more employees on each worksite as authorized to call for emergency medical services, and allowing other employees to call for emergency services when no designated employee is available.
- Reminding employees throughout the work shift to drink plenty of water.
- Tailboard to review the high heat procedures, encourage employees to drink plenty of water, and remind employees of their right to take a cool-down rest when necessary.

---

**(d) Emergency Response Procedures**

- The following emergency response procedures shall be implemented:
  - Ensure that effective communication is maintained so that employees at the work site can contact a supervisor or emergency medical services when necessary.
  - Respond to signs and symptoms of possible heat illness, including but not limited to first aid measures and how emergency medical services will be provided.
- If a supervisor observes, or any employee reports, any signs or symptoms of heat illness in any employee, the supervisor shall take immediate action commensurate with the severity of the illness.
- If the signs or symptoms are indicators of severe heat illness (such as, but not limited to, decreased level of consciousness, staggering, vomiting, disorientation, irrational behavior or convulsions), emergency response procedures must be implemented.
- An employee exhibiting signs or symptoms of heat illness shall be monitored and shall not be left alone or sent home without being offered onsite first aid and/or being provided with emergency medical services in accordance with SAFE-2001S Heat Illness Prevention Standard.
- Contacting emergency medical services and, if necessary, transporting employees to a



place where they can be reached by an emergency medical provider.

- Ensuring that, in the event of an emergency, clear and precise directions to the work site can and will be provided as needed to emergency responders.

(e) Acclimatization.

- All employees shall be closely observed by a supervisor or designee during a heat wave.
  - A “heat wave” means any day in which the predicted high temperature for the day will be at least 80 degrees Fahrenheit and at least ten degrees Fahrenheit higher than the average high daily temperature in the preceding five days.
- An employee who has been newly assigned to a high heat area shall be closely observed by a supervisor or designee for the first 14 days of the employee's employment.

(f) Training

- All employees who work outdoors, and all supervisory employees who oversee those working outdoors are required to take SAFE-0615 Heat Illness Prevention Training

---

(g) Heat Illness Prevention Plan

- The company plan SAFE-2001S Heat Illness Prevention Standard shall be made available at the worksite to employees

**19. Smoking**

- (a) Employees shall not smoke in proximity to flammable liquids, explosives, or gases, or where “No Smoking” signs are displayed.
- (b) Matches, cigars, cigarettes, tobacco, or other substances shall not be discarded while still burning except when placed in a proper receptacle or otherwise disposed of safely.
- (c) No employee shall have matches or other sources of ignition on his/her person when entering an explosive or combustible area.
- (d) Smoking shall not be permitted in areas indicated as danger zones or areas closed by federal, state, county, or city officials.
- (e) When hydrogen-filled equipment, such as generators and synchronous condensers, are out-of-service for overhaul, smoking or open flames shall not be permitted around the unit until all hydrogen has been purged from the equipment and the unit is declared safe to enter. Smoking or open flames shall not be permitted while filling the equipment with hydrogen. The area around the equipment shall be roped off and plainly marked and posted with approved signs during these operations.
- (f) PG&E does not allow smoking in buildings, places of employment, or other enclosed workplaces and as directed by state and local

---

law. As a result, employees who wish to smoke must exit the buildings to do so. As a courtesy to these employees, the Company often makes ashtrays and other amenities available in an outdoor area. Such locations balance the needs of our smoking and non-smoking employees. So long as others are not obliged to walk through the smoking area, these locations do not require any warning notices. However, when these informal smoking areas are in the immediate vicinity of the entrance to Company facilities (such as in a courtyard or patio area or Company-owned walkway outside the door to the lobby, or adjacent to the main office trailer), Proposition 65 requires us to warn anyone walking through that area of the presence of tobacco smoke before they are exposed to it.

While a Proposition 65 sign could be posted to accomplish this warning, it is recommended that you prohibit smoking in locations immediately adjacent to the public access points to our buildings. This can be accomplished by clearly posting No Smoking signs in the area around the public entrances, and by assuring that ashtrays or other amenities that signal smoking is permitted are not placed adjacent to the building entry points. The goal is to make it possible for someone to enter or exit the building without having to be exposed to second-hand tobacco smoke. Please note that when access to the building is directly off a public right-of-way (such as a public sidewalk) there is no need to post signs, however ashtrays or other indications that smoking is permitted should not be placed at

these locations. A variety of No Smoking signs are available through E-Buy. Should you choose to permit smoking in public access areas, you may procure an approved Proposition 65 sign warning about the presence of tobacco smoke through SRM under part number P65-TOB-PGE.

- (g) TRAN-1002S – Assignment and Personal Use of Company Vehicles Standard, indicates specific requirements that are prohibited when operating any Company passenger or work vehicle. These requirements include “any personal use that would likely damage the vehicle or cause discomfort for those later using the vehicle, such as smoking in the vehicle.” As such, Smoking is never permitted in Company passenger or work vehicles under any circumstances.

## 20. **Confined Spaces**

### (a) **Other Confined Spaces:**

Construction activities, natural gas utility vault operation, electric utility vault operations, and telecommunication vault operations.

- (1) Examples of Other Confined Spaces may include: silos, tanks, vats, vessels, boilers, compartments, ducts, sewers, pipelines, vaults, bins, tubs, and pits, excavations, underground electric gas and telecommunication vaults, manholes.

Spaces that have the concurrent existence of the following conditions are considered “Other Confined Spaces” (OCS):

- a. Existing ventilation insufficient to remove dangerous air contamination and/or oxygen enrichment or oxygen deficiency that may exist or develop.

**Dangerous air contamination** is an atmosphere presenting a threat of causing death, injury, acute illness, or disablement due to the presence of flammable and/or explosive, toxic, or otherwise injurious or incapacitating substances.

- b. Ready access or egress for the removal of a suddenly disabled employee is difficult due to the location and/or size of the opening(s).
- (2) Employees who enter an Other Confined Space (OCS) shall follow SAFE-1019S Other Confined Space Standard and their department's written operating and rescue procedures and attend OCS training before they enter an OCS. Entry is defined as any time in which the entrant's breathing zone (i.e., an entrant's face, mouth and/or nose) breaks the plane of the opening into the space
- (b) **Permit Required Confined Spaces (PRCS)**
- (1) A confined space for Company work operations and locations not listed in 20(a) that has all three of the following conditions:
    - a. Large enough and so configured that an employee can bodily enter and perform assigned work
    - b. Limited or restricted means for entry or exit
    - c. Not designed for continuous employee occupancy.

- (2) A Permit Required Confined Space is a confined space [as defined in 20(b)(1)] that also has one or more of the following characteristics:
- a. Contains or has the potential to contain a hazardous atmosphere. An atmosphere is hazardous if it may expose an employee to the risk of death, injury, acute illness, incapacitation, or impair the ability to escape unaided from the space from one or more of the following causes:
    - 1) Flammable gas or vapor exceeding 10% of its LEL
    - 2) Oxygen levels below 19.5% or above 23.5%
    - 3) Combustible dust at or above its Lower Flammable Limit (LFL)
    - 4) An airborne substance exceeding its Permissible Exposure Limit (PEL)
    - 5) Any other atmospheric condition that is considered to be immediately dangerous to life or health (IDLH).
  - b. Contains a material that has the potential for engulfing the entrant
  - c. An internal configuration such that an entrant could be trapped or asphyxiated by inwardly converging walls or by a floor that slopes downward and tapers to a smaller cross-section
  - d. Any other recognized serious safety or health hazard such as mechanical or

electrical equipment that, if energized or contacted, could cause serious injury.

- (3) A Qualified Person shall evaluate every confined space to determine if it is a PRCS.
  - (4) Employees who enter a PRCS (i.e., any part of the body breaks the plane of the opening) shall follow SAFE-1006S Permit Required Confined Space Standard and their department's written PRCS program and attend PRCS training before entering a PRCS or being assigned to a PRCS work team.
  - (5) Employees shall identify and evaluate the hazards associated with entering a PRCS prior to entry. Posted signage shall be taken into account to identify the PRCS and ensure that all PRCS procedures are followed when entering the space.
  - (6) Employees who work in PRCS owned by another organization must be trained in and follow that organization's PRCS program.
- (c) Confined Spaces in Construction (CSC)**
- (1) Employees engaged in construction activities at a worksite with one or more confined spaces must comply with CSC. The requirements set forth in this section and in Other Confined Spaces must be followed concurrently if construction activities are performed in a confined space.
  - (2) Before it begins work at a worksite a competent person shall identify all confined spaces in which one or more of the employees it directs may work, and identifies each space that is a permit space, through consideration

and evaluation of the elements of that space, including testing as necessary.

- (3) If the workplace contains one or more permit spaces SAFE-1035S Confined Spaces in Construction shall be followed.

## 21. Water Safety

- (a) Employees swimming or wading in water that may be deep or dangerous, working near dock edges, walkways, or other locations where it is possible to fall into the water, without railings, nets or safety belts shall wear a Coast Guard-approved life vest, or a safety strap or lifeline that is adequately secured.
- (b) Employees working from, or traveling in, boats or other watercraft shall wear a Coast Guard-approved life vest.
- (c) If employees are protected from falling into the water by suitable hand railing, bulkheads, or the equivalent, no life vest or fall protection is required.

**Note:** The requirements for wearing life vests or lifelines do not apply when engaged in authorized diving activities.

- (d) At least one U.S. Coast Guard approved 30-inch life ring with not less than 150 feet of 600 pound capacity line attached shall be kept in a conveniently accessible place where employees work exposes them to the hazard of drowning or each employee so exposed shall wear a U.S. Coast Guard approved personal flotation device.
- Exception:** Flume Patrol. Flumes provided with caps
- (e) Any personal flotation device shall be approved by the United States Coast Guard as a Type I



PFD, Type II PFD, Type III PFD, or their equivalent, pursuant to 46 CFR 160 (Coast Guard Lifesaving Equipment Specifications) and 33 CFR 175.23 (Coast Guard table of devices equivalent to personal flotation devices.)

- (f) Personal flotation devices shall be maintained in good condition. They shall be removed from service when damaged so as to affect their buoyant properties or capability of being fastened.

**Weather:**

Before you begin work on boats, check the local “weather and sea” conditions. Detailed information can be obtained by tuning in to local radio stations or the National Weather Radio broadcasts on frequencies of 162.400, 162.475, and 162.550 MHz in areas where available, or by consulting local newspapers.

**Training:**

Company requires that any operator of any rented or owned company boat take and successfully pass a Boating Safety Course approved by California Department of Boating and Waterways (CDBW). The CDBW offers a boating course at no charge.

**Fueling:**

Most fires happen after fueling. To prevent fires:

- Don't smoke or strike matches.
- Shut off motors.
- Turn off electric equipment.
- Close all windows, doors and openings.
- Take portable tanks out of the boat and fill them on the dock.

- Keep the filling nozzle in contact with the tank.
- Wipe up any spilled gas with petroleum-absorbent pads.
- Discard the pads in a safe manner.
- Ventilate for at least five minutes.
- Make sure there is no odor of gasoline anywhere in the boat.
- Periodically check the system for fuel leaks.
- Visually check for leaks or fuel in the bilges.

**Boat Capacity**

Single-hull motorboats less than 20 feet in length which are manufactured after 1972 must display capacity and safe horsepower information. The maximum weight in persons, gear and motors is offered as a guide to boaters, and should not be exceeded.

**Loading**

It's the operator's responsibility that supplies be carefully loaded and all passengers be properly seated. Spread weight evenly. Fasten gear to prevent shifting. Keep passengers seated. Don't overload.

**Before embarking:**

Develop and communicate to all passengers the "Float Safety Plan" (route, communication devices, job task, PPE, emergency response, etc.)

Give consideration to basic safety items, including the following:

- Vessel in good condition
- Tools

- Vessel properly loaded
- Extra starting battery
- Ample supply of fuel
- Personal flotation devices
- Check weather reports
- Compass and charts
- Fire extinguisher
- Good anchoring equipment
- Bailing Device
- Visual distress signals
- Spare parts
- Oars or paddles
- First-aid kit
- Marine VHF radio
- Flashlight

**22. Electrical Hazards**

- (a) Electrical apparatus and lines shall be considered energized until they have been tested de-energized, grounded, or cleared as required by a Qualified Electrical Worker (QEW).
- (b) Employees shall not perform work or take a conducting object closer than the minimum approach distance or within the area where there exists a hazard of creating an arc, or of contact with energized equipment by reason of the work being done unless that person is qualified and using approved equipment and work procedures or unless directly under the observation of a Qualified Electrical Worker.
- (c) All electrical controls, annunciators, alarms, and indicating light circuits in the back of control and gauge boards shall be considered energized. Employees working in back of these boards shall exercise caution against contact with exposed

energized parts. Adequate minimum distances or suitable barriers shall be used to avoid electrical contact. (See CSP Rule 405 for minimum distances.)

- (d) Caution shall be exercised to prevent materials or tools from contacting energized conductors or equipment.
- (e) No material or tools shall be carried on the shoulder when working around energized equipment. Long material, including lumber, shall be carried in a horizontal position.

### **23. Clearances**

Before employees start work on equipment or apparatus for which clearances are required, they shall either obtain a clearance or report to and work under a Qualified Person who holds a clearance on the equipment or apparatus involved.

### **24. Responsibilities for Primary Operations**

#### **(a) Equipment in Service**

Employees shall consider all equipment in-service unless properly tagged (e.g., with "Man on Line" or "Out of Order" tags, etc.). Employees shall inspect all equipment for damage, deterioration and defects prior to use.

Employees shall not assume that untagged equipment is free of hazards.

#### **(b) Clearance Requirements**

Clearance, where required, shall be obtained in accordance with the applicable Company guidance documents.

#### **(c) Employees Operating Equipment**

When employees operate or work on equipment, they shall properly tag the equipment with their

name, location, number and/or other required information. The Employee-in-Charge will verify that equipment is properly tagged.

(d) **Abnormal Operating Conditions**

Employees shall continually evaluate operating equipment to prevent potential hazards to employees and equipment. The evaluation shall include, but not be limited to, excessive temperatures and pressures, over speeding of rotating equipment, abnormal noises, and unusual vibration.

(e) **Records**

Employees shall keep logs and records current and accurate. Abnormal or special conditions shall be called to the attention of the employee-in-charge and shall be logged promptly. Shift employees shall review the records of the previous shift to familiarize themselves with the operations and condition of equipment within their jurisdiction.

**25. “Man on Line” and “Caution” Tags**

- (a) When employees shut down or isolate a section of a main or line, or piece of equipment involved in conveying gas, oil, steam, or high pressure air by closing valves, they shall properly fill out a “Man on Line” tag and place a completed tag on each closed valve or mechanism which constitutes a clearance point.
- (b) Employees shall securely block or otherwise secure prime air movers, machines, or equipment that are capable of movement when there is a possibility of hazard to employees working on them. Lockable controls shall be locked in “off” position during repair work.

Machines not equipped with lockable controls shall be sealed or disconnected from the source of power, or other steps shall be taken which will prevent the prime mover or machine from being started. In addition, "Man on Line" tags shall be placed at these locations.

- (c) Employee shall not remove "Man on Line" tags until work by employees is completed. Tags shall then be removed only under the direction of the employee-in-charge and only after it has been determined that no one is working on the line.
- (d) "Caution" tags shall be used to mark valves or equipment which, for some special reason, shall not be operated except upon specific instructions from the Operating Department or individual named on the tag. This tag shall not be used in place of a "Man on Line" tag.

**26. Cleaning, Repairing, Servicing, Adjusting, and Un-jamming Machinery and Equipment**

- (a) During cleaning, servicing, adjusting, or un-jamming operations, machinery or equipment capable of movement shall be stopped and the power source de-energized or disengaged, and, if necessary, the moveable parts shall be mechanically blocked or locked out per established clearance procedures to prevent inadvertent movement unless the machinery or equipment must be capable of movement during this period in order to perform the specific task. If so, appropriate tools shall be used (e.g., extended swabs, brushes, scrapers) or other methods or means employed to protect employees from injury due to such movement.

- (b) Prior to de-energizing equipment/machinery, all employees working on or with the equipment shall be notified.

**27. Reserved**

**28. Machine Guards**

- (a) Do not operate equipment without suitable machine guards in place.
- (b) Where regular safeguards are removed, employee shall replace or install suitable temporary guards before returning equipment to normal operation.
- (c) Employees shall inspect each safeguard before each use.

**29. Tools and Equipment**

- (a) Employees shall inspect tools and equipment for damage, deterioration and defects prior to use and periodically during the duration of the job, and use only those in good repair. Employees shall report damage, deterioration or defects to their supervisor.
- (b) Employees shall not use damaged or defective tools or equipment but shall tag them and take them out of service until repairs can be made.
- (c) Employees shall use tools and equipment for the task for which they were designed, and use, store and maintain them in accordance with manufacturer's instructions or directions.
- (d) Proper handles shall be fitted to tools where required.
- (e) Cutting tools shall be kept properly sharpened and cutting edges guarded with scabbards (sheaths) or other safe storage provided when not in use.

- (f) Metallic tapes or metallic rules shall not be used near exposed, energized electrical equipment. Cloth tapes with metal reinforcing shall not be used under any circumstances.

**30. General Office Work**

- (a) Chairs, wastebaskets, cords, and other articles shall not be left in aisles or where they constitute a tripping hazard.
- (b) Desk and file drawers, cabinet doors, and slides shall not be left standing open while unattended.
- (c) Common or sharp-pointed pins shall not be used for fastening papers together. Staples, clips, or other approved fasteners shall be used.
- (d) Broken glass or other sharp-edged objects shall not be placed in wastebaskets unless properly protected. Toner cartridges shall be recycled.
- (e) Employees may only work on mechanical office equipment to the extent they have been trained to do so.
- (f) Approved ladders or other safe supports shall be used to reach material on high shelves or at other elevated positions.

**31. Ergonomics**

**(a) Individual Employee Responsibilities**

Employees shall participate in biennial ergonomics training and tailboard discussions in order to apply ergonomic practices to their daily work activities. Employees shall be able to identify ergonomic risks and apply preventive ergonomic principles when exposed to repetition, high forces, awkward positions and static loading. These include proper body mechanics, taking breaks, using proper tools and asking for



help when moving heavy loads or when applying high forces.

(b) **Field Employees:**

- (1) When handling or transferring heavy loads, employees shall work within their physical capabilities and practice proper material handling techniques. Mechanical or additional co-worker assistance shall be utilized when lifting heavy or awkward loads.
- (2) Employees shall report suspected ergonomic hazards to their supervisor and/or safety teams as soon as possible
- (3) Employees shall report early signs of discomfort (e.g., fatigue, soreness, aching, pain) to their immediate supervisor as soon as it is noticed.
- (4) Employees are responsible to be aware of and utilize PPE appropriate for the task such as hand and knee protection.
- (5) Employees shall assume responsibility for appropriate task specific warm-up prior to strenuous work and apply compensatory stretching following prolonged awkward postures.

(c) **Office Employees:**

- (1) Employees shall complete a self-assessment/training WBT according to their Department Ergonomics Plan.
- (2) Employees shall apply ergonomic practices to their daily work activities and request assistance through their supervisor whenever they cannot resolve issues themselves.

- (3) Employees shall report work related discomfort (e.g., fatigue, soreness, aching, pain) to their supervisor in its early stage to prevent injury.
- (4) Employees shall utilize micro breaks and practice break behaviors which provide relief from repetitive office work. Options include PG&E approved break software, scheduled group breaks or individual break strategies.

**32. Packing, Unpacking, Storage, Loading, and Unloading of Materials**

- (a) Nail points, ends of wires or bands shall not be left exposed when packing or unpacking boxes, crates, barrels, or other containers.
- (b) Nails shall be removed from loose lumber, the points bent down, or the lumber shall be properly disposed of so it will not become a hazard.
- (c) Sharp or pointed articles shall be so stored as to prevent persons from coming in contact with the sharp edges and points.
- (d) Care shall be exercised when packing or unpacking glassware, porcelain, and other fragile objects that may have sharp edges.
- (e) Loads shall not be handled from the street side of a vehicle if it can be avoided.
- (f) Special regulations and instructions governing the loading and unloading of poles, pipes, etc., shall be strictly observed in every case.
- (g) PG&E personnel are not to assemble, disassemble, operate, load, or unload equipment and materials provided by contractors and suppliers unless they have properly documented training and specific direction from their supervisor to do so

**33. Reserved****34. Work Area Protection****(a) Protective Signs and Devices**

- (1) Company-approved warning signs, barricades, “caution” and barricade tapes, guards, cones, flags, etc., shall be placed to protect the public and employees from open excavations, pits, manholes, and similar substructures. Care shall be taken to provide unobstructed walkways for pedestrians around such open excavations. Artificial lighting, flashers, etc., shall be used, as needed, for additional protection.
- (2) Employees shall use information tags or other warning devices to identify a hazard that is not obvious.
- (3) Employees shall not enter barricaded areas by going over or under barricades or tape; access shall be through designated opening points.

**(b) Barricade tape shall only be used for the intended purpose/exposure, as described below. Barricade tape shall not be used as a substitute for guard railings on work platforms or around floor holes.**

- (1) Black and yellow woven barricade tape shall be used to identify and restrict access to areas of high voltage electrical exposure.
- (2) Red and white woven barricade tape shall be used to identify hazardous areas other than those involving high voltage electrical exposure.

- 
- (3) Yellow and red woven barricade tape shall be used to identify a recognized Arc Flash Boundary.
- (c) **Vehicular Traffic Exposure**
- (1) Where the job site is on or near a roadway, work area protection devices and advance warning signs shall be placed and maintained in accordance with the most recent edition of the *California Manual on Uniform Traffic Control Devices* (MUTCD) for Street and Highways and *California Joint Utility Traffic Control Manual*.
  - (2) Provision shall be made for all pedestrians, bicyclist and those with disabilities.
  - (3) Before performing flagger's duties, employees shall have flagger training.
  - (4) Where conditions warrant (i.e., on heavily traveled streets, on highways, lane obstructions, etc.), properly trained flaggers shall be used.
  - (5) Employees (on foot) exposed to vehicular traffic shall wear approved high visibility orange warning garments, such as vests, jackets, or shirts. During rainy weather, employees exposed to vehicular traffic may wear either orange or yellow rainwear.
  - (6) Warning garments shall be outfitted with approved reflective material and must be worn during the day and at night. Warning garments with approved reflective material (vests, jacket or shirt) must be worn at all times while exposed to vehicular traffic. Orange colored clothing does not exempt

employees from wearing approved warning garments with reflective material.

### 35. Transportation

- (a) All loads in automobiles, trucks or construction equipment shall be secured. This includes ladders, tools, materials and equipment. Items that cannot be stored in a vehicle trunk or bin must be placed on the floor or secured so they cannot injure the vehicle occupants. Before proceeding, driver shall make certain that loads are properly secured and that passengers are not exposed to falling or overhead hazards or hazards from shifting loads.
- (b) Employees shall not ride on fenders, running boards, side rails, or on top of vehicles.
- (c) Employees shall ride in designated passenger seats of any vehicle used for Company business and shall not ride with their legs hanging out of the rear or side of a vehicle.

**Exception:** Employee may be transported in buckets if all of the following conditions are met:

- (1) The equipment is specifically designed for this type of operation
- (2) All controls and signaling devices are tested and are in good operating condition
- (3) An effective communication system is maintained at all times between the bucket or platform operator and where applicable, the vehicle operator
- (4) The route to be traveled is surveyed immediately prior to the work trip, checking for overhead obstructions, traffic, holes in the pavement, ground or shoulder, ditches,

- slopes, etc. For areas other than paved, a survey shall be made on foot
- (5) The speed of the vehicle does not exceed 3 miles per hour
  - (6) Only one employee is in the basket
  - (7) Both the driver and/or the elevated employee have been specifically trained for this type of work (towering) in accordance with the manufacturer's recommendations.
- (d) Employees shall not get on or off vehicles in motion.
  - (e) Each employee in a vehicle shall use a seat belt that is properly fastened at all times while driving or riding in Company vehicles. **Exception:** Seat belts need not be worn by employees using motor graders not designed for seated operations or smooth steel wheel rollers where the operator stands at the extreme rear of the vehicle.
  - (f) No internal combustion engine fuel tank shall be filled while the engine is running.
  - (g) While fueling, the vehicle or equipment operator must be present while fuel is dispensed. The operator must discharge static electricity prior to fueling. The operator shall not re-enter the vehicle during fueling.
  - (h) Fuel shall only be dispensed into approved containers.
  - (i) Employees working on vehicles with bucket/digger derrick shall follow fall protection practices.
    - (1) Move the bucket to the ground using the lower controls and access bucket from the ground level.

- (2) Walkways (“catwalks”) used to access buckets and controls shall be kept clear at all times.
- (3) Keep your “eyes-on-path” when accessing buckets and controls.
- (4) Maintain 3 points of contact when on top of the vehicle, accessing buckets and controls. Always face the vehicle or equipment when you climb in or climb out.
- (5) Do not carry material and tools to the bucket from the walkways.
- (6) Booms should be fully stowed before accessing the catwalk.
- (7) No work shall be performed while on the walkways unless fall restraint is in place.

**36. Cranes, Hoists, and Derricks**

- (a) Cranes, hoists, and derricks shall be operated only by an authorized person with the training and knowledge required for the specific crane, hoist or derrick.
- (b) When mobile hoists, cranes, booms, or other similar lifting devices are used near energized equipment, employees shall remain clear of energized equipment until the equipment is in a safe position. The employee-in-charge shall check and determine that employees remain in the clear while the vehicle is being moved or the boom is being repositioned.
- (c) Employees shall not ride on loads suspended from cranes, hoists, or derricks.
- (d) Employees shall ensure that a sign is posted in the cab of outdoor portable cranes, hoists, and derricks that reads essentially as follows:

*“Unlawful to operate this equipment within 10 feet of high voltage lines of 50,000 volts or less. The clearances in the table below do not apply to authorized work by Qualified Electrical Workers on or near energized high voltage conductors or apparatus.”*

Operators not qualified to exercise the above exemption, or not under the immediate, direct supervision of a QEW, shall maintain the distances from energized high voltage lines specified in the following table:

### Minimum Clearance Distances

*(For Operators of Cranes, Hoists, and Derricks who are not Qualified Electrical Workers or Under the Direct Supervision of a Qualified Electrical Worker)*

<b>Voltage (nominal, kV, alternating current)</b>	<b>Work Zone Clearance Distance (feet)</b>
Up to 50 kV	10
Over 50 to 175 kV	15
Over 175 to 350 kV	20
Over 350 to 550 kV	27
Over 550 to 1,000 kV	45

**Note:** If the voltage of the power line involved is not known, consult an appropriate electric department representative.

- (e) Operators shall not move loads over workers or others unless authorized by the employee-in-charge. Operators shall not leave cranes, hoists,



or derricks unattended while load is suspended, unless suspended over a barricaded area, blocked or otherwise supported from below during repair, or in an emergency.

- (f) No crane, hoist, or derrick shall be loaded in excess of its rated capacity.
- (g) Crane, hoist, or derrick operators shall take signals only from the person designated by the employee-in-charge.
- (h) Employees shall use the uniform hand signals to signal overhead traveling cranes and the signals in the Data Section to signal derrick and crane operators. The appropriate chart depicting and explaining the system of signals to be used shall be conspicuously posted in the vicinity of hoisting operations (cage or cab if so equipped).

**37. Meter Reading and Collection**

- (a) A proper type ladder or other safe support shall be used when it is necessary to climb to an elevated position.
- (b) Employees shall close or properly guard the opening upon entering a cellar, basement, stairway, shaft, or similar enclosure through an opening that is equipped with a closing device.
- (c) Regularly used walkways and gates shall be used.
- (d) Employees shall note unfriendly animals or hazardous conditions in the electronic meter reading (EMR) device. Where necessary, arrangements shall be made with the customer to remove or confine the animal or abate the hazard. Hazardous conditions shall be reported to the appropriate supervisor.

- (e) Employees shall never enter a yard when multiple dogs are present. Employees shall alert the customer by knocking on door, or honking vehicle horn, in an effort to have all animals secured. Employees shall evaluate the situation before proceeding to determine safe access to obtain a meter reading, or the meter shall be missed.
- (f) Employees shall carry the Dog Wand as personal protective equipment to every meter location. **Exception:** carrying a dog wand is not required for NON-RESIDENTIAL areas such as business parks, or commercial industrial areas.
- (g) Meter readers must wear appropriate type footwear that provides high ankle support with an aggressive sole to prevent slips and falls while performing their assigned route.

**38. Radio Operation**

Transmitting radios shall be turned off, or otherwise rendered incapable of transmitting when vehicle is being fueled, or within 50 feet of fuel pumps, or within 300 feet of a blasting zone.

**39. Rigging**

- (a) Only employees trained and qualified to rig shall do so.
- (b) Employees shall:
  - (1) Use Company-approved rigging
  - (2) Inspect rigging components prior to and during use to ensure they are in good working order
  - (3) Not exceed the working load limits of any component.
- (c) Employees shall position themselves such that they are not at risk of an injury in the event that

one of the rigging components fails or control is lost.

**First Aid  
Contents**

<b>Rule</b>	
<b>201</b>	<b>Scope</b>
<b>202</b>	<b>General</b>
<b>203</b>	<b>Training</b>
<b>204</b>	<b>First Aid Kits</b>
<b>205</b>	<b>Transportation</b>

**First Aid  
Contents****201. Scope**

These rules shall apply to Company employees.

**202. General**

- (a) Each work site, facility or field location shall have one site specific First Aid/Emergency Plan. Employees shall know the requirements of the First Aid/Emergency Plan for their work site, including the provisions for emergency transportation and communications in work areas where public emergency transportation is not available. Employees shall review the plan annually or any time that the First Aid/Emergency Response provisions change.
- (b) Only employees trained and certified to provide First Aid/CPR shall do so.
- (c) Emergency medical services shall be summoned in accordance with CSP Rule P-14(c) (3) or (d)(2) and based upon severity of the injury and the ability of the employees present to provide First Aid/CPR.
- (d) Trained employees may provide First Aid/CPR to third parties at their own discretion and as deemed necessary or in the event of a life-threatening emergency; however, this is not a requirement of employment.
- (e) Every injured employee shall receive First Aid/CPR once it is safe to do so. Employees are required to either immediately secure medical assistance or provide First Aid/CPR to injured employees until emergency medical personnel arrive.

### **First Aid Contents**

- (f) Universal precautions, as defined in the Company's Bloodborne Pathogen Exposure Control Plan, shall be taken by employees providing first aid, performing CPR, or if there is a potential for contact with blood or other potentially infectious materials.
- (g) Injuries requiring First Aid/CPR treatment shall be communicated as soon as possible to the injured employee's supervisor. Refer to CSP Rule P-14 for notification requirements.
- (h) Employees assigned responsibility for maintenance of first aid kits and employees that are provided first aid kits for use in assigned or designated vehicles shall inspect first aid kits at the time of assignment, and monthly thereafter. These inspections shall be documented and items that are used, missing or expired shall be replaced.

### **203. Training**

- (a) Employees who perform the following types of work shall attend an initial Certified First Aid/CPR training and periodically thereafter as required by the training provider:
  - (1) Construction or maintenance crew work
  - (2) Support work in a telecommunications manhole
  - (3) Work in an Other Confined Space using respiratory protection
  - (4) Work in a Permit Required Confined Space or Confined Spaces in Construction or as a member of the rescue team
  - (5) Tree maintenance or removal work

### **First Aid Contents**

- (6) Diving as part of a dive team
- (7) Work in tunnels
- (8) First Aid Attendant
- (b) Employees who attend Certified First Aid/CPR training shall attend the Company's Bloodborne Pathogen training annually.

#### **204. First Aid Kits**

- (a) Responsible individual(s) are to:
  - a. Purchase Company physician-approved first aid kit supplies
  - b. Determine where to place first aid kits
  - c. Inspect and maintain first aid kits.
- (b) Three different Company physician-approved configurations of the first aid kit are available: 10-unit, 16-unit, and 24-unit kits. Kits shall only contain required contents.
- (c) Kits shall be purchased using established Company purchasing procedures. Purchase of kits and supplies are disallowed by commercial card and personal expenses.

#### **205. Transportation**

- (a) A person with serious injuries shall only be moved if they are in danger of being further injured, such as from fire, collapse of a building, or automobile traffic. Improper handling of an injured person may cause additional injury or the complication of an existing injury.
- (b) If emergency medical services as described in the First Aid Plan are delayed or unavailable, transport the victim by the best method available,

**First Aid  
Contents**

taking care not to cause additional injury or complicate an existing one.

- (c) Seriously injured persons shall be moved on a stretcher or in a lying-down position whenever possible.
- (d) Transport persons with open wounds or where there is potential for exposure to body fluids in accordance with the Company's Bloodborne Pathogen Exposure Control Plan, as described in SH&C Procedure 233.



---

**MOTOR VEHICLE OPERATION  
Contents**

<b>Rule</b>	
<b>301</b>	<b>Scope</b>
<b>302</b>	<b>Knowledge and Compliance with Laws</b>
<b>303</b>	<b>License and Permit Requirements</b>
<b>304</b>	<b>Defective Equipment</b>
<b>305</b>	<b>Brake Tests</b>
<b>306</b>	<b>Waste or Burning Materials</b>
<b>307</b>	<b>Children</b>
<b>308</b>	<b>Right-of-Way</b>
<b>309</b>	<b>Movement of Vehicles</b>
<b>310</b>	<b>Vehicle Booms, Ladders, and Lifts</b>
<b>311</b>	<b>Turning, Stopping, and Required Signals</b>
<b>312</b>	<b>U-Turns</b>
<b>313</b>	<b>Parking and Securing Vehicles</b> <b>(Revised 5/2018)</b>
<b>314</b>	<b>Stopping for School Buses</b>
<b>315</b>	<b>Crossing or Stopping at Grade Crossing</b>
<b>316</b>	<b>Overtaking and Passing</b>
<b>317</b>	<b>Speed Laws</b>
<b>318</b>	<b>Coasting Prohibited</b>
<b>319</b>	<b>Towing</b>
<b>320</b>	<b>Trucks and Heavy Equipment</b>
<b>321</b>	<b>Following Too Closely</b>
<b>322</b>	<b>Freeway Driving</b>
<b>323</b>	<b>Seat Belts</b>
<b>324</b>	<b>Operation of Off-Road Utility Vehicles</b> <b>(OUVs)</b>
<b>325</b>	<b>Operation of Soft Track Vehicles</b>
<b>326</b>	<b>Fatigue Management for Commercial</b> <b>Licensed Drivers</b>
<b>327</b>	<b>Motorcycle Usage</b>

---

## MOTOR VEHICLE OPERATION

### Contents

#### 301. Scope

Employees shall follow the rules in this section whenever driving a Company vehicle, privately owned vehicle under contract to the Company, or whenever the employees are being compensated for the use of a vehicle on a mileage or salary basis by the Company.

#### 302. Knowledge and Compliance with Laws

Drivers shall be familiar with and obey the information contained in the current DMV Motor Vehicle Handbook, State Vehicle Codes, California Fire Codes (e.g., vehicle clearance [exhaust system clearance], fire index, spark arrestor, tool/equipment requirements, etc.), local traffic rules and ordinances, traffic control signs, posted speed limits, parking restrictions, and seatbelt use. Company rules governing vehicle operation established in SAFE-1002S Motor Vehicle Standard and TRAN-1002S Assignment and Personal Use of Company Vehicles Standard which prohibits smoking (e.g., all tobacco use) and cell phone use or using a wireless communication device while driving a vehicle as described in CSP Rule 301.

#### 303. License and Permit Requirements

- (a) Employees who drive a vehicle that meets the description in CSP Rule 301 shall have a valid Driver's License in their possession at all times.
- (b) Employees required to operate a vehicle under a Class A or B commercial license shall have, in their immediate possession, a valid commercial

**MOTOR VEHICLE OPERATION****Contents**

driver's license of the appropriate class, and a current medical certificate.

- (c) All commercially licensed drivers, before driving a commercial regulated vehicle, shall be enrolled in the State Mandated DMV Pull Notice Program, and have a driver qualification record on file.

**304. Defective Equipment**

When the safe operation of a piece of equipment is in doubt, employees should contact Transportation Services prior to moving any unit. The Transportation Services supervisor or designate will determine whether or not the unit can be driven safely under normal conditions, can be driven safely at a reduced speed, or can be driven safely in such a manner as to enable the movement to the nearest garage or repair facility.

**305. Brake Tests**

- (a) Employees shall make a test application of brakes at the start of each day's operation.
- (b) When employees operate a brake-equipped trailed vehicle, this test shall be made on the towing vehicle each time the trailed vehicle is coupled or uncoupled and shall include visual inspection of brake hoses and couplings, and an actual test of all possible braking combinations.

**306. Waste or Burning Materials**

Drivers or passengers shall not throw garbage, trash, waste paper, burning material, or other objects from vehicles.

---

**MOTOR VEHICLE OPERATION**  
**Contents**

**307. Children**

Employees shall drive with extra care when passing school grounds, playgrounds, or in the vicinity of children.

**308. Right-of-Way**

Employees shall drive courteously at all times and should yield the right-of-way to other vehicles or pedestrians, if there is any question as to which vehicle or pedestrian has the right-of-way.

**309. Movement of Vehicles**

- (a) Before starting to move a vehicle either forward or backward, drivers shall determine that no person or object is in the path of the vehicle. Alert others of your intention to move the vehicle either forward or backward by using the horn as an additional means of communication.
- (b) Before backing a vehicle, drivers shall request a passenger or other nearby Company employees (if available) to observe during the backing of the vehicle. Vehicles equipped with back-up cameras shall utilize the camera as a tool in addition to rear and/or side mirrors as well as observers (when available). Additionally, when looking over your shoulder (and utilizing mirrors, cameras, etc.), does not clearly depict potential backing hazards, drivers shall park and get out to visually verify the area is free of hazards before proceeding to back. Cameras shall not be used as the sole means of vision behind a vehicle while backing.

**MOTOR VEHICLE OPERATION****Contents**

- (c) Drivers shall ensure a vehicle's headlights are on at all times during the vehicle's operation. (Note: parking lights and daytime run lights cannot be used in lieu of headlights.)

**310. Vehicle Booms, Ladders, and Lifts**

- (a) Employees who drive vehicles equipped with booms used for setting or removing poles, truck mounted ladders, hole diggers, or similar equipment, shall not drive with such equipment unsecured or in an elevated or partially elevated position.
- (b) Proper precautions shall be taken at all times to prevent contact with overhead lines, trees or structures.

**311. Turning, Stopping, and Required Signals**

Drivers shall not turn a vehicle from a direct course or move right or left unless (and until) such movement can be made safely, and then only after giving an appropriate signal using the turn signal. In the event that the turn signals become inoperable, hand and arm signals shall be used.

**312. U-Turns**

Drivers shall plan routes to avoid U-turns, if possible. When such turns cannot be avoided, appropriate signaling requirements shall be observed. Drivers shall comply with state and local requirements governing U-turns.

**313. Parking and Securing Vehicles**

- (a) Drivers shall comply with state and local parking regulations except when exemption from these regulations has been granted for work involving

**MOTOR VEHICLE OPERATION****Contents**

construction, operations, removal, or repair of utility facilities. Vehicles parked under these special conditions shall be protected by warning devices specified in the regulations.

- (b) For a vehicle to be “parked and secured” the vehicle must be in gear or the transmission placed in the “park” position, the parking brake set and the ignition turned to the off position. Simply stopping a vehicle, either at the side of the roadway or in a parking lot and using the brake only does not secure or “park” a vehicle. It is the responsibility of the driver to make sure the vehicle is “parked” or “secured” prior to performing any other duties or activities. Prior to leaving the controls of a vehicle or mobile equipment, drivers shall turn one wheel against the curb when parked on a hill or incline, set the parking brake, place the transmission in the “park” position, and shut off the engine ignition (unless the engine is needed to power auxiliary equipment or to keep the battery charged during extended use of the vehicle's lights).

Power Generation Exception: When outside temperatures are at or below freezing or if the windshield is visibly frosted over, a driver may exit his/her vehicle with the engine left running/idling to warm up, defrost the windshield, etc., provided the following is done prior to exiting the vehicle:

- One wheel has been effectively chocked;

**MOTOR VEHICLE OPERATION****Contents**

- The vehicle is on substantially level ground;
- The vehicle's transmission is placed in the "park" position;
- The emergency brake is securely engaged.

Whenever possible, the driver must remain in line-of-site with the unattended vehicle and at no time should a vehicle be left unattended for a period greater than 10 minutes.

Vehicles left idling to defrost, warm-up, etc., shall have a driver at the controls at all times until the ignition is shut off. (Diesel vehicles 10,001 pounds (lbs.) gross vehicle weight rating (GVWR) and greater must comply with the Diesel Idling Rules which can be found on the Environmental Services Website.) See [ENV-1003S - Vehicle Idling Standard](#).

- (c) Drivers of Company vehicles (10,001 lbs. GVWR and greater) shall always use wheel chock blocks in addition to setting the appropriate parking system to secure the vehicle. Operators of equipment (e.g., trailers, tractors, backhoes, loaders, etc.) shall (as appropriate for the equipment) ensure front buckets and/or auxiliary buckets and outriggers are down to secure the equipment or use wheel chock blocks.
- (d) Wheel chocks are not a CSP requirement for vehicles (below 10,001 GVWR), which include passenger vehicles, sport utility vehicles and pick-up trucks (3/4 ton or less with a regular truck

**MOTOR VEHICLE OPERATION****Contents**

bed). Several PG&E department operational manuals indicate organizations can and do require chocks to secure vehicles. It is acceptable for organizations to go above and beyond what is detailed in the CSP. The requirement is the driver/operator effectively park/secure the vehicle/equipment before leaving the controls. Once the vehicle is parked/secured the controls can be left and appropriate chocks then put in place. Consult with local supervision or local PG&E department operations manual(s) to determine what is or is not required for your specific organization.

- (e) Drivers shall park vehicles in a safe, secure location to the extent possible under existing conditions. Whenever possible, employees shall pull through or back into parking stalls if safe to do so. Employees who park vehicles in areas other than a roadway shall park the vehicle without damaging property. The area around the vehicle shall be inspected immediately prior to moving the vehicle (Circle of Safety) to ensure that chocks or other devices and equipment have been put back on the vehicle and that no hazards exist that will impact the employees, the vehicle, third-party property, or other vehicles and drivers.

**314. Stopping for School Buses**

Upon meeting or overtaking a school bus displaying flashing red lights and/or a stop sign, employees shall stop and remain stopped in either direction until the red lights cease to



**MOTOR VEHICLE OPERATION****Contents**

operate or the bus driver disengages/lowers the stop sign.

**315. Crossing or Stopping at Railroad Grade Crossings**

Drivers shall comply with Vehicle Code requirements covering crossing and/or stopping at railroad crossings.

These requirements include but are not limited to:

- a) Look in both directions and listen for trains. Many crossings have multiple tracks so be ready to stop before crossing, if necessary. Cross railroad tracks only at designated crossings and only when it is safe to do so. Proceed directly across the tracks without stopping or shifting the vehicle while on the tracks.
- b) Expect a train on any track at any time traveling in either direction. If you need to stop after crossing the tracks make sure your vehicle clears (minimum of 6 feet from closest track) the tracks before you stop.
- c) Watch for vehicles that must stop before crossing train tracks. These vehicles include buses, school buses, cargo tankers and trucks transporting hazardous loads.
- d) Remember that flashing red lights mean STOP! Stop at least 15 feet from the nearest track when the crossing devices are active or a person warns you a train is coming. Stop if you see a train coming or you hear the whistle, horn, or bell of an approaching train.

**MOTOR VEHICLE OPERATION****Contents**

- e) Do not go around or under lowered crossing gates, even if you do not see a train. Wait for the gates to rise or find an alternate route. If the gates are not working correctly, call the railroad emergency number posted near the crossing or notify the local police or California Highway Patrol.

**316. Overtaking and Passing**

- (a) Drivers shall overtake and pass vehicles only when the roadway is clearly visible and free of traffic for sufficient distance ahead as to safely permit such a maneuver, and passing is not prohibited by highway signs or markings.
- (b) Drivers shall comply with Vehicle Code requirements covering the overtaking and passing of vehicles upon grades.

**317. Speed Laws**

- (a) Drivers will travel at a speed that is safe for all conditions including traffic, surface and width of roadway, weather conditions, visibility, etc.
- (b) Drivers shall comply with all speed limit signs including those specifically posted for certain situations such as blind crossings, business and residential districts, and other special zones and for various types of vehicles, trailers or combinations of towed-vehicles.

**318. Coasting Prohibited**

Drivers shall not coast with transmission control in neutral position or the clutch disengaged.

**319. Towing**

- (a) Drivers shall comply with applicable Vehicle Code requirements covering towing of vehicles.

**MOTOR VEHICLE OPERATION****Contents**

(D.O.T. Federal Motor Carrier Safety Regulations Section 393.70(B))

- (b) Employees shall use safety chains or cables as a Safety device. The Safety device must be connected to the towed and towing vehicles, trailers, equipment, etc., and to the tow-bar in a manner which prevents the tow-bar from dropping to the ground in the event it fails or becomes disconnected.
- (c) It is the responsibility of the driver to ensure all towed vehicles, trailers, equipment, etc., are properly secured and connected prior to any movement.

**320. Trucks and Heavy Equipment**

- (a) Drivers shall comply with Vehicle Code regulations governing the driving of all trucks and heavy equipment, and the maximum weights, widths, heights and overhang of loads. Binders shall be used, and overhanging loads shall be protected by flags or lights, as required by Cal-Trans or local jurisdiction permits.
- (b) Employees driving larger trucks (e.g., 10,001 GVWR or greater), all trucks towing a trailer or heavy equipment shall, so far as possible, avoid restricting the normal flow of traffic by permitting traffic to overtake and pass through, using turn-outs at railroad crossings, or pulling off and stopping on road shoulders. When reentering traffic, employees are fully responsible for entering safely.
- (c) Employees shall maintain three points of contact when entering or exiting vehicles or equipment.

**MOTOR VEHICLE OPERATION****Contents**

Employees shall face the vehicle or equipment when climbing in or backing down.

**321. Following Too Closely**

Employees shall maintain at least a 4-second distance between their vehicle and vehicles in front of them. This requires drivers to continually adjust their space cushion. A 4-second distance is measured by counting the seconds between when the vehicle in front passes a stationary object near the side of the road (such as a sign or building) to when the driver's vehicle passes the same object. At least 4 seconds shall be counted. Weather or other conditions (e.g., heavy traffic, presence of emergency vehicles) shall dictate a larger following distance to minimize the possibility of an incident.

**322. Freeway Driving**

- (a) Drivers entering a freeway on an access ramp shall enter the freeway at or near the speed of traffic. Drivers shall not stop before merging with freeway traffic unless absolutely necessary. Freeway traffic has the right of way.
- (b) Where possible an off-ramp should be entered without materially reducing speed until the vehicle is completely clear of freeway lanes
- (c) While on a freeway, drivers shall:
  - (1) Keep up with the flow of traffic in the lane in which they are traveling (within posted speed limitations).
  - (2) Maintain adequate stopping distance. (A minimum of a 4-second distance between the vehicles, as described in CSP Rule 321.)

**MOTOR VEHICLE OPERATION****Contents**

- (3) Change lanes only where there is adequate space and after proper signaling, using mirrors and turning your head, watching out for blind spots.
- (4) Watch vehicles and scan ahead carefully for possible speed changes.
- (d) The right lane of a freeway shall normally be used for:
  - (1) On and off ramp driving
  - (2) Driving slower than traffic in other lanes
  - (3) A motor truck or truck tractor having three axles or more, or a motor truck or tractor towing another vehicle.

**323. Seat Belts**

- (a) Drivers and passengers shall wear seat belts as required in the California Vehicle Code and CSP Rule 35(e).
- (b) Seatbelts are required on equipment with Rollover Protective Structures (ROPS). This also applies to OUV's and Low Speed Vehicles referenced in CSP Rule 324.

**324. Operation of Off-Road Utility Vehicles (OUVs)**  
***For Detailed Safety Information refer to Work Procedure: TD-2412P-01 OUV, UTV and Cart Operation***

Vehicles that can exceed 25 miles per hour (mph) are referred to as OUVs. Vehicles whose maximum speed is 25 mph are referred to as Low Speed Vehicles.

- (a) **General Operating Requirements**
  - (1) Company-approved OUVs, such as Polaris Models Razor and Ranger, are capable of

**MOTOR VEHICLE OPERATION****Contents**

transporting employees and equipment through snow, mud, and narrow path ways, within company facility boundaries on unpaved surfaces, and off roads in areas normally inaccessible to standard 4-wheel drive vehicles.

- a. Polaris Razors are designed to hold up to 2 persons.
  - b. Polaris Ranger XP 4x4, Polaris Ranger Crew XP 4x4 and Polaris Ranger 6X6 vehicles are designed to hold up to 3 persons, 6 persons and 3 persons, respectively.
  - c. When transporting material in the cargo area or towing a trailer, refer to the operator's manual for rated capacities.
- (2) Low Speed Vehicles (i.e., certain Utility Task Vehicles (UTVs) or electric carts) are for transporting employees and light-weight materials within company facilities either paved or off-road. Company-approved low-speed vehicles for purchase include: Taylor Dunn, John Deere Gator, Ford, E-Z-GO, Ultra Trak, Motrec, Yamaha and other units specified by Transportation Services which are designed for low speed travel (under 25 mph), flat or level ground, and for transporting employees.
- (3) Transportation Services can provide the manufacturer's specifications for Company-approved equipment for purchase.
- (4) Other types of OUVs and UTVs are available

---

**MOTOR VEHICLE OPERATION****Contents**

for rental if they are approved by  
Transportation Services.

**(b) Training**

The operator-in-training must have the following skills:

- (1) Be familiar with the manufacturer's operation and maintenance manual and recommended operating procedures.
- (2) Complete PG&E Academy training (EQIP-0066) specific to OUVs or Low Speed Vehicles; this includes reviewing a training outline, safety video and hands-on operation with a qualified instructor.

**MOTOR VEHICLE OPERATION****Contents**

**Note:** EQIP-0666 training qualifies operators who may rent one of several brands of OUV / low-speed vehicles.

- (3) Practice in safe areas that are free from obstacles and have a consistent surface of sand, dirt, snow, etc.
- (c) **Personal Protective Equipment (PPE):**  
Wear required clothing and PPE for the specific work and location.
- (1) Minimum required PPE shall include a Company-approved helmet for OUV (high speed vehicle) use and eye protection (goggles or attached eye visor to the helmet).
  - (2) Minimum PPE requirements for low-speed vehicles include a hard hat and eye protection (e.g. safety glasses).
  - (3) Other PPE items stated in the operator's manual of each specific vehicle are also required.
  - (4) Additional PPE must be worn if required by the operator's line of business or facility.
  - (5) Use approved ear protection as defined in SAFE-2003S Noise Control Standard.
- (d) **Maintenance**  
Follow the manufacturer's recommendations for lubricating and servicing of vehicles.  
Transportation Services performs or authorizes service and/or repair of purchased vehicles.  
Rental vehicles are serviced and managed per the rental contract agreement. Complete the



**MOTOR VEHICLE OPERATION****Contents**

following maintenance checks before using the vehicle:

- (1) Ensure that the brakes (front and rear) are properly adjusted.
  - (2) Check the fuel tank for leaks.
  - (3) Check the engine oil level (add when needed) and check water level (add when needed).
  - (4) Ensure the air filter is clean.
  - (5) Ensure all other manufacturer-suggested check points are within specification before each use.
- (f) **Pre-Trip Inspection**
- (1) Complete a pre-trip inspection before each use (for Company-owned or rental vehicles).
    - a. Always check the tires (condition and pressure), lights, horn, and other safety-related items per the operator's manual specific to each vehicle.
    - b. Check the brakes, throttle, fluids and all hand controls for proper operation.
    - c. Check the fuel tank to make sure it contains more than enough fuel for the ride, and
    - d. Ensure doors are on or cab net kit is installed.
  - (2) A first aid/emergency response plan that documents routes, communication method and emergency response specifics must be in place if traveling outside a fenced-in Company facility.
  - (3) Ensure that the vehicle is equipped with:

**MOTOR VEHICLE OPERATION****Contents**

- a. Operator's manual
  - b. A shovel and an ax that meet local and California Department of Forestry and Fire Protection requirements (when applicable).
  - c. When working in remote locations where communication devices do not function, a personal local beacon (PLB) may be helpful but is not required.
- (4) Ensure that no unauthorized attachments to haul material have been added to the vehicle and never transport material on a vehicle, except in a designated cargo box where the material is properly secured.
  - (5) Do not operate vehicles with malfunctioning parts.
  - (6) Know the round-trip capability of the vehicle and do not attempt a long trip that may be beyond its capacity.
  - (7) Except in emergency situations, secure permission before traveling over private property outside normal access or right-of-ways.

**325. Operation of Soft Track Vehicles**

Employees who operate vehicles with a soft track (i.e., Snow Cats, Snowmobiles, etc.), that are company owned or rented, shall operate vehicles on adequate snow cover so as to have little effect on soils or on soil-dependent biotic communities. Whenever possible, soft track vehicles shall avoid running over trees and shrubs and shall not

---

## MOTOR VEHICLE OPERATION

### Contents

intentionally disturb animals or other outdoor users.

(a) **Training**

The operator-in-training must have the following skills:

- (1) Be familiar with the manufacturer's operation and maintenance manual and recommended safe operating procedures.
- (2) Complete PG&E Academy training (EQIP-0046) specific to Snow Cats or Snowmobiles. Training includes: reviewing a training outline, safety video, maintenance and repair essentials, emergency response and/or survival basics, and hands-on training on the specific model/brand of vehicle intended for use with a qualified instructor.
- (3) Documented hands-on practice, in areas free from obstacles, under the observation of a qualified instructor.

(b) **Personal Protective Equipment (PPE)**

- (1) Wear layers of clothing so that you can add or remove layers to match changing conditions. This includes a windproof outer layer, warm gloves or mitts, thermal under layers and weather/water proof boots. Snow Cat operators should bring these items inside the cab.
- (2) Full-face helmet with visor for clear vision and wind protection and glasses or goggles (with tint during daylight hours) shall be worn when operating or traveling on a Snowmobile. No tint glasses or goggles

**MOTOR VEHICLE OPERATION****Contents**

shall be worn during any night operation or travel.

- (3) Glasses or goggles with tint shall be worn when operating or traveling in a Snow Cat during daylight hours.
  - (4) Snow Cats and Snowmobiles shall be equipped with a Company-approved First Aid/Survival Kit specific to winter conditions.
- (c) Pre-Trip Inspection
- (1) Make a pre-trip inspection before each use (Company owned or rental). Always check the track slack, lights, horn, and other safety related items (such as extra tools for repair) per the Operators Manual specific to each vehicle.
  - (2) Check the brakes, throttle, fluids and all hand controls for proper operation.
  - (3) Never transport material on a vehicle except in a designated cargo box where the material is properly secured.
  - (4) A First Aid/Emergency Response Plan that documents planned route(s), communication method(s) and emergency response specifics, must be in place and communicated to all passengers if traveling outside of a fenced-in Company facility.
  - (5) When traveling to remote locations where communication devices do not function, refer to the safety tailboard "[Working Alone in Remote Locations – Personal Locator Beacon.](#)"

**MOTOR VEHICLE OPERATION****Contents**

- (6) Know the round-trip capability of the vehicle and do not attempt a long trip that may be beyond its capacity. Carry extra gasoline or diesel in safety cans when necessary.
- (7) Except in emergency situations, secure permission before traveling over private property outside normal access or right-of-ways.

**326. Fatigue Management for Commercial Licensed Drivers**

Supervisors and all commercial licensed drivers shall follow Utility Procedure TRAN-2001P-01.

---

**MOTOR VEHICLE OPERATION**  
**Contents**

**327. Motorcycle Usage**

- (a) Motorcycle usage will be prohibited during normal working hours while on Company business. For purposes of this section, "on Company business" is anytime an employee is being paid for mileage to drive their personal vehicle.

**EXCEPTION:** Diablo Canyon Power Plant (DCPP) employees required to respond for ERO duties are permitted to drive their personal motorcycle when traveling to locations on Company business. Employees are highly encouraged to secure alternate means of transportation whenever possible.

- (b) If an employee were to commute on a motorcycle and needed to drive to another location for work purposes, the supervisor must do one of the following:
- (1) Provide a company vehicle
  - (2) Provide a rental vehicle

## **APPENDIX J**

### **Topock Remedy Work Task List**

**TOPOCK REMEDY WORK TASK LIST**

**MW-20 Bench Carbon Amendment Building**

1	<b>Foundation</b>
	Earthwork for MW-20 Bench Carbon Amendment building foundation construction.
	Install all process mechanical piping below the foundation and floor slab including stub-ups into building and stub-outs for connection to Remedy piping; complete connections to underground Remedy piping installed under other tasks.
	Install all electrical and controls conduit below the foundation and floor slab including stub-ups into building and stub-outs for connection to Remedy piping; complete connections to underground Remedy piping installed under other tasks.
	Install concrete for foundation, concrete entrance pads, concrete apron pads, column pedestal and curbs with associated anchor bolts and plates.
	Compaction testing to demonstrate conformance with the requirements for earthwork associated with this task.
2	<b>Building</b>
	Install pre-engineered metal building with all interior metal panels and insulation.
	Construct 8" CMU walls to separate Carbon Mixing Room, Well Maintenance Room, and Electrical and Control.
	Construct all equipment pads within the building.
	Furnish and install all personnel and overhead doors.
	Furnish and install sump pit grating.
Apply CRC 2 chemical resistant coating to the concrete slab top surface and concrete curb inside face.	
3	<b>HVAC</b>
	Install exhaust fans at carbon mixing room and well maintenance rooms. Install ductless air conditioning unit at electrical and control room with associated heat pump on concrete pad and condensate drain at building exterior.
4	<b>Process Mechanical</b>
Install all Remedy process piping, valves, pumps, tanks, supports, and equipment within and adjacent to the Carbon Amendment building.	
5	<b>Electrical</b>
	Install XFMR-LP-3 (45 KVA 120/240 transformer), LP-3 (120V panelboard), lighting, and receptacles; and provide lightning protection. PNL-3M, XFMR-03, and 480V distribution panels (PNL-3 and PNL-A) installed by OTHERS.
	Install all general building electrical, including lighting, receptacles, HVAC, grounding, LP-3, and XFMR-LP-3. Grounding of electrical components installed by OTHERS within the Electrical and Control Room (e.g. PNL-3M, XFMR-03) by OTHERS
	Complete building electrical and coordinate with CONSTRUCTION MANAGER for the energizing of the building. After building is energized, make final connections to panelboard PNL-3, installed by OTHERS, to power up XFMR-LP-3 and panelboard LP-3.
	Install all sleeves required for conduit penetrations through concrete and masonry for use by OTHERS.
	Install materials and equipment acceptable to AHJ (Authority Having Jurisdiction) for Class I, Division 2, and Group D due to the potential for accumulation of hazardous concentrations of combustible gases, and for exposure to corrosive environment per specification section 26 05 02 Basic Electrical Requirements, 1.08 Environmental Conditions.
Install lightning protection system	
<b>MW-20 Bench Carbon Substrate Storage Tank</b>	
1	<b>Foundation</b>
	Earthwork for MW-20 Bench Carbon Substrate Storage Tank foundation construction.
	Install all process mechanical piping below the foundation including stub-ups and stub-outs for connection to Remedy piping; complete connections to underground Remedy piping installed under other tasks.
	Compaction testing
	Install concrete for foundation with associated reinforcing steel and tank support anchorage
	Apply CRC 2 chemical resistant coating to the concrete slab top surface.
2	<b>Storage Tank &amp; Access Walkway/Platform</b>



<b>TOPOCK REMEDY WORK TASK LIST</b>	
	Install all related process mechanical piping at the storage tank and complete connections to underground process piping
	Install storage tank, platform and stairs
<b>MW-20 Bench Site Civil Improvements</b>	
<b>1</b>	<b>Clearing and Grading</b>
	Land clearing and grading.
<b>2</b>	<b>Truck Unloading Containment Pad</b>
	Earthwork for Truck Unloading Containment Pad construction.
	Furnish and install containment pad slab-on-grade, cast-in-place curb walls, and concrete bumps.
	Install trench grating.
	Apply CRC 2 chemical resistant coating to the concrete slab top surface and containment curb inside face surface.
<b>3</b>	<b>Sidewalks</b>
	Complete construction of sidewalks
<b>4</b>	<b>Fencing and Gates</b>
	Install perimeter fencing per PG&E standards with 3-strand barbed wire, personnel gates and slide gates with high security chain and locks
<b>5</b>	<b>Security and Electrical</b>
	Install empty conduit with pull string for security camera system around MW-20 Bench site including earthwork.
	Install empty conduit with pull string for all instrumentation and controls at Carbon Substrate Storage Tank
	Install all conduit and wiring to the east side of the Truck Unloading Containment Pad for local disconnect of sump pump including conduit beneath hardscape and concrete penetrations as-needed.
	Install conduit, wiring, and associated electrical hardware and supports for installation of electrical receptacles at exterior of Carbon Amendment Building and Truck Unloading Containment Pad.
<b>6</b>	<b>Yard Piping</b>
	Install all Remedy yard piping into the MW-20 Bench site per the Bid Documents including excavation and backfill. Remedy piping, including all conduits and concrete encasement, will connect to Remedy system piping installed by OTHERS at a location within 10 feet of the edge of the MW-20 Bench yard.
	Install fire hydrant.
<b>Electrical - Topock Compressor Station (TCS)</b>	
<b>1</b>	<b>TCS Connection</b>
	Install all electrical wiring between the pull box located outside of TCS Auxiliary Building and the Remedy 480V Switchgear. Installation of underground conduits pull boxes, handholes, and associated penetrations by OTHERS.
	Install all conduit and supports necessary to complete the connection from the pull box outside the TCS Auxiliary Building to the TCS Switchgear including excavation, exposed conduit transition, and backfill. Electrical wiring between pull box outside TCS Auxiliary Building and TCS Switchgear and connection to energize by OTHERS.
<b>2</b>	<b>480V Switchgear/Node 99</b>
	Install XFMR-99 including construction of the 12kV Transformer concrete pad, removable guard posts, and grounding system.
	Install Remedy 480V Switchgear and Medium Voltage Remote Power Main Breaker. Installation of Remedy 480V Switchgear pad, including conduit stub ups, by OTHERS. CONTRACTOR shall coordinate with the CONSTRUCTION MANAGER to ensure electrical conduit stub-ups to be installed by OTHERS are properly located.
	Install all conduit, electrical wiring, and supports to interconnect the Remedy 480V switchgear, XFMR-99, and the Medium Voltage Remote Power Main Breaker including excavation, exposed conduit transitions, and backfill between the 12kV Transformer pad and the Remedy 480V Switchgear pad. Underground electrical conduit for interconnect of XFMR-99 with electrical infrastructure installed on the Remedy 480V Switchgear pad will be stubbed out 5 feet from the Remedy 480V Switchgear pad by OTHERS where the CONTRACTOR is to complete the connection.

**TOPOCK REMEDY WORK TASK LIST**

3	<b>TCS Yard Electrical</b>
	Install all electrical wiring between the Remedy 480V Switchgear, PBX-P1A at the Remedy Produced Water Conditioning Plant, and the Generator Connection Panel. Installation of underground electrical conduit, pull boxes, associated penetrations, and Remedy 480V Switchgear conduit stub-ups installed by OTHERS.
	Install all conduit and supports necessary to complete conduit connection from the conduit stub-ups installed by OTHERS at the Remedy 480V Switchgear pad to the Remedy 480V Switchgear.
	Install Generator Connection Panel including construction of the concrete pad and associated exposed conduit transition. Underground electrical conduit will be stubbed out 5 feet from the generator connection pad by OTHERS where the CONTRACTOR is to complete the connection.
	Install all electrical wiring between PBX-P1A at the Remedy Produced Water Conditioning Plant and PBX-D1G at the Remedy Freshwater Storage Tank. CONTRACTOR shall leave 10 feet of free-spooled wiring within PBX-D1G. Installation of underground electrical conduit, pull boxes, handholes, and associated penetrations by OTHERS.
4	<b>Remedy Produced Water Conditioning Plant</b>
	Install the motor control center (MCC) and XFMR-LP at the Remedy Produced Water Conditioning Plant. CONTRACTOR shall coordinate with the CONSTRUCTION MANAGER to ensure electrical conduits to be installed by OTHERS are properly located for equipment installation.
	Install all electrical wiring between the MCC at the Remedy Produced Water Conditioning Plant Electrical Room and PBX-P1A for MCC energization and distribution from the MCC. All wireways and conduit from the MCC to PBX-P1A and PBX-D1A installed by OTHERS.
5	<b>Influent Water Tank Farm</b>
	Install equipment stanchions (2), SWBD-1100 (480V panelboard), XFMR-ITF-A (5 kVA 480V-120/240V transformer), and LP-ITF-A (120V panelboard).
	Install all conduit, junction boxes, electrical wiring, and supports to connect PBX-P1A and the following panels, components, and infrastructure at the influent water tank farm: SWBD-1100 (480V panelboard), XFMR-ITF-A (5 kVA 480V-120/240V transformer), and LP-ITF-A (120V panelboard). CONTRACTOR to install all conduit and junction boxes mounted on the face of the concrete pad or within concrete trenches to complete connection. Influent Water Tank Farm pad construction including conduit stub-ups/outs by OTHERS. Underground electrical conduit installed by OTHERS will be stubbed out 5 feet from the Influent Water Tank Farm pad where the CONTRACTOR is to complete the connection.
6	<b>Conditioned Water Tank Farm</b>
	Install equipment stanchions (2), SWBD-1400 (480V panelboard), XFMR-CWTF-A (5 kVA 480V-120/240V transformer), and LP-CWTF-A (120V panelboard).
	Install all conduit, electrical wiring, and supports to connect PBX-P1A and the following panels, components, and infrastructure at the conditioned water tank farm: 480V panelboard, XFMR-LP, LP panel, and equipment stanchion. Conditioned Water Tank Farm pad construction including conduit stub-ups/outs and connection to running from the RPWCP at the pad perimeter by OTHERS.
<b>12kV Distribution</b>	
1	Furnish cable, to be installed by OTHERS, for direct burial between PBX-T1A at Node 99 and PBX-T1C at Node 1.
	Perform testing of direct-burial cable installed by others prior to backfill to demonstrate conformance with WORK requirements.
	Install all conduit-encased electrical wiring for 12 kV distribution to connect XFMR-99, XFMR-02, XFMR-03, and XFMR-04 including all connections and grounding at sectionalizing pull boxes. 12kV wiring between XFMR-99 and the Medium Voltage Remote Power Main Breaker is covered under Task 3.2. Installation of underground electrical conduit pull boxes, handholes, and associated penetrations by OTHERS.
<b>480V Distribution</b>	
1	<b>Node 2 Structure</b>
	Node 2 site construction including concrete pads, removable guard posts, grounding system, and sunshade. Installation of underground electrical pull boxes and associated penetrations by OTHERS.
	Install XFMR-02 and SWBD-02.

**TOPOCK REMEDY WORK TASK LIST**

	<p>Install all conduit and supports required to complete 12kV connection at XFMR-02 including excavation, exposed conduit transition, and backfill. Underground electrical conduit installed by OTHERS will be stubbed out 5 feet from the transformer pad where the CONTRACTOR is to complete the connection.</p> <p>Install all conduit, electrical wiring, and supports for electrical connection between XFMR-02 and SWBD-02 including excavation, exposed conduit transitions, and backfill.</p> <p>Install all conduits between SWBD-02 and the Node 2 Communications Panel (to be installed by OTHERS) including excavation, exposed conduit transition, and backfill. CONTRACTOR shall coordinate with the CONSTRUCTION MANAGER to ensure electrical conduit stub-ups are properly located.</p> <p>Install all conduit for connection between the Node 2 Communications Panel (to be installed by OTHERS) and the communications pull box including excavation, exposed conduit transition, and backfill. Underground conduit will be stubbed out 5 feet from the pad by OTHERS where the CONTRACTOR is to complete the connection. CONTRACTOR shall coordinate with the CONSTRUCTION MANAGER to ensure electrical conduit stub-ups at the pad are properly located.</p> <p>Install all conduit and supports required to connect SWBD-02 to underground electrical conduit installed by OTHERS for distribution to IRZ wells including excavation, exposed conduit transition, and backfill. Underground electrical conduit installed by OTHERS will be stubbed out approximately 5 feet from the distribution panel pad where the CONTRACTOR is to complete the connection.</p>
2	<p><b>Node 2 480V Distribution</b></p> <p>Install all electrical wiring from SWBD-02 to IRZ Wells 29, 31, 33, 35, 37, and 39. CONTRACTOR shall leave 10 feet of free-spooled wiring within the well vaults. Installation of underground electrical conduit pull boxes, handholes, well vaults, well vault conduit/panels/disconnects, and associated penetrations by OTHERS.</p> <p>Install all Node 1 electrical wiring as indicated on Sheet E-00-70. Installation of underground electrical conduit pull boxes, handholes, and associated penetrations by OTHERS.</p>
3	<p><b>Node 3 Structure</b></p> <p>Install PNL-03M, XFMR-03, and 480V distribution panels (PNL-03 and PNL-03A) within the MW-20 Bench Carbon Amendment Building Electrical Room including associated grounding. Building construction, including conduit stub ups, by OTHERS. CONTRACTOR shall coordinate with the CONSTRUCTION MANAGER to ensure electrical conduit stub-ups to be installed by OTHERS are properly located.</p> <p>Install all conduit, electrical wiring, and supports to interconnect PNL-03M, XFMR-03, PNL-03, PNL-03A within the MW-20 Bench Carbon Amendment Building Electrical Room.</p> <p>Install all conduit and supports within the MW-20 Bench Carbon Amendment Building Electrical Room from PNL-03A to IRZ well conduit stub-outs installed by OTHERS.</p>
4	<p><b>Node 3 480V Distribution</b></p> <p>Install all electrical wiring from PNL-03A to IRZ Wells 16, 17, 19, 20, 21, 23, 25, and 27. CONTRACTOR shall leave 10 feet of free-spooled wiring within the well vaults. Installation of underground electrical conduit pull boxes, handholes, well vaults, well vault conduit/panels/ disconnects, and associated penetrations by OTHERS.</p>
5	<p><b>Node 4 Structure</b></p> <p>Node 4 site construction including concrete pads, removable guard posts, grounding system, and sunshade. Installation of underground electrical pull boxes and associated penetrations by OTHERS.</p> <p>Install XFMR-04 and SWBD-04.</p> <p>Install all conduit and supports required to complete 12 kV connection at XFMR-04 including excavation, exposed conduit transition, and backfill. Underground electrical conduit installed by OTHERS will be stubbed out approximately 5 feet from the transformer pad where the CONTRACTOR is to complete the connection.</p> <p>Install all conduit, electrical wiring, and supports for electrical connection between XFMR-04 and SWBD-04 including excavation, exposed conduit transitions, and backfill.</p> <p>Install all conduits between SWBD-04 and the Node 4 Communications Panel (to be installed by OTHERS) including excavation, exposed conduit transition, and backfill. CONTRACTOR shall coordinate with the CONSTRUCTION MANAGER to ensure electrical conduit stub-ups are properly located.</p>

TOPOCK REMEDY WORK TASK LIST	
	<p>Install all conduit for connection between the Node 4 Communications Panel (to be installed by OTHERS) and the communications pull box including excavation, exposed conduit transition, and backfill. Underground conduit will be stubbed out 5 feet from the pad by OTHERS where the CONTRACTOR is to complete the connection. CONTRACTOR shall coordinate with the CONSTRUCTION MANAGER to ensure electrical conduit stub-ups at the pad are properly located.</p> <p>Install all conduit and supports required to connect SWBD-04 to underground electrical conduit installed by OTHERS for distribution to IRZ wells including excavation, exposed conduit, and backfill. Underground electrical conduit installed by OTHERS will be stubbed out approximately 5 feet from the distribution panel pad where the CONTRACTOR is to complete the connection.</p>
6	<p><b>Node 4 480V Distribution</b></p> <p>Install all electrical wiring from SWBD-04 to IRZ Wells 1, 5, 9, 11, 13, and 15. CONTRACTOR shall leave 10 feet of free-spooled wiring within the well vault. Installation of underground electrical conduit pull boxes, handholes, well vaults, well vault conduit/panels/disconnects, and associated penetrations by OTHERS.</p>
TCS Site Civil Improvements	
1	<p><b>Retaining Wall</b></p> <p>Earthwork for retaining wall construction including backfill following construction.</p> <p>Install concrete for foundation and retaining wall construction, including installation of weep holes and associated drain rock filter.</p> <p>Install top-mounted hand rail without kickplate.</p> <p><b>NOTE: All intrusive work inside the station fence line to be performed by hydro vacuum or hand excavation method.</b></p>
2	<p><b>Grading and Paving</b></p> <p>General site clearing and grading at the TCS (excludes hillside grading at RPWCP, and earthwork for the backwash/treated water tanks retaining wall).</p> <p>Construct concrete curbs, sidewalks, and equipment pads for heat pump and generator.</p> <p>Install asphalt paving and curbs.</p> <p>Construct gravel roads.</p> <p>Install guard posts</p>
Remedy Produced Water Conditioning Plant (RPWCP)	
1	<p><b>Civil/Site Work</b></p> <p>Earthwork for RPWCP building foundation including demolition of existing hardscape as needed to facilitate construction.</p> <p>Earthwork for decontamination pad foundation including demolition of existing hardscape as needed to facilitate construction.</p> <p>Hillside grading including adjacent to backwash/treated water tanks.</p>
2	<p><b>Building Foundation/Concrete</b></p> <p>Install all underground process mechanical pipelines below the foundation and floor slab. Stub up into building for connection to mechanical equipment. Connect to yard piping stub-out installed by OTHERS at a location no more than 10 feet from building foundation.</p> <p>Install all underground plumbing pipelines below the foundation and floor slab including stub-up into building foundation for connection to plumbing equipment. Connect to Remedy piping installed by OTHERS at a location within 10 feet of the building foundation; exact location of connection to be coordinated with the CONSTRUCTION MANAGER.</p> <p>Install all underground electrical and controls conduit from PBX-P1A and PBX-D1A electrical vaults, adjacent to the building, and stub-up into building foundation for connection to complete electrical work under Task 5.6.</p> <p>Construct concrete foundation, cast-in-place trench walls, slab-on-grade, equipment pads, door landings, concrete ceiling, and exterior stairs with handrail.</p> <p>Install guide channels.</p> <p>Install trench grating.</p>
3	<p><b>RPWCP Building</b></p>

**TOPOCK REMEDY WORK TASK LIST**

	Furnish and install all structural steel framing, metal roof deck, metal standing seam roof, rigid insulation, insulated siding, gutters, and downspouts.
	Install all doors, frames, hardware, louvered openings, glass, and glazing.
	Install 2-ton capacity crane system per approved shop drawings.
	Install steel stud framing, drywall, paint, and cabinetry.
4	<b>HVAC</b>
	Furnish and install exhaust fan at MCC.
	Install Variable Refrigerant Volume (VRV) unit at MCC, Office/Sample Room, and Water Conditioning areas.
	Install heat pump at building exterior.
	Install condensate drains with lamb tongue downspout nozzles and splash blocks
5	<b>Plumbing</b>
	Furnish and install two-compartment sink at Office/Sample Room.
	Install emergency shower and eye wash unit at Water Conditioning and Chemical Storage areas.
	Install electric tankless water heater at Office/Sample Room.
	Install floor drains at Office/Sample Room and Water Conditioning areas.
	Install safe tank for lab drain
6	<b>Electrical</b>
	Furnish and install of all general building electrical including lighting, receptacles, HVAC, hoist, grounding, LP-RWTP-A, LP-RWTP-B and XFMR-RWTP.
	Complete building electrical and coordinate with CONSTRUCTION MANAGER for the energizing of the building. After building is energized, make final connections to 480V-120/240V transformer XFMR-RWTP to power up. <i>Energizing of the building by OTHERS.</i>
	Install all sleeves required for conduit penetrations through concrete for use by OTHERS. Installation of instrumentation/controls panels, conduit, wiring, and devices by OTHERS.
	Install conduits, wireways, and sleeves/entries between PBX-P1A and PBX-D1A, and the Electrical Room for MCC energization. <i>Installation of MCC at Electrical Control Room and wiring for energization by OTHERS.</i> CONTRACTOR to complete connections to MCC at electrical room for energization of LP panelboards and transformer.
7	<b>Process Mechanical</b>
	Install all remediation process piping, valves, pumps, tanks, supports, and equipment.
8	<b>Decontamination Pad</b>
	Construct retaining walls at south and west sides of Decontamination Pad and tie retaining wall into RPWCP building.
	Construct decontamination pad slab-on-grade and sump pit.
	Install sump pit grating.
	Install top mounted hand rail without kick plate per Bid Documents.
	Apply CRC 2 chemical resistant coating to the concrete slab top surface.
9	<b>Switch Gear Pad &amp; Canopy Structure</b>
	Earthwork for foundation construction
	Install underground electrical conduit beneath concrete pad and provide stub-ups and stub-outs for connection by OTHERS.
	Construct concrete foundation and pad.
	Install canopy columns and structural steel components to frame canopy.
	Install standing seam metal roof with 2" rigid insulation and sheet metal siding.
	Install gutters and downspouts.
10	<b>Freshwater Storage Tank Foundation</b>
	Earthwork for foundation and catch basin.
	Construct concrete foundation and catch basin with associated reinforcing steel and tank support anchorage.
	Install grating at catch basin
11	<b>Freshwater Storage Tank</b>
	Furnish and install storage tank, exterior ladder, roof platform, and handrail.
	Install all related process mechanical piping to the storage tank. Instrumentation and controls by OTHERS.

**TOPOCK REMEDY WORK TASK LIST**

	Connect process mechanical piping to underground stub-outs provided by OTHERS at a location within 10 feet of the tank foundation; exact location of connection to be coordinated with the CONSTRUCTION MANAGER.
<b>Influent Water Tank Farm (IWTF)</b>	
1	<b>Civil/Site Work</b> Earthwork, including any required hardscape demolition, clearing, and grading, for IWTF foundation construction.
2	<b>Containment Pad</b> Install conduit stub-ups and stub-outs, including any conduit runs within and/or concealed by the containment pad structure to facilitate electrical and controls installation by OTHERS. Coordinate location of stub-ups and stub-outs with the CONSTRUCTION MANAGER.
	Install grounding for future installation of transformer XFMR-ITF-A. Coordinate location with the CONSTRUCTION MANAGER.
	Construct containment pad foundation, slab-on-grade, cast-in-place trench walls, and concrete flooring.
	Install trench grating.
3	<b>Canopy Structure</b> Construct 8" reinforced concrete masonry wall.
	Install canopy columns and structural steel components to frame canopy.
	Install 1-1/2" standing seam metal roof with 2" rigid insulation.
	Install gutters and downspouts
4	<b>Portable Frac Tanks</b> Install portable frac tanks at the IWTF
<b>Conditioned Water Tank Farm (CWTF)</b>	
1	<b>Civil/Site Work</b> Earthwork, including any required hardscape demolition, clearing, and grading, for CWTF foundation construction.
2	<b>Containment Pad</b> Install Remedy piping stub-ups and stub-outs, including any conduit runs within and/or concealed by the containment pad structure to facilitate electrical and controls installation by OTHERS. Coordinate location of stub-ups and stub-outs with the CONSTRUCTION MANAGER.
	Provide grounding for future installation of transformer XFMR-CWTF-A. Coordinate location with the CONSTRUCTION MANAGER.
	Construct containment pad foundation, slab-on-grade, cast-in-place trench walls, and concrete flooring.
	Install trench grating.
3	<b>Canopy Structure</b> Construct 8" reinforced concrete masonry wall.
	Install canopy columns and structural steel components to frame canopy.
	Install 1-1/2" standing seam metal roof with 2" rigid insulation.
	Install gutters and downspouts.
4	<b>Process Mechanical</b> Install all remediation process piping, valves, pumps, tanks, supports, and equipment in accordance with the Bid Documents. CONTRACTOR to complete connections to underground Remedy piping stub-outs provided by OTHERS at a location within 10 feet of the IWTF containment pad; exact location to be coordinated with the CONSTRUCTION MANAGER. Installation and wiring of instrumentation and controls by OTHERS.
5	<b>Portable Frac Tanks</b> Install portable frac tanks at the CWTF
<b>TCS Ponds</b>	
1	<b>Waste Removal Containment Pad</b> Earthwork, including any required hardscape demolition, clearing, and grading, for Waste Removal Containment Pad construction.
	Construct containment pad slab-on-grade, cast-in-place curb walls, concrete bumps, and sump pit.



TOPOCK REMEDY WORK TASK LIST	
	Install trench grating.
WCS Equipment	
1	Material handling equipment, earthmoving equipment, tank trucks, trucks for tank relocation as appropriate, utility trucks, generators, pumps, hand tools, and other miscellaneous equipment.
Temporary Storage Tanks for Fresh Water	
1	Well Site Fresh Water Storage Tanks
	Mobilization and demobilization ten 3,000-gallon and ten 6,000-gallon tanks on-site at any given time.
	<b>Central Area Fresh Water System</b>
	Mobilization, and setup of up to two 20,000-gallon frac tanks with L-bracket containment
	Piping manifold including all valving and connections to tanks, pumps, and well site piping; piping from the manifold to Remedy wells is included under the Well Site Setup tasks (Tasks 9.X).
	Pumps for water conveyance to from the tank to specified well sites.
Temporary Frac Tanks for Wastewater	
1	<b>Well Site Wastewater Storage Tanks</b>
	Mobilization, cleaning, and demobilization of 20,000-gallon storage tanks for wastewater generated by the Drilling Contractor at a primary work zone. At least six temporary frac tanks onsite at any given time. Tanks should be installed with L-bracket containment berms.
2	<b>Central Area Wastewater Storage System</b>
	Mobilization, and setup of up to six 20,000-gallon frac tanks with L-bracket containment
	Piping manifold including all valving and connections to tanks and well site piping; piping from the manifold to Remedy wells and pumps for conveyance (located at the Remedy well sites) are included under other tasks.
	Cleaning of tanks as part of decommissioning and demobilization.
Stabilization Matting	
1	Mobilization, and demobilization of access road mud mats for construction of drilling access roads to the IRZ and RB wells, and the MW-X and MW-Y wells.
Well Site Setup	
1	Clearing and work area mat installation; installation of BMPs including perimeter controls, spill containment barriers for fresh water, soil cuttings, and waste water transfer; relocation of fresh water and wastewater tanks where required; and construction of temporary pipelines including pumps for well sites as described in the Construction Specifications. Provide stabilization matting for at least 7 primary work areas at any given time.

Source: Topock Remedy Project Request for Proposal (RFP):  
MW-20 Bench, Electrical, TCS Site civil improvements, and WCS  
Equipment

# Topock Phase 2 Construction Work Task Summary

## 1) TCS Pipelines

- a) Pipelines K1, L3, I1, M1 & M2, M6, and N1
  - i) Clearing/Demolition
    - (1) Material Haul-off/Disposal/Storage
  - ii) Excavation
  - iii) Shoring
  - iv) HDPE Pipe, Valves, and Appurtenances Installation
    - (1) Pipe Fusion
    - (2) Pressure Testing
    - (3) Flushing
  - v) Electrical Conduit Installation
    - (1) Mandrel Testing
  - vi) Bedding/Backfilling
    - (1) Material Import
    - (2) Compaction Testing
  - vii) Concrete/Slurry Placement for Duct Bank Encasement
  - viii) CLSM Placement at Existing Utility Crossings
  - ix) Finish Grading and Restoration
  
- b) Pipeline Vaults
  - i) Clearing/Demolition
    - (1) Material Haul-out/Disposal/Storage
  - ii) Excavation
    - (1) Material Haul-off/Storage
  - iii) Vault Placement
  - iv) Poured Floors
  - v) Bedding/Backfilling
    - (1) Material Import
    - (2) Compaction Testing
  - vi) Cast in Place Collars
  - vii) Finish Grading and Restoration

## 2) Non-TCS Pipelines

- a) Pipelines G, C18, E1, and I2
  - i) Clearing/Grubbing/Demolition
    - (1) Material Haul-off/Disposal/Storage
  - ii) Excavation
    - (1) Material Haul-off/Storage
  - iii) Shoring



# Topock Phase 2 Construction Work Task Summary

- iv) HDPE Pipe, Valves, and Appurtenances Installation
    - (1) Pipe Fusion
    - (2) Pressure Testing
    - (3) Flushing
  - v) Electrical Conduit Installation
    - (1) Mandrel Testing
  - vi) Bedding/Backfilling
    - (1) Material Import
    - (2) Compaction Testing
  - vii) Concrete/Slurry Placement for Duct Bank Encasement
  - viii) CLSM Placement at Existing Utility Crossings
  - ix) Bollards
  - x) Finish Grading and Restoration
- 
- b) Pipeline Vaults
    - i) Clearing/Grubbing/Demolition
      - (1) Material Haul-out/Disposal/Storage
    - ii) Excavation
      - (1) Material Haul-off/Storage
    - iii) Vault Placement
    - iv) Poured Floors
    - v) Bedding/Backfilling
      - (1) Material Import
      - (2) Compaction Testing
    - vi) Cast in Place Collars
    - vii) Finish Grading and Restoration

## **APPENDIX K**

### **PG&E Utility Work Procedure 4412P-05 Excavation Procedures for Damage Prevention**



## Excavation Procedures for Damage Prevention

### Summary

This utility procedure provides step-by-step excavation instructions for preventing damage to underground facilities.

Level of Use: Informational Use

---

### Target Audience

All those who perform excavations, including, but not limited to, the following personnel:

- Pacific Gas and Electric Company (Company) gas and electric transmission and distribution (T&D) personnel who perform excavations and their supervisors and superintendents (first party).
  - Contractors performing work for the Company (second party).
  - Third parties.
- 

### Safety

Hazards impacting this work include, but are not limited to, the following conditions:

- Dangerous animals.
- Tripping and slipping hazards.
- Traffic conditions.
- Vegetation, including poison oak.
- Environmental surroundings.
- Electrical shock.
- Construction sites.

The excavation tasks in this document are the minimum required procedures. In some situations, additional precautions may be necessary to ensure the safety of personnel, the public, and facilities. Always use caution to avoid damage to underground facilities and ensure a safe work environment.

---

### Before You Start

#### Personal Protective Equipment (PPE):

Field personnel following this procedure must wear the following PPE at a minimum, plus any other applicable PPE, as specified in the [Code of Safe Practices](#):

- Hard hat (must be available).
-



## Excavation Procedures for Damage Prevention

- Traffic vest.
- Proper work footwear, no sneakers allowed.
- Long-sleeved shirt.
- Long pants.
- Gloves (must be available).
- Safety glasses (must be available).

### **Training and Qualifications:**

- Personnel performing excavation must be trained and qualified to operate excavation equipment and must be able to read and understand Company facility maps.
- A designated standby person must be qualified for [operator qualification \(OQ\)](#) subtask OQ 05-02, "Standby Pipeline."

### **Tools, Materials, and Equipment:**

The following tools are required to perform the procedures in this document:

- Communication device (i.e., radio, cell phone).
- Camera.
- Shovel.
- Fiberglass T-handled probe with ball tip.

Excavators must have the following materials:

- Map for reference.
- Electronic marker system (EMS) supply of all depths (3 feet [ft], 6 ft, etc.).
- Copy of current underground service alert (USA) ticket.
- White chalk, white flags, white stakes, white whiskers.

The following are examples of equipment used to perform excavations:

- Backhoes.
- Vacuum excavation trucks.
- Boring equipment.
- Pole augering equipment



## Excavation Procedures for Damage Prevention

### Table of Contents

Subsection	Title	Page
1	Preparing for an Excavation .....	3
2	Performing Excavations .....	5
3	Performing Emergency Excavations .....	6
4	Excavating near Critical Facilities.....	7
5	Excavating near High-Priority Facilities .....	7
6	Inspecting Exposed Underground Facilities .....	9
7	Dry-Bore Inspecting: Horizontal Earth Boring.....	10

### Procedure Steps

#### 1 Preparing for an Excavation

1.1 An excavator must perform the following steps before proceeding with an excavation:

1. Delineate the excavation area with white chalk, flags, stakes, whiskers, or other suitable markings, including a Company identifier (name, abbreviations, or initials).
2. Contact USA personnel (811) to obtain a USA ticket number at least 2 working days, but not more than 14 calendar days, before starting excavation.
3. Obtain the contact information from USA personnel for all facility owners/operators notified by USA personnel and listed on the USA ticket.
4. Request and obtain a response (by phone, fax, email, or surface markings at the job site) from each known facility owner/operator within the excavation area providing the following information:
  - Confirmation that the operator or owner has located their underground facilities.
  - The location of their underground facilities OR notification that those facilities pose no conflict with performing the proposed excavation.
5. IF intending to use boring, vacuum excavation equipment, or explosives for the excavation,

THEN perform the following tasks:

- a. Notify USA personnel of that intention by phone or online so that it is stated on the USA ticket.



## Excavation Procedures for Damage Prevention

### 1.1 (continued)

- b. Obtain permission to use the intended excavation method from each facility owner/operator whose facilities are in conflict with the proposed work location. (Each facility owner/operator must evaluate the proposed work and provide permission to the excavator if approved.)

- c. IF blasting is to be used,

THEN consult the responsible engineer, who must follow the gas piping technology committee (GPTC) *Guide for Gas Transmission and Distribution Systems*, Appendix G-192-16, to determine whether blasting is allowed and what precautions or protections are necessary. (To access the *GPTC Guide*, install WINDOT from the internet location [http://www/TechLib/default.asp?body=all\\_go\\_regs.htm](http://www/TechLib/default.asp?body=all_go_regs.htm).)

### NOTE

Each excavator at a job site must have a separate, valid USA ticket.

6. Obtain a hard copy of the valid USA ticket, ensure that the excavator specified on the ticket is correct, AND keep the hard copy available at the job site.
7. Ensure that any contractor performing an excavation has a hard copy of a valid USA ticket at the job site.
8. IF the facility owner/operator does not respond before the excavation start date and time,  
  
THEN notify USA personnel. (See the [USA North California Excavation Manual](#) for more information related to California Government Code (CGC) rules and regulations.)
9. IF underground facilities belonging to non-USA members are known or suspected to be within the delineated area,  
  
THEN perform the following tasks:
  - a. Contact the facility owner/operator. (USA personnel may be able to provide assistance with obtaining contact information for non-USA members.)
  - b. Request that the owner/operator see that the facility is marked and located.
  - c. Document all contacts and conversations.
10. IF a facility owner/operator does not respond before the excavation start date and time,  
  
THEN notify USA personnel. (See the [USA North California Excavation Manual](#) for more information related to CGC rules and regulations.)



## Excavation Procedures for Damage Prevention

### 1.1 (continued)

11. IF excavating on private property or in an easement,  
THEN notify the property owner or tenant.

## 2 Performing Excavations



Damage to underground facilities may occur if excavations are performed without a current USA ticket. USA tickets are valid for 28 days from the date issued.

- 2.1 Ensure that a hard copy of the current USA ticket listing the excavator performing the excavation is at the job site. (IF there is more than one excavator, THEN each must have a separate, valid USA ticket.)
- 2.2 Ensure that a response is received from every underground facility owner listed on the USA ticket.
- 2.3 Always hand dig to find the outermost edge of an underground facility.
- 2.4 Perform the tasks listed below that are appropriate for the excavation in progress:
  - When digging near third-party underground facilities, do not use power-operated equipment (including vacuum excavation) within 24 inches (in.) of the outermost edge of an underground facility unless the owner/operator of the facility agrees to allow power-operated equipment closer than 24 in.
  - When digging near Company-owned underground facilities, follow the instructions in [Attachment 1, "Prospecting Around Pacific Gas and Electric Company \(Company\)-Owned Facilities."](#)
  - When boring during an excavation, first expose the exterior surfaces of all known underground facilities in the bore path. (See [Attachment 1](#) for specific requirements.)
  - When it is necessary to access covered (slurry, concrete, or other cementitious materials) pipelines, perform the following tasks:



Removing the covering material over a pipeline when gas is present can result in damage to facilities or harm to personnel or the public.

1. Check for gas leaks before beginning the excavation.



## Excavation Procedures for Damage Prevention

### 2.4 (continued)

2. IF gas is detected,

THEN do not attempt to remove the covering material AND immediately notify the supervisor;

OTHERWISE, go to Step 3 below.

3. Remove the covering material from around the pipeline with pneumatic tools or hand tools while monitoring the immediate location for gas leaks.
4. Check for gas leaks after the covering material is removed.
5. IF gas leaks are found,

THEN immediately notify the supervisor and obtain instructions on how to proceed.

- When a pipeline is exposed during an excavation, protect, support, or remove exposed pipeline spans to safeguard personnel and facilities according to the appropriate instructions listed below:
  - For steel gas pipelines, refer to [Attachment 2, "Maximum Unsupported Steel Pipe Span Length and Excavating Pipe with Increased Axial Stresses and Anomalies"](#) for information.
  - For pipeline materials other than steel or steel pipeline spans that exceed the allowable lengths specified in [Attachment 2](#), contact the responsible gas engineer to determine allowable span lengths and to determine acceptable support methods.

- 2.5 Immediately notify the owner of a subsurface facility upon discovering or causing damage to that facility, including all breaks, leaks, nicks, dents, gouges, grooves, or other damage to subsurface installation lines, conduits, coatings, or cathodic protection.

### 3 Performing Emergency Excavations

- 3.1 The excavator must perform the following steps before performing an emergency excavation:

1. Contact USA personnel during regular business hours (6 A.M. to 7 P.M. Pacific Time) if the emergency occurs during those hours, or when USA opens the next morning if it occurs after normal business hours.
2. Attempt to contact any known underground facility owners in the excavation area before excavating.
3. IF any facility owners cannot be reached,

THEN document the attempt and continue with the excavation.





## Excavation Procedures for Damage Prevention

### 4 Excavating near Critical Facilities

- 4.1 Do not excavate within 5 ft of either side of the exterior surface of a critical facility without a designated and qualified standby person present. (See [Utility Procedure WP4412-04, "Field Meets and Standby – Damage Prevention,"](#) for instructions on using a standby person.)

### 5 Excavating near High-Priority Facilities

- 5.1 The excavator must perform the following steps when excavating near high-priority facilities:

1. See [WP4412-04](#) for field meet and standby requirements.
2. Do not excavate within 10 ft of an identified high-priority facility before holding an on-site field meet with the facility owner/operator.
3. IF the underground facility is suspected to be in unstable soil 5 ft deep or deeper,  
  
THEN slope, bench, or shore the excavation in compliance with [UO Standard S4415, "Excavation Safety."](#)
4. Provided no facilities are contained within the pavement, use power-operated equipment to remove pavement as needed and appropriate.
5. Review the map and identify all fittings and attachments to the pipe that could be within the delineated area (e.g., bottom taps, pressure control fittings, service tees, elbows, drips, stubs).
6. When suspecting that fittings or attachments are within the proposed excavation area, physically locate them by performing the following steps:
  - a. IF the proposed excavation is within 2 ft of the outer edge of the facility,  
  
THEN perform the tasks in this section to expose the facility along the entire length of the excavation;  
  
OTHERWISE, go to Step 6.b below.

#### NOTE

[Figure 1, "High-Priority Facility Excavation,"](#) on the next page illustrates digging parameters and is marked with numbers correlating to the tasks below.

- (1) Physically locate the facility.
- (2) Perform the appropriate steps in [Attachment 1](#) to confirm that the surface marks are correct.

## Excavation Procedures for Damage Prevention

5.1 (continued)

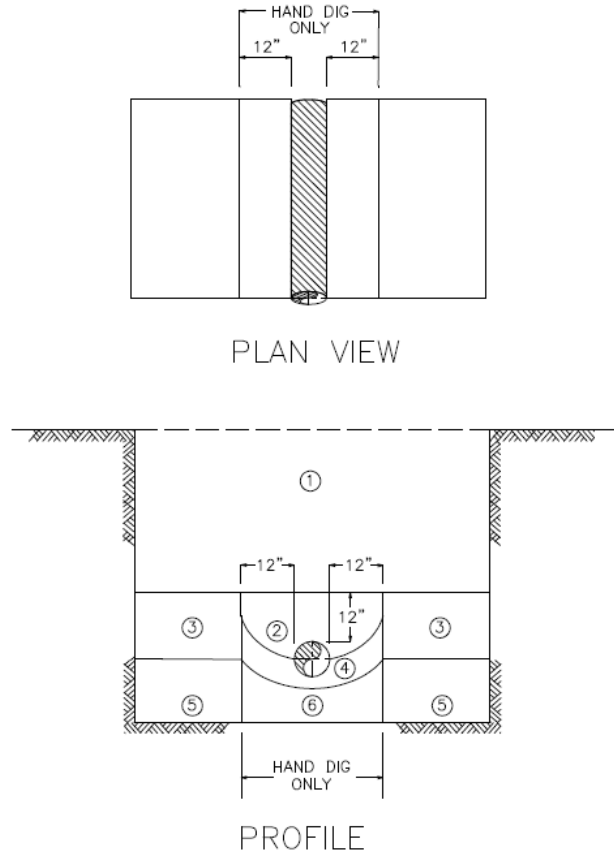

**Figure 1. High-Priority Facility Excavation**

- (3) Once the marks are confirmed, expand the excavation to the extent of the overall excavation.
- (4) Continue following the prospecting procedure at enough locations within the overall excavation area to ensure that all possible horizontal or vertical offsets (i.e., sags, overbends, or changes in direction) are identified.

### NOTE

Any digging done within 12 in. of the facility **must** be done by hand.

- (5) Hand-dig to expose the side of the facility along the entire length of the proposed excavation AND identify possible fittings or attachments that may extend from the side of the facility.



## Excavation Procedures for Damage Prevention

### 5.1 (continued)

- (6) IF no other facilities are present,  
  
THEN it is permissible to use power-operated equipment to remove soil along the side of the facility to a depth no greater than the depth reached in [Step \(5\)](#) above.
  - (7) Hand-dig to expose the bottom of the facility along the entire length of the proposed excavation AND identify possible fittings or attachments that may extend from the bottom of the facility.
  - (8) IF no other facilities are present,  
  
THEN it is permissible to use power-operated equipment to remove soil along the side of the facility to the desired depth;  
  
OTHERWISE, hand dig to remove the soil along the side of the facility.
  - (9) Hand dig to remove the remaining soil below the facility.
- b. IF the proposed excavation is within 2 ft to 5 ft, inclusive, of the nearest side of a critical facility,
- THEN perform the following tasks:
- (1) Physically locate the facility.
  - (2) Perform the appropriate steps in [Attachment 1](#) to confirm that the surface marks are correct AND are at enough locations to provide confidence in the surface markings.
  - (3) Do not exceed 100 ft between prospecting locations.

## 6 Inspecting Exposed Underground Facilities

### 6.1 A crew may take the following actions as required:

1. Install an EMS on underground facilities that cannot be located by means other than exposing them.
2. To make it easier to locate gas underground facilities with a maximum allowable operating pressure (MAOP) greater than 60 pounds per square inch gauge (psig), perform the following tasks:
  - a. Consider installing an electrolysis test station (ETS) per [Numbered Document O-16, "Corrosion Control of Gas Facilities."](#)



## Excavation Procedures for Damage Prevention

6.1 (continued)

b. IF installing an ETS,

THEN contact gas engineering personnel for spacing requirements.

3. On gas distribution pipelines that are difficult to locate, consider installing an ETS.

6.2 If excavations have occurred without a USA ticket within 2 ft of the outermost edge of the underground facility,

THEN the following tasks must be performed:

1. The excavator must uncover and inspect the underground facilities to check for mechanical damage.

2. A qualified Company inspector must verify whether there is any damage to Company facilities.

6.3 Persons performing inspections must fill out the inspection form, [Form 62-4060, "Leak Survey, Repair, Inspection and Quarterly Incident Report \(A Form\)."](#)

### 7 Dry-Bore Inspecting: Horizontal Earth Boring



#### CAUTION

Damage to underground facilities may occur if excavations are performed without a current USA ticket.

7.1 Perform camera inspections for all dry horizontal earth boring (dry-bore) to confirm that there is no damage to existing underground facilities.

7.2 Expose the exterior surfaces of all known underground facilities in the bore path.

7.3 When performing horizontal directional drilling (HDD), do so in accordance with the [Horizontal Directional Drilling Manual](#).

7.4 Perform dry-bore camera inspections in accordance with [Attachment 3, "Dry-Bore Inspection Methods Using an Inspection Camera System,"](#) and the following required actions:

1. IF damage to underground facilities is identified during a dry-bore inspection,

THEN follow all Company procedures for damage to underground facilities, including but not limited to the procedures in the following documents:



## Excavation Procedures for Damage Prevention

### 7.4 (continued)

- SHC 101 - Property Damage and Third Party Injuries.
- SHC 102 - Evidence Acquisition and Storage.
- Utility Procedure TD-1465P-02, "Gas Event Reporting."

2. IF bore hole inspection is not possible,

THEN perform the following tasks:

- a. Document the reason no inspection is possible and provide signoff from the supervisor or local engineer when filling out the form in [Step 3](#) below.
- b. Contract a third party inspection company (e.g., plumber, sewer company) to inspect all sewer mains, sewer laterals, and storm drains in the vicinity of the bore path.
- c. IF a third-party inspection company is not available,  
  
THEN call Gas Transmission Systems Inc. (GTS) at **1-925-478-8100** AND leave a call-back name and number to schedule a third-party inspection.

3. Document all dry-bore inspections on [Form TD-4412P-05-F01, "Cross Bore Prevention Log"](#) according to the following instructions:

- a. Complete Section 1 on the form for all dry-bores performed.
- b. Complete one or more of the following sections on the form:
  - Section 2 with bore hole inspection camera results.
  - Section 3 with sewer or storm drain inspection camera results OR note in the comments box that GTS has been contacted and inspection scheduled.
  - Section 4 with supervisor or local engineering signoff AND the reason for "no inspection possible."

7.5 Scan all [TD-4412P-05-F01](#) forms weekly and route them to the following email address: [crossbore@pge.com](mailto:crossbore@pge.com).

**END of Instructions**



## Excavation Procedures for Damage Prevention

### Definitions

**Boring:** Horizontal directional drilling, augering, tunneling, or other trench-less technologies.

**Common Ground Alliance (CGA):** A member-driven association dedicated to ensuring public safety, environmental protection, and the integrity of services by promoting effective damage prevention practices.

**Critical facilities:** For the purposes of this procedure, all gas transmission pressure (above 60 psig) facilities and all electric facilities operating at or above 60 kilovolt (kV). The following facilities may also be critical facilities:

- Facilities identified as critical by the local operating area.
- Facilities which, if damaged, are likely to result in difficulty controlling the gas flow due to their size, material properties, operating pressure, or location, as well as the personnel and equipment available.
- Electric distribution facilities which, if damaged, are likely to result in outages of long duration or outages to critical customers.

**Damage:** Includes breaks, leaks, nicks, dents, gouges, grooves, or other damage to underground lines, conduits, coatings, or cathodic protection. (See [California Government Code §4216.4\[c\]](#).)

**Emergency:** A sudden, unexpected occurrence involving a clear and imminent danger and demanding immediate action to prevent or mitigate loss of life, health, property, or essential public services. Unexpected occurrences include but are not limited to fires, floods, earthquakes or other soil or geologic movements, riots, accidents, damage to a subsurface installation requiring immediate repair, or sabotage. (See [California Government Code §4216\[d\]](#).)

**Electronic marker system (EMS):** Devices encased in polyethylene housings that use passive antennas until they are activated by a locating instrument operating at a frequency compatible with that of the markers' antennas. These devices are installed on or adjacent to underground infrastructure to facilitate locating.

**Covered pipeline:** A natural gas pipeline or service that is located within or encapsulated by slurry, concrete, or any other cementitious material.

**Electrolysis test station (ETS):** A structure to house test wires that are bonded to buried metallic piping or structures. These wires are run up to the ETS in a location normally at or above ground to test the adequacy of the cathodic protection system.

**Excavation:** Any operation in which earth, rock, or other material in the ground is moved, removed, or otherwise displaced with tools, equipment, or explosives by any method, including but not limited to blasting, boring, backfilling, removal of aboveground structures by either mechanical or explosive means, grading,



## Excavation Procedures for Damage Prevention

trenching, digging, ditching, drilling, augering, tunneling, scraping, or cable or pipe plowing and driving.

**Field meets:** Prearranged meetings between the locator and excavator to inform the excavator of the location of and danger posed by Company facilities and clarify any questions the excavator has for the Company regarding its facilities or the timetable for the excavation.

**Gas Pipeline Technology Committee (GPTC):** A national committee of industry and governmental representatives that provides technical guidance on natural gas issues.

**High-priority facilities:** Any of the following facilities (see [California Government Code §4216\[e\]](#)):

- High-pressure natural gas pipelines with normal operating pressures greater than 415 kilopascal (kPA) gauge (60 psig).
- Petroleum pipelines.
- Pressurized sewage pipelines.
- High-voltage electric supply lines, conductors, or cables that have a potential to ground of greater than or equal to 60 kV.
- Hazardous materials pipelines that are potentially hazardous to workers or the public if damaged.

**Maximum allowable operating pressure (MAOP):** The maximum pressure at which a pipeline, pipeline segment, or component is qualified to operate in accordance with the requirements of [49 CFR Part 192](#).

**Positive response (positive contact):** Response from a facility owner/operator providing requested information, including the following information:

- The location of an underground facility, identified by locating and field marking the approximate location.
- If known, the number of subsurface installations that may be affected by the excavation

Responses are as extensive and accurate as the available information, which is either found in the records of the owner/operator or determined through the use of standard locating techniques other than excavating.

Otherwise, the facility owner/operator advises the person who contacted the one-call center of the location of the owner/operator's underground facilities, installations that may be affected by the excavation, or that the owner/operator does not operate any underground facilities that would be affected by the proposed excavation.



## Excavation Procedures for Damage Prevention

**Power-operated equipment:** Any power-operated or power-driven tool or device. See [Attachment 1](#) for details.

**Probing:** A method of physically locating buried gas facilities before using power-operated equipment. See [Attachment 1](#) for details.

**Third-party facilities:** Facilities owned and operated by parties other than the Company.

**Underground Service Alert (USA):** Regional one-call notification centers for the Company service territory. There are two centers serving the Company: [Underground Service Alert of Central/Northern California and Nevada \(USA North\)](#) and [Underground Service Alert of Southern California \(USA South\)](#).

**USA ticket:** A document created when an excavator calls USA personnel to request underground facility locations before excavating.

---

### Implementation Responsibilities

Maintenance and construction supervisors must ensure that personnel are familiar with and follow this procedure.

---

### Governing Document

[Utility Standard S4412, "Preventing Damage to Underground Facilities,"](#) governs this document.

---

### Compliance Requirement/Regulatory Commitment

[49 CFR 192.703 \(b\) and \(c\) General](#)

---

### Reference Documents

**Developmental References:**

NA

**Supplemental References:**

[California Government Code §4216](#)

[California Code of Regulations, Title 8, Subchapter 4, "Construction Safety Orders," Article 6, "Excavations"](#)





## Excavation Procedures for Damage Prevention

[Code of Federal Regulations, 29 CFR 1926.651\(b\)\(4\): "Safety and Health Regulations for Construction," Subpart P, "Excavations: Specific Excavation Requirements"](#)

[Code of Safe Practices](#)

[Common Ground Alliance Best Practices](#)

Company Forms:

[Form 61-0548 "Gas Dig-In Incident Report \(Form A1\)"](#)

[Form 62-4060, "Leak Survey, Repair, Inspection and Quarterly Incident Report \(A Form\)"](#)

[Excavation Safety Manual](#)

GPTC *Guide for Gas Transmission and Distribution Systems*,  
Appendix G-192-16: [http://www/TechLib/default.asp?body=all\\_go\\_regs.htm](http://www/TechLib/default.asp?body=all_go_regs.htm)

[Numbered Document O-16, "Corrosion Control of Gas Facilities"](#)

[USA North's California Excavation Manual](#)

[Utility Standard Practice \(USP\) 22, "Safety and Health Program"](#)

Utility Standards:

[S4412, "Preventing Damage to Underground Facilities"](#)

[S4415, "Excavation Safety"](#)

Utility Procedures:

[WP4412-01, "Operating Procedures for Locating Instruments"](#)

[WP4412-02, "Locating Instruments Calibration Verification and Repair Procedures"](#)

[TD-4412P-03, "Marking and Locating PG&E Underground Facilities"](#)

[WP4412-04, "Field Meets and Standby for Damage Prevention"](#)

---

### Appendices

NA

---



## Excavation Procedures for Damage Prevention

### Attachments

[Attachment 1, "Prospecting Around Pacific Gas and Electric Company \(Company\)-Owned Facilities"](#)

[Attachment 2, "Maximum Unsupported Steel Pipe Span Length and Excavating Pipe with Increased Axial Stresses and Anomalies"](#)

[Attachment 3, "Dry-Bore Inspection Methods Using an Inspection Camera System"](#)

[Form TD-4412P-05-F01, "Cross Bore Prevention Log"](#)

### Document Revision

This utility procedure cancels and supersedes the following documents:

- Work Procedure WP4412-05 "Excavation Procedures for Damage Prevention," dated 08/2009.
- Gas Information Bulletin TD-4412B-005 "Changes to WP4412-05, "Excavation Procedures for Damage Prevention," dated 8/2011.
- Gas Information Bulletin TD-4412B-009, "Dry Bore Inspection Requirements," dated 11/2011.

### Approved By

Karen Roth  
Director

### Document Owner

Chris McGowan

### Document Contact

Chris McGowan



## Excavation Procedures for Damage Prevention

### Revision Notes

Where?	What Changed?
Entire procedure.	Put into new template according to current writing style.
1.1 Step 5	Added requirement before excavating when intending to use boring, vacuum excavation equipment, or explosives for the excavation.
2.5	Added instruction to notify facilities owners if damage is discovered or occurs.
6.2	Added instruction to inspect exposed underground facilities when excavation has occurred within 2 ft of the outermost edge of the facilities.
Definitions	Revised definition of excavation
Section 7	Added section about dry-bore inspection
Attachment 3	Added Attachment 3, "Dry-Bore Inspection Methods Using an Inspection Camera System"
Form TD-4412P-05-F01	Made minor editorial corrections to form and designated as Attachment 4.

## **APPENDIX L**

### **PG&E Utility Standard ENV-9201S Utility Identification and Strike Avoidance Standard**



## Utility Identification and Strike Avoidance Standard

### Summary

This standard describes the requirements for identifying the location of utilities at Pacific Gas and Electric Company (PG&E) remediation project sites prior to beginning work that might come into contact with those utilities. The utilities include underground, overhead, and embedded utilities (utilities present within structure foundations and walls). Underground, overhead, and embedded utilities can pose serious potential safety hazards to personnel, the public and the environment during site investigation and remediation work. It is therefore required that all utilities that could be impacted by an investigation or remediation project be identified and marked prior to any soil disturbance or penetration activities.

Examples of utilities that could be encountered include underground and overhead electrical lines, gas lines, water lines, communications cables, sanitary and storm sewers, and hazardous materials pipelines, as well as live electric, gas, and communication lines embedded in structure foundations and walls.

In addition, employees who may be exposed to excavation hazards involving underground utilities must be trained in applicable notification and excavation practices incorporating requirements in the California Government Code (CGC), Sections 4216 through 4216.9.

### Target Audience

Utility and contract employees involved in environmental remediation projects including:

- PG&E Environmental Remediation Project Managers, including contract project managers (PM)
- PG&E Environmental Remediation Managers (MGR)
- PG&E Environmental Remediation Safety & Compliance Principal)
- PG&E Environmental Remediation Prime Contractors (PC)
- Other Contractors working directly for PG&E or under contract to a PC.

### Safety

Failure to follow the work practices described in this standard may result in personal harm (including the general public), property damage, utility outages, operational delays, noncompliance of external regulations, potential impacts to the environment, and violation of the company's Code of Safe Practices.



## Utility Identification and Strike Avoidance Standard

### Table of Contents

Subsection	Title	Page
1	Compliance .....	2
2	Waivers and Exemptions .....	2
3	Private Property Contact .....	3
4	Penetration Activities .....	3
5	Marking Criteria .....	4
6	Excavation/Soil Boring Precautions .....	5
7	Training .....	6
8	Quality Reviews .....	6

### Requirements

#### 1 Compliance

- 1.1 Utility mark and locate operations must comply with all applicable Federal, State, and Local laws, rules and regulations, including, but not limited to, CGC Section 4216 and Title 8 Code of California Regulations Section 1541. In addition, PG&E employees and PCs must follow the applicable PG&E Standards and Work Practices referenced herein.
- 1.2 All excavation and penetration activities where there is a reasonable possibility that underground installations may be present, regardless of location, require Underground Service Alert (USA) notification within the required time frames. The USA notification is the initiating event for utility owners to provide mark and locate services.
- 1.3 Excavation and penetration activities may not proceed without a current USA Ticket AND a response from every underground facility owner listed on the USA Ticket.
- 1.4 Remediation contractors must also provide a 3<sup>rd</sup> party locate using other means of identifying anomalies with technology such as Ground Penetrating Radar or other means that have been reviewed and approved by the PG&E PM. This is mandatory; especially when crews are working beyond the Meter. USA Alert's locates DO NOT ALWAYS COVER EVERYTHING PAST THE METER. Only under certain conditions is a 3<sup>rd</sup> party locate waived. These conditions are included below under Section 2.

#### 2 Waivers and Exemptions

The private 3<sup>rd</sup> party utility locate requirement may be waived upon the PG&E PM's confirmation that one of the following situations apply:



## Utility Identification and Strike Avoidance Standard

- Excavation and penetration activities are being performed at a site where there is NOT a reasonable possibility that underground installations may be present (e.g., remote/rural or greenfield locations).
- Excavation and penetration activities are being performed at a site where performance of the 3<sup>rd</sup> party utility locate is not technically feasible (e.g., inundated wetland or hilly forested terrain).
- Sites where all planned excavation/penetration locations have been previously evaluated using a 3<sup>rd</sup> party utility locator and the project team can confirm that there have been no changes within the planned excavation/penetration footprint since that time.
- The scope of work ONLY includes:
  - The use of non-conductive sampling tools to excavate to a depth of 6 inches below ground surface (BGS) or less;
  - Placement of survey flagging to a depth of 6 inches BGS or less; or
  - Placement of non-conductive survey stakes to a depth of 6 inches BGS or less.

If the PG&E PM determines that none of these waiver conditions apply, but still feels that that the 3<sup>rd</sup> party locate should be waived for another reason, they should consult the Compliance Principal for concurrence.

### 3 Private Property Contact

- 3.1 USA notification is required for excavations on private property. The property owner must be notified, and any information regarding buried facilities on site must be requested.

### 4 Penetration Activities

- 4.1 USA notification must be made for all penetration activities that meet the definition of excavation. However, due to the nature of many structures, USA members may not identify all or any utilities present within foundations or walls. Therefore, 3<sup>rd</sup> party locate services must be provided prior to start of work.
- 4.2 Every effort must be made to obtain as-built drawings for the structure. Third-party locaters are required, if at all possible, to use Active Electromagnetic Resistivity (ER) methods, and must make every effort to identify breaker boxes, wall outlets, switches, and other items that might identify and provide access to active electric, phone, sewer, water and other utilities.
- 4.3 IF penetration activities are to be performed within 2 feet horizontally of any identified utilities, THEN the utilities must be de-energized or otherwise isolated. Proper Lock Out/Tag Out procedures will be employed and confirmed prior to initiating the penetration activities.
- 4.4 IF penetration activities are to be performed within 2 feet horizontally of any identified utilities, BUT the utility cannot be de-energized or isolated, THEN the penetration activity is moved to an alternate location; **or**



## Utility Identification and Strike Avoidance Standard

IF the penetration activity cannot be moved to an alternate location,

THEN proper grounding techniques are applied to the penetrating equipment and grounding mats will be used for personnel.

4.5 IF the third-party locator is unable to locate utility tie-in points for an active ER survey,

THEN the 3<sup>rd</sup> party notifies the PG&E PM prior to using alternative methods, and provides justification for decision that active ER is not possible.

### 5 Marking Criteria

5.1 Marking is performed only by qualified utility owners or 3<sup>rd</sup> party locate contractors. PG&E Environmental Remediation staff, contractors (except for qualified mark and locate contractors) and consultants will not perform utility location marking. The marking criteria are listed below.

#### Color Code Identifiers (APWA Uniform Color Code)

<b>Red</b>	Electric
<b>Yellow</b>	Gas/oil/steam
<b>Orange</b>	Telephone/communications/cable TV
<b>Blue</b>	Water
<b>Green</b>	Sewer
<b>Purple</b>	Reclaimed water and slurry
<b>White</b>	USA delineation area (proposed excavation area)
<b>Pink</b>	Temporary survey markings

5.2 Marks are lines or arrows typically about 12" in length and may be spaced up to 50 feet apart depending on site conditions.

5.3 The marks are placed over the center of the utility. Depending on the structure diameter, the utility may exist below ground at a specific distance on either side of the mark. (For example, if a mark is placed on the ground indicating the presence of a 12" diameter pipe, the sides of the pipe may extend 6" on either side of the mark.)

5.4 For safety reasons, per the CGC, depths of the utility structure below ground are not provided.







5.5 The company or agency's initials are placed near the markings designating its utilities at least one time per excavation site.





## Utility Identification and Strike Avoidance Standard

- 5.6 Gas facility locations, must be marked indicating line pressures, pipe diameter and material of construction, if known.
- 5.7 Examples of gas line pressure and construction material markings are as follows:
- TP = Transmission Pressure (> 60 psi)
  - DP = Distribution Pressure (≤ 60 psi)
  - STL = Steel Pipe
  - PL = Plastic Pipe
- 5.8 Electric utility locations must be marked with the size and number of ducts, as well as other markings for insert casings (per Utility Work Procedure WP4412-03).
- 5.9 Utility Marking Examples: (Arrows and markings would be red for electrical, yellow for gas, blue for water, green for sewer, orange for communication).

<b>PG&amp;E</b>  <b>4" DP PL</b>  <b>(4" plastic gas distribution line)</b>	<b>PG&amp;E</b>  <b>2 - 4" Ducts</b>  <b>(Two 4" electrical ducts)</b>	<b>PG&amp;E</b>  <b>24" TP STL</b>  <b>(24" steel gas transmission line)</b>	<b>PG&amp;E</b>  <b>1/2" DP PL</b>  <b>(half-inch plastic gas distribution line)</b>
	  <b>(No PG&amp;E electric utilities present)</b>	  <b>(No PG&amp;E gas utilities present)</b>	

## 6 Excavation/Soil Boring Precautions

- 6.1 All excavation activities near, adjacent to, or around utilities must follow [PG&E Utility Procedure WP4412-05](#). This Work Procedure applies to any excavator, including, but not limited to:



## Utility Identification and Strike Avoidance Standard

- PG&E personnel;
- PCs performing work for PG&E; and
- All third parties.

6.2 Work Procedure 4412-05 (with two attachments) includes requirements for the following operations and circumstances:

- Emergency excavation procedures, access to closest hospital and 911
- Excavating within 5 feet of a Critical Facility;
- Excavating within 10 feet of a High Priority Facility;
- Excavating within 2 feet of a High Priority Facility (requiring facility exposure);
- Excavating between 2 feet and 5 feet from the nearest edge of a Critical Facility;
- Special circumstances for borings;
- Supporting exposed pipelines;
- Accessing covered pipelines;
- Prospecting around PG&E owned utilities;
- Physically locating PG&E owned utilities using vacuum excavation, including air knife;
- Physically locating PG&E owned utilities by probing (steel gas facilities only);
- Physically locating PG&E owned utilities by hand excavation; and
- Maximum unsupported steel pipe span length within an excavation.

6.3 The PG&E PM must confirm, in writing, that the PC has reviewed the Utility Mark and Locate Consultant Advisory.

### **7 Training**

7.1 PMs are trained in accordance with this standard.

7.2 Training is conducted within 60 days of initial assignment as PM, and as needed thereafter.

7.3 Training is provided by the Safety & Compliance Principal or his/her designate.

### **8 Quality Reviews**

8.1 The Safety & Compliance Principal and the PMs are responsible for conducting periodic quality assurance reviews to ensure that PCs and contractors comply with this standard.

**END of Requirements**



## Utility Identification and Strike Avoidance Standard

### Definitions

**Critical Facilities:** All gas transmission pressure (above 60 psig) facilities and all electric facilities operating at and above 60 kilovolt (kV) are considered “critical facilities” for the purpose of this WP. Critical facilities may also be determined by the local operating area and include those facilities which, if damaged, are likely to result in difficulty controlling the gas flow due to the size, material properties, operating pressure, and/or location of the facility. When determining the difficulty of controlling gas flow, give consideration to employee and equipment availability. Critical facilities also include electric distribution facilities which, if damaged, are likely to result in extensive (long duration) outages or outages to critical customers.

**Excavation:** Any operation in which earth, rock, or other material in the ground is moved, removed, or otherwise displaced by means of tools, equipment in any of the following ways: grading, trenching, digging, blasting, ditching, drilling, auguring, boring, tunneling, scraping, or any other way.

**High Priority Facilities:** High pressure natural gas pipelines with normal operating pressures greater than 415 kilopascal (kPA) gauge (60 psig), petroleum pipelines, pressurized sewage pipelines, high-voltage electric supply lines, conductors, or cables that have a potential to ground of greater than or equal to 60 kV, or hazardous materials pipelines that are potentially hazardous to workers or the public, if damaged.

**Marking:** A designation on the ground indicating the location underground utilities and the location of proposed subsurface work.

**Penetration:** For purposes of this Standard, any coring, cutting, drilling, grinding, or other activity that intrudes into any structure foundation or wall where utilities may be present within the structure.

**Remote/Greenfield Site:** A site (or portion of the site) that is situated in remote/rural or wilderness areas, where ONLY hand digging or hand augering is to be conducted. Must not (1) have evidence of anthropogenic activity; (2) have been previously used for commercial purposes; (3) be within 1 kilometer of a developed area; and (4) be within 100 meters of an isolated habitation dwelling. Must be confirmed in the field by completing a site walk and visual clues survey.

**Underground Service Alert (USA):** Regional one-call notification centers for the Company service territory. There are two centers serving the Company: Underground Service Alert of Northern California (USAN) and Underground Service Alert of Southern California (USAS). May be contacted by calling 811.

**Utility:** Any underground or aboveground pipe, wire, facility or infrastructure used in the conveyance of energy, material, commodity, waste, or service. Utilities include, but are not limited to electrical lines, cable boxes, manholes, ducts, gas pipelines, water pipelines, communications cable, sanitary and



## Utility Identification and Strike Avoidance Standard

storm sewers, hazardous materials pipelines, and associated substructures.

### Implementation Responsibilities

The Environmental Remediation Safety & Compliance Principal is responsible for implementing this standard and associated procedures.

This standard will be communicated to the target audience through PM Orientation training courses and through 5-Minute Meeting tailboards conducted annually in person, or electronically.

### Governing Document

NA

### Compliance Requirement/Regulatory Commitment

[California Government Code Section 4216](#)

[California Business and Professions Code, Section 7110](#)

[Construction Safety Orders: Code of California Regulations \(CCR\), Title 8, Section 1541, Excavations](#)

### Reference Documents

1. [Utility Standard S4412 – Preventing Damage to Underground Facilities](#)
2. [Utility Work Procedure WP4412-01 – Operating Procedures for Locating Instruments](#)
3. [Utility Work Procedure WP4412-02 – Locating Instruments Calibration Verification and Repair Procedures](#)
4. [Utility Work Procedure WP4412-03 – Marking and Locating PG&E Underground Facilities](#)
5. [Utility Work Procedure WP4412-04 – Field Meets and Standby Damage Prevention](#)
6. [Utility Work Procedure WP4412-05 – Excavation Procedures for Damage Prevention](#)
7. [Utility Procedure TD4412P-06, Handling Excavators, Contractors, and the Public Working Unsafely Around Utility Facilities](#)
8. [Utility Procedure TD-4412P-07, Patrolling Pipelines and Mains](#)



## Utility Identification and Strike Avoidance Standard

9. [Utility Procedure TD-4412P-08, Preserving Surface Marks After a Dig-In](#)
10. [Utility Procedure TD-4412P-09, Gas Pipeline Markers](#)
11. [Utility Bulletin TD-2999B-002, Fiber Optic Cable Incident Notification](#)
12. USP 21, Damage Claims Collection
13. [SAFE 1001S, Safety and Health Program](#)
14. [UO Standard D-S0350/S4110, Leak Survey and Repair of Gas Transmission and Distribution Facilities](#)
15. [UO Standard D-S0457, Gas Mapping Standard, 1" = 100' Plat Sheets](#)
16. [UO Standard S0502, Protection of Sensitive Operational Information](#)
17. [SH&C Procedure 103, Public Safety Information Program](#)
18. [SH&C Procedure 104, Observed Hazard Notification: Third Parties Working Around Utility Facilities](#)
19. PG&E Protective Grounding Manual
20. [PG&E Code of Safe Practices](#)
21. PG&E Website – <http://www.pge.com/contractorsafety>

---

**Appendices** NA

---

**Attachments** NA

---

**Document  
Revision** NA

---

**Approved By** Kevin Sullivan, Director, Environmental Remediation

---



## Utility Identification and Strike Avoidance Standard

**Document Owners** Heather Crawford, Principal, Environmental & Safety Compliance,  
Environmental Remediation

---

**Document Contact** Heather Crawford, Principal, Environmental & Safety Compliance,  
Environmental Remediation

---

### Revision Notes

Where?	What Changed?
NA	Updated cited regulatory citation, added Waivers and Exemptions, and added definition of Remote/Greenfield site in addition to minor grammar.
Section 2	Added section to cover exemptions and waivers.

## **APPENDIX M**

### **TCS Excavation Guidance**

TD-4621M, Rev. 1

# Excavation Safety Manual

Gas Operations



*For Reference Use*

Publication Date: July 23, 2014  
Effective Date: January 1, 2015







TD-4621M, Rev. 1  
Excavation Safety Manual  
Copyright ©2014  
Pacific Gas and Electric Company  
All rights reserved

No part of this publication may be reproduced, stored in a retrieval system, or transmitted in any form or by any means, electronic, mechanical, photocopying, recording, or otherwise, without the prior written permission of the Pacific Gas and Electric Company.

For information, address:

Pacific Gas and Electric Company  
Gas Technical Document Management  
GasTDMMail@pge.com

## Document Contact

Gas Methods and Procedures Department, Excavation Safety Standards Engineer  
Use Corrective Action Program (CAP) to improve documents and procedures.  
Notify document contact if you identify an opportunity to improve this procedure.

This excavation safety manual is in compliance with TD-4621S, which fulfills the regulatory requirements for excavation safety of the following regulations:

- Code of Federal Regulations (CFR) Title 29—Labor, Subtitle B—Regulations relating to labor (continued), Chapter XVII—Occupational Safety and Health Administration, Department of Labor (continued), Part 1926—Safety and health regulations for construction, Subpart P, Excavations.
- 29 CFR § 1926.800, Underground construction.
- 29 CFR § 1926.956, Underground lines.
- California Code of Regulations (CCR) Title 8, Sections 1540, “Excavations,” 1541, “General Requirements,” and 1542, “Shafts.”



# Preface

## Excavation Safety

Excavating is recognized as one of the most hazardous construction operations. Prevention of trench wall cave-in and soil movement is a primary worker safety precaution in underground construction activities. Serious injury or death can occur to crew members if appropriate measures are not taken. The key components of excavation safety are responsibility and compliance.

### Responsibility

Shoring vendors provide shoring materials and technical (tabulated or tab) data. Vendors often recommend shoring systems for particular applications in the field. The vendor's recommendations do not relieve the Competent Person, a Pacific Gas and Electric Company (Company) employee, of sole accountability and responsibility for selecting and properly installing appropriate excavation safety systems.

The Company Competent Person is always responsible and accountable for excavation safety.

### Compliance

The contents of this manual are based on a thorough analysis of soil by registered Professional Engineers (P.E.). The manual includes specific safety information and requirements for working in different soil types. When used with the other Company safety rules and requirements for the workplace, information contained in this manual meets or exceeds state and federal safety requirements.

THIS PAGE INTENTIONALLY  
LEFT BLANK



# Table of Contents

*This Table of Contents lists parts, sections, and key subsections.*

Preface .....i  
Table of Contents ..... iii

## Part 1: Introduction ..... 1-1

1. About this manual ..... 1-1  
2. Key contacts ..... 1-2  
    2.1 Contact numbers during business hours ..... 1-2  
    2.2 Contact numbers during nonbusiness hours ..... 1-2  
3. Content certification ..... 1-3  
4. Definitions ..... 1-4

## Part 2: Planning for Safety ..... 2-1

1. Determining need for shoring, sloping, shielding or  
benching..... 2-1  
    1.1 Competent Person ..... 2-1  
    1.2 Is shoring, benching, shielding or sloping  
    necessary? ..... 2-3  
2. Classifying the soil ..... 2-5  
    2.1 Soil classifications..... 2-5  
    2.2 Classification test methods ..... 2-7  
    2.3 Determine soil classification..... 2-9  
3. Availability of materials..... 2-10  
4. Work outside scope of manual..... 2-10  
5. Special excavation conditions..... 2-10  
    5.1 Very soft clay ..... 2-10  
    5.2 Saturated sand..... 2-10  
    5.3 Peaty soil ..... 2-11  
    5.4 Rubble rock or rock fill ..... 2-11  
    5.5 Sloping ground..... 2-11  
    5.6 Adjacent slopes..... 2-12  
    5.7 Sloping subsurface layers..... 2-13  
    5.8 Working near structures or heavy machinery ..... 2-14

## Part 3: Working Safely..... 3-1

1. Excavating .....	3-1
1.1 Digging with power equipment .....	3-1
1.2 Spoil placement .....	3-1
<i>Temporary spoil</i> .....	3-1
<i>Permanent spoil</i> .....	3-2
<i>Unusual conditions</i> .....	3-3
<i>Contaminated soil</i> .....	3-3
1.3 Remove hazardous conditions .....	3-4
1.4 Excavating near electric utility structures .....	3-4
2. Preparing to enter an excavation .....	3-5
2.1 Hazards associated with shoring and working in excavations .....	3-5
<i>Hazardous atmospheres</i> .....	3-5
<i>Confined space</i> .....	3-6
<i>Safety around hydraulic shoring fluid</i> .....	3-6
<i>Safety at heights</i> .....	3-6
<i>Changes in environment or jobsite conditions</i> .....	3-7
<i>Hazards associated with water accumulation</i> .....	3-7
<i>Getting into and out of the excavation</i> .....	3-8
2.2 Installing protective systems .....	3-9
3. Zone of shoring .....	3-10
3.1 Side walls .....	3-10
3.2 Trench ends .....	3-11
4. Maintaining safety in the excavation .....	3-12
4.1 Inspections .....	3-12
4.2 Public crossings .....	3-13
4.3 Jobsite access and traffic control .....	3-13

## Part 4: Protective Systems: Shores and Shields ..... 4-1

1. About protective systems .....	4-1
1.1 Installing shoring .....	4-1
1.2 Removing shoring .....	4-1
2. Hydraulic shoring .....	4-2
2.1 Advantages .....	4-2
2.2 Removing the pins from hydraulic shoring .....	4-2
2.3 Installation requirements .....	4-4
3. Trench shields, boxes or cages .....	4-7
4. Protective systems: typical installations .....	4-10
4.1 Shoring bell hole with perpendicular corners .....	4-10
4.2 Protecting a T intersection .....	4-10
4.3 Shoring around a box .....	4-11

**Part 5: Sloping and Benching .....5-1**

- 1. Sloping excavation walls..... 5-1
  - 1.1 Why slope? ..... 5-1
  - 1.2 Profile of simple slope ..... 5-1
- 2. Sloping and vertical wall combinations ..... 5-2
  - 2.1 Sloping with short vertical walls ..... 5-3
- 3. Benching an excavation..... 5-3

**Part 6: Cave-In Emergency Plan .....6-1**

- 1. Elements of the cave-in emergency plan..... 6-1
  - 1.1 Emergency notification..... 6-1
  - 1.2 Supporting an emergency rescue ..... 6-2
  - 1.3 Stabilizing and entering the excavation ..... 6-3
  - 1.4 Caring for a victim ..... 6-4
  - 1.5 Moving a victim ..... 6-4
- 2. Cave-in emergency checklist..... 6-4
  - 2.1 Call for rescue service ..... 6-4
  - 2.2 Notify Company supervision ..... 6-5
  - 2.3 Crew foreman or Competent Person’s duties ..... 6-5
  - 2.4 Prepare site for emergency response..... 6-5
  - 2.5 Identify hazards..... 6-6
  - 2.6 Caring for a victim ..... 6-7

**Part 7: Type A Soil .....7-1**

- 1. Characteristics ..... 7-1
- 2. Hydraulic shoring data ..... 7-2
  - 2.1 Spacing components ..... 7-2
- 3. Shoring examples ..... 7-3
  - 3.1 Other applications ..... 7-3
- 4. Sloping ..... 7-4
  - 4.1 Supported or shielded sloping ..... 7-6
  - 4.2 Unsupported vertical lower walls ..... 7-6
- 5. Benching ..... 7-9
  - 5.1 Single bench ..... 7-9
  - 5.2 Multiple benches ..... 7-10

**Part 8: Type B Soil .....8-1**

- 1. Characteristics .....8-1
- 2. Hydraulic shoring .....8-1
  - 2.1 Spacing combinations .....8-1
- 3. Shoring examples .....8-3
  - 3.1 Other applications .....8-3
- 4. Waler systems .....8-4
- 5. Sloping .....8-6
  - 5.1 Slope profile .....8-6
  - 5.2 Supported or shielded sloping .....8-8
- 6. Benching .....8-9
  - 6.1 Single bench .....8-9
  - 6.2 Multiple benches .....8-9

**Part 9: Type C Soil .....9-1**

- 1. Characteristics .....9-1
- 2. Hydraulic shoring data .....9-2
  - 2.1 Requirements .....9-2
- 3. Waler systems .....9-3
  - 3.1 Other applications .....9-4
- 4. Sloping .....9-4
  - 4.1 Profile of slope .....9-4
  - 4.2 Supported or shielded sloping .....9-6

**Part 10: Sloping Layered Soil .....10-1**

- 1. About sloping layered soil .....10-1
  - 1.1 Layered soil: Type A over Type B .....10-2
  - 1.2 Layered soil: Type A over Type C .....10-3
  - 1.3 Layered soil: Type B over Type A .....10-4
  - 1.4 Layered soil: Type B over Type C .....10-5
  - 1.5 Layered soil: Type C over Type A .....10-6
  - 1.6 Layered soil: Type C over Type B .....10-7

**Part 11: Frequently Asked Questions..... 11-1**

1. Resource information.....	11-1
2. Creating the excavation .....	11-3
3. Competent Person .....	11-4
4. Soils and soil classification .....	11-5
5. Benching and sloping.....	11-6
6. Shoring and protective systems.....	11-6
6.1 What to use and when .....	11-6
6.2 Sheeting .....	11-9
6.3 Installation .....	11-9
6.4 Shoring maintenance .....	11-11
7. Excavation security .....	11-12
8. Cal/OSHA.....	11-12
9. Controlling hazards .....	11-13

**Appendices****Appendix A: Soil Mechanics ..... A-1**

1. Earth pressures.....	A-1
2. Trench stress and failure .....	A-3
3. The cave-in process.....	A-6

**Appendix B: Foreman’s Guide for Briefing  
Cal/OSHA Inspectors ..... B-1**

1. What to do.....	B-1
2. Inspector checklist .....	B-2

**Appendix C: Acceptable Bridges and  
Guardrails for Public Crossing of  
Excavations ..... C-1**

1. Walkway.....	C-1
2. Toeboards .....	C-1
3. Guardrails.....	C-1



**Appendix D: Third-Party Protected  
Excavations..... D-1**

- 1. Ensuring worker safety..... D-1
- 2. Verifying tabulated data..... D-2
- 3. Checklist..... D-5

**Appendix E: Effects of Water and Remedies. E-1**

- 1. Effects of water..... E-1
- 2. Dewatering ..... E-1

**Appendix F: References and Related  
Resources .....F-1**



# Part 1

## Introduction

### 1

## About this manual

TD-4621M, the Excavation Safety Manual, has been updated, reformatted, and renumbered from the 2006 version. The form of the manual is smaller and sturdier for more practical use in the field. New content integrates end-user feedback, best practices, and improved compliance with the following regulations:

- Code of Federal Regulations (CFR) Title 29—Labor, Subtitle B—Regulations relating to labor (continued), Chapter XVII—Occupational Safety and Health Administration, Department of Labor (continued), Part 1926—Safety and health regulations for construction, Subpart P, Excavations.
- 29 CFR § 1926.800, Underground construction.
- 29 CFR § 1926.956, Underground lines.
- California Code of Regulations (CCR) Title 8, Sections 1540, “Excavations,” 1541, “General Requirements,” and 1542, “Shafts.”

This manual, in its entirety, must be kept at every jobsite where excavations are being performed.

### 1.1 Scope

This manual explains what employees must do to safely evaluate excavations and to use a cave-in prevention system. This manual describes how to properly protect that excavation from caving in.

Any employees using a cave-in prevention system not covered by the manual must consult a registered Professional Engineer (P.E.) for assistance. See Part 2, Section 5, for a list of special excavation conditions that also require consultation with a registered P.E.

### 1.2 Excavation plans

This manual plus any manufacturer’s tabulated data for cave-in prevention systems on the job site make up the excavation plan. According to regulations enforced by the California Division of Occupational Safety and Health (Cal/OSHA), such an excavation plan must be kept at every excavation job site.

## 2

## Key contacts

### 2.1 Contact numbers during business hours

**Table 1-1. Contact numbers during business hours**

CONTACT REASON	CONTACT NUMBER
<b>Report incident, accident, or injury</b>	Safety Department Helpline (415) 973-8700
<b>Request cave-in rescue</b>	<b>Dial 911 for emergency rescue</b>
Engineering, soil analysis, and special cases	PG&E Geosciences (415) 973-5291
Report a Cal/OSHA <b>investigation</b> at the jobsite <b>Note:</b> Notify the supervisor. The supervisor must contact the Company Legal Department. See Appendix B, "Foreman's Guide for Briefing Cal/OSHA a Cal/OSHA investigation.	Safety Department Helpline (415) 973-8700
Report a Cal/OSHA <b>inspection</b> at the jobsite <b>Note:</b> See Appendix B for procedures to use during a Cal/OSHA inspection.	Safety Department Helpline (415) 973-8700
Safety issues or questions	Safety, Health and Claims Helpline (415) 973-8700

### 2.2 Contact numbers during non-business hours

**Table 1-2. Contact numbers during non-business hours**

CONTACT REASON	CONTACT NUMBER
<b>Report incident, accident, or injury</b>	Safety Department Helpline (415) 973-8700
<b>Request cave-in rescue</b>	<b>Dial 911 for emergency rescue</b>
Safety issues requiring immediate attention	Safety Department Helpline (415) 973-8700

## 3

## Content certification

I hereby certify that this manual meets the requirements of California Code of Regulations (CCR) Title 8, Industrial Relations, Division 1, Department of Industrial Relations, Chapter 4, Division of Industrial Safety, Subchapter 4, Construction Safety Orders, Article 6, Excavations, § 1540, "Excavations."

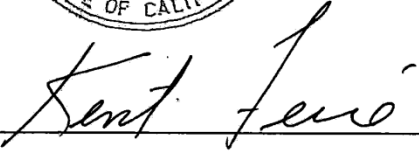

A handwritten signature in cursive script that reads "Kent Ferre". The signature is written over a horizontal line.

Kent Ferre, S. E.

Manager

California Registration Number 3122

Date 3/14/2014

## 4

## Definitions

Definitions marked with an asterisk (\*) are quoted directly from the the California Code of Regulations (CCR), Title 8, Section 1540, (b) Definition of terms for excavations, or 8 CCR § 1541.1, Appendix A, (b) Definition of terms for soil classifications.

**\*Accepted engineering practices:** Requirements which are compatible with the standards of practice required of a registered professional engineer.

**Access and egress:** Entry and exit, respectively. In trenching and excavation operations, these terms refer to the provision of safe means for employees to enter or exit an excavation or trench.

**Adjacent structures stability:** The stability of the foundation(s) of structures adjacent to the excavation, whose location may create surcharges, changes in soil conditions, or other disruptions that have the potential to extend into the failure zone of the excavation or trench.

**\*Aluminum hydraulic shoring:** A pre engineered shoring system comprised of aluminum hydraulic cylinders (cross braces) used in conjunction with vertical rails (uprights) or horizontal rails (walers). This system is designed specifically to support the side walls of an excavation to prevent cave-ins.

**\*Benching (benching system):** A method of protecting employees from cave-ins by excavating the sides of an excavation to form one or a series of horizontal levels or steps, usually with vertical or near-vertical surfaces between levels.

**CCR:** California Code of Regulations. The citations in this manual can be found on <http://www.dir.ca.gov/Title8/1540.html>.

**Caliche:** A silt or sand that is cemented with calcium carbonate. The calcium carbonate is deposited by the evaporation of ground water brought to the ground surface by capillary action.

**Cal/OSHA:** California Division of Occupational Safety and Health.

**Caution:** Information about an operating procedure, technique, etc., which could result in damage to equipment or interruption of service to customers if not carefully followed.

**\*Cave-in:** The separation of a mass of soil or rock material from the side of an excavation, or the loss of soil from under a trench shield or support system, and its sudden movement into the excavation, either by falling or sliding, in sufficient quantity so that it could entrap, bury, or otherwise injure or immobilize a person.

**\*Cohesive soil:** Clay (fine grained soil), or soil with a high clay content, which has cohesive strength. Cohesive soil does not crumble, can be excavated with vertical side slopes, and is plastic when moist. Cohesive soil is hard to break up when dry, and exhibits significant cohesion when submerged. Cohesive soils include clayey silt, sandy clay, silty clay, clay and organic clay.

**NOTE**

Competent Person is defined in  
CCR Title 8, Subchapter 4, §1504 (a).

**\*Competent Person:** Person who is capable of identifying existing and predictable hazards in the surroundings or working conditions which are unsanitary, hazardous, or dangerous to employees, and who has authorization to take prompt, corrective measures to eliminate them.

**Confined space:** A space that, by design and/or configuration, has limited openings for entry and exit and unfavorable natural ventilation, may contain or produce hazardous substances, and is not intended for continuous employee occupancy.

**\*Cross braces:** The horizontal members of a shoring system that are installed perpendicular to the sides of the excavation the ends of which bear against either the uprights or the wales.

**Egress:** See *Access and egress*.

**Employee crossing:** See *Safe crossing*.

**\*Excavation:** Any man-made cut, cavity, trench, or depression in an earth surface, formed by earth removal.

**Excavation safety system:** See *Protective system*.

**\*Faces (sides):** The vertical or inclined earth surfaces formed as a result of excavation work.

**\*Failure:** The breakage, displacement, or permanent deformation of a structural member or connection so as to reduce its structural integrity and its supportive capabilities.

**Fed/OSHA (OSHA):** United States Department of Labor Occupational Safety and Health Administration.

**\*Fissured:** A soil material that has a tendency to break along definite planes of fracture with little resistance, or a material that exhibits open cracks, such as tension cracks, in an exposed surface.

**H:V:** Ratio of horizontal to vertical or run to rise.

**Hazardous Atmosphere:** An atmosphere which by reason of being explosive, flammable, poisonous, corrosive, oxidizing, irritating, oxygen deficient, toxic, or otherwise harmful, may cause death, illness, or injury. This includes atmospheres with an oxygen content of less than 19.5% or greater than 23.5%, and/or containing gas levels greater than 1% gas in air.

**\*Kickout:** The accidental release or failure of a cross brace.

**Loam:** A mixture of clay, sand, and silt. The stability of loam depends on the moisture content and the proportions of each of the components. Loams are often named by their major component, so a sandy loam has a large sand component, a clay loam has a large clay component, etc.

**\*Layered system:** Two or more distinctly different soil or rock types arranged in layers. Micaceous seams or weakened planes in rock or shale are considered layered. Layered soil systems are classified on the basis of the weakest soil layer.

**Nominal thickness of wood products:** Nominal thickness is a term for the unfinished or unplanned dimensions of the wood before final finishing. For example, although a two-by-four has a nominal thickness of 2" x 4", the material normally used actually measures approximately 1½" x 3½".

**Qualified worker:** Any worker who has some special skill, knowledge, or (usually acquired) ability in their work.

**Previously disturbed soil:** Soil moved from its native (original) location. Example: dug and backfilled excavations and fill locations.

**\*Protective system:** A method of protecting employees from cave-ins, from material that could fall or roll from an excavation face or into an excavation, or from the collapse of adjacent structures. Protective systems include support systems, sloping and benching systems, shield systems, and other systems that provide necessary protection.

**Public crossing:** A location where the public crosses trenches or other excavations.

**\*Ramp:** An inclined walking or working surface that is used to gain access to one point from another, and is constructed from earth or from structural materials such as steel or wood.

**NOTE**

To consult with a registered Professional Engineer (P.E.), contact the Geosciences department or a shoring vendor.

**\*Registered professional engineer:** A person who is registered as a professional engineer in the state where the work is to be performed. However, a professional engineer registered in any state is deemed to be a “registered professional engineer” within the meaning of this standard when approving designs for “manufactured protective systems” or “tabulated data” used in interstate commerce.

**Safe crossing:** A secured wood walkway built with 2"-thick planks, 1 $\frac{1}{8}$ "-thick plywood, or a material of equivalent strength that is at least 24" wide.

**\*Sheeting:** The members of a shoring system that hold the earth in position and in turn are supported by other members of the system.

**\*Shield (shield system):** A structure that is able to withstand the forces imposed on it by a cave-in and thereby protects employees within the structure. Shields can be permanent structures or can be designed to be portable and moved along as work progresses. Additionally, shields can be either pre-manufactured or built on the job.

**\*Shoring (shoring system):** A structure such as a metal hydraulic, mechanical, or timber shoring system that supports the sides of an excavation and which is designed to prevent cave-ins.

**\*Sides:** See *Faces*.

**Slide rail shoring system:** A modular shoring system installed to the required depth in successive steps. The system consists of interlocking panels and posts installed by backhoe or excavator. The system is assembled at the surface from a pilot hole. It is subsequently deepened by digging inside the slide rail system, pushing the slide rail system down and adding more panels to deepen the shoring system.

**\*Sloping (Sloping system):** A method of protecting employees from cave-ins by excavating to form sides of an excavation that are inclined away from the excavation to prevent cave-ins. The angle of incline required to prevent a cave-in varies with differences in such factors as the soil type, environmental conditions of exposure, and application of surcharge loads.

**Special case:** Any situation not specifically described in this manual.

**Spoil:** The material (e.g., rocks and soil) removed from an excavation.



**NOTE**

The Company requires that rock be solid and unfractured to be considered stable rock. Rock that is fractured, cracked, splintered or otherwise broken is not stable rock.

**\*Stable rock:** Natural solid mineral material that can be excavated with vertical sides and will remain intact while exposed. Unstable rock is considered to be stable when the rock material on the side or sides of the excavation is secured against caving-in or movement by rock bolts or by another protective system that has been designed by a registered professional engineer.

**\*Structural ramp:** A ramp built of steel or wood, usually used for vehicle access. Ramps made of soil or rock are not considered structural ramps.

**Superimposed loads:** Any item or material that exerts additional forces on the soil in the area of the excavation (e.g., the spoil pile or equipment placed close to the edge of the excavation). See also *Surcharge*.

**\*Support system:** A structure such as underpinning, bracing, or shoring that provides support to an adjacent structure, underground installation, or the sides of an excavation.

**Surcharge:** Excessive vertical load or weight caused by spoil, overburden, vehicles, equipment, or activities that may affect trench stability. See also *Superimposed loads*.

**\*Tabulated data:** Tables and charts approved by a registered professional engineer and used to design and construct a protective system.

**\*Trench (trench excavation):** A narrow excavation (in relation to its length) made below the surface of the ground. In general, the depth is greater than the width, but the width of the trench (measured at the bottom) is not greater than 15 feet. If forms or other structures are installed or constructed in an excavation so as to reduce the dimension measured from the forms or structure to the side of the excavation to 15 feet or less (measured at the bottom of the excavation), the excavation is also considered to be a trench.

**\*Trench box.** See *Shield*.

**\*Trench shield.** See *Shield*.

**Type A soil:** See Part 2, Section 2, and Table 2-1 for a description of Type A soil.

**Type B soil:** See Part 2, Section 2, and Table 2-1 for a description of Type B soil.

**Type C soil:** See Part 2, Section 2, and Table 2-1 for a description of Type C soil.

**Underpinning:** A method of providing support underneath an undermined structure.

**Underground installations:** Include, but are not limited to, utilities (sewer, telephone, fuel, electric, water, and other product lines), tunnels, shafts, vaults, foundations, and other underground fixtures or equipment that may be encountered during excavation or trenching work.

**Unconfined compressive strength:** The load per unit area at which soil will fail in compression. This measure can be determined by laboratory testing, or it can be estimated in the field using a pocket penetrometer, thumb penetration tests, or other methods.

**\*Uprights:** The vertical members of a trench shoring system that are placed in contact with the earth and are usually positioned so that individual members do not contact each other. Uprights placed so that individual members are closely spaced, in contact with, or interconnected to each other are often called "sheeting."

**\*Wales:** Horizontal members of a shoring system placed parallel to the excavation face whose sides bear against the vertical members of the shoring system or the earth.

**Warning:** Information about an operating procedure, technique, etc., that could result in personal injury or loss of life if not carefully followed.

**Zone of shoring:** The area within an excavation where employees are protected from the danger of cave-in. See Part 3, Section 3 for more information.

THIS PAGE INTENTIONALLY  
LEFT BLANK



## Part 2

# Planning for Safety

The crew leader and Competent Person must plan each excavation to protect crew members and other workers from multiple hazards. To ensure safety, the Competent Person must decide:

1. Whether shoring, benching, or sloping is required.
2. What the soil type is.
3. Whether any special hazards are present that require the consultation of a registered Professional Engineer (P.E.) (Geosciences or a shoring vendor).
4. What cave-in prevention system will be used.

This part describes the process of evaluating and planning an excavation for safety.

1

## Determining need for shoring, shielding, sloping, or benching

### CAUTION

Damage to underground facilities may occur if excavations are performed without a current USA ticket. USA tickets are **REQUIRED** and valid for 28 days from the date issued.

### 1.1 Competent Person

A Competent Person must be on site at all times personnel are in the excavation to ensure that conditions have not changed and created a hazard for personnel.

To be a Competent Person, one must satisfy the criteria in Table 2-1 on page 2-2.

**Table 2-1. Competency requirements**

EITHER	OR
Successful completion of a Company-approved course in excavation safety training for the Competent Person	Pass an approved Competent Person certification examination
AND	
<ul style="list-style-type: none"> <li>▪ Be designated as the Competent Person, <b>and</b></li> <li>▪ Demonstrate ability to appropriately classify soil and select protective systems</li> </ul>	

Source: TD-4621S, Attachment 1, "Excavation Safety Guide."

#### The Competent Person:

- Evaluates all environmental conditions.
- Identifies on-site hazards requiring a registered P.E. or stamped tabulated data.
- Selects the appropriate type of worker protection.
- Inspects the excavation at the beginning of each shift and any time conditions change.

The Competent Person may choose from several protective options, as needed:

- Sloping or benching according to allowable configurations.
- Using a registered P.E. to design a sloping, benching, shielding, or shoring system.
- Using support systems in accordance with this manual or tabulated data.
- Purchasing or renting an engineered protective system (e.g., trench box, shield, cage).

The types of protection selected for the excavation depend on several factors, including:

- Size and shape of excavation.
- Type of soil.
- Availability of materials.
- Length of time excavation needs to be secured.

## 1.2 Is shoring, benching, shielding, or sloping necessary?

Unless specified by a registered P.E. or stamped tabulated data, existing unshored subsurface walls or structures are **not** acceptable means to ensure safety.

As with an unprotected trench end, any excavation into a hill or bank resulting in a 5' or greater wall must be sloped or benched, or personnel must remain back a distance equal to the height with a barrier (visual or physical) present.

A cave-in prevention system is always required if any of the following conditions exist:

- The sides of the excavation are unstable and the work cannot be performed safely.
- The excavation is at least 5' deep at any point and someone will enter the excavation.

Use the following flow chart to determine whether cave-in protection (sloping, benching, shoring, or a box/shield) is required.

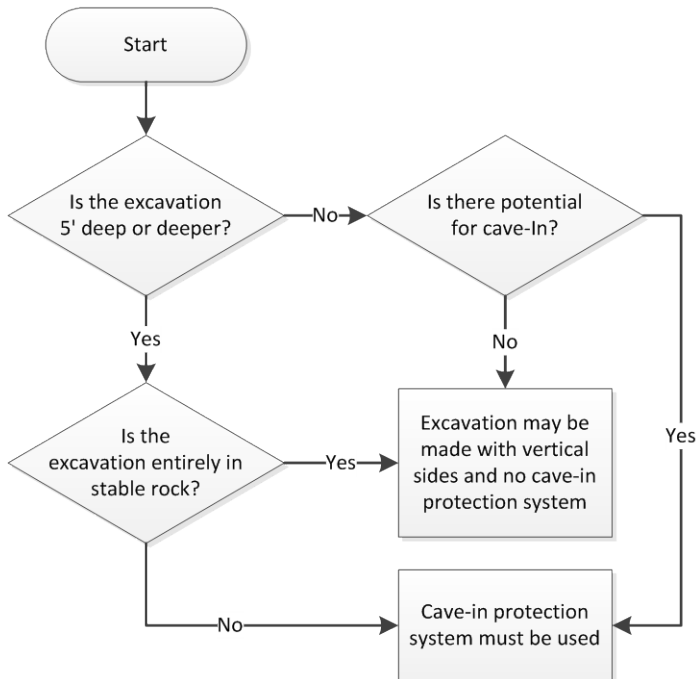

**Figure 2-1. Excavation safety decision process**

## Pre-construction meetings

Excavation Safety should be a topic of conversation at all pre-construction meetings. Conversation should cover the following areas.

1. Verifying that essential permits were obtained.
2. Discussing the Excavation Plan.
3. Discussing the Cave-In Emergency Plan.
4. Resolving schedules.
5. Verifying USA Ticket.
6. Scheduling required inspections.
7. Verifying that essential variances from local codes or ordinances were obtained.

## Permitting

The Company is exempt from obtaining a Cal/OSHA excavation permit before starting excavation work. However, other government agencies (counties, cities, municipalities, etc.) may require various permits before the Company begins earthwork activities. These local regulations may require the Company to contact the appropriate local authority to determine its permit requirements as far in advance of the anticipated start date as practical. Ensure that all needed permits are issued before work begins.

## Bell holes

Provide employees with adequate room to work in the bell hole. Use the same protective measures in bell holes that are required for all other excavations.

## 2

## Classifying the soil

### 2.1 Soil classifications

#### WARNING

Low-strength Type C Soil is a special case and always requires either assistance from a registered P.E. or the use of stamped tabulated data **before** excavating. See Part 1, Section 1.2 for phone numbers.

There are 5 main types of soil:

- **Rock:** Rock is the most stable type of soil. **Never** assume the soil is rock and **always** assume there are fissures in any rock.
- **Cemented soil:** This is soil that has constituents of rock (such as limestone) dissolved and bound into the soil, making it harder.
- **Cohesive soils:** These are typically clays which bind together, but not as strongly as cemented soils.
- **Granular soils:** The size of the aggregates defines whether this soil is gravel, sand or silt.
- **Loams:** Loams are mixtures of sand, silt, and clay. Their stability depends on the proportions of the three and the moisture.

For more information on soil mechanics, see Appendix A, "Soil Mechanics."

#### Classification for excavation

To classify soil for excavations, the Company uses the soil classification system outlined in Table 2-2 on page 2-6.



**Table 2-2. Soil classification system**

TYPE	CHARACTERISTICS
Stable Rock	Natural solid mineral matter which can be excavated with vertical sides and remain intact while exposed.
A	<p>Cohesive with an unconfined compressive strength of 1.5 tons per square foot (TSF) or greater. Can be:</p> <ul style="list-style-type: none"> <li>• Clay</li> <li>• Silty clay</li> <li>• Sandy clay</li> <li>• Clay loam</li> <li>• Cemented soil</li> </ul> <p>Soil CANNOT be classified as Type A if ANY destabilizing factors are present, such as:</p> <ul style="list-style-type: none"> <li>• Soil is fissured</li> <li>• Vibrations have been or may be present</li> <li>• Soil has been previously disturbed</li> <li>• Soil is sloped or layered on a slope of 4:1 H:V or steeper. See Figure 2-4 for more information.</li> </ul> <p>Other factors may also bar soil from classification as Type A.</p>
B	<p>Cohesive with an unconfined compressive strength greater than 0.5 TSF but less than 1.5 TSF. Examples of Type B soil are:</p> <ul style="list-style-type: none"> <li>• Granular cohesionless soil (crushed rock, silt loam, sandy clay loam)</li> <li>• Previously disturbed soil not classified as type C</li> <li>• Type A soil that is fissured or subject to vibration</li> <li>• Dry rock that is not stable</li> </ul>
C	<p>Cohesive soil with an unconfined compressive strength of 0.5 TSF or less. Examples of Type C are:</p> <ul style="list-style-type: none"> <li>• Granular soil</li> <li>• Submerged rock that is not stable</li> <li>• Moist cohesive or moist dense granular</li> <li>• Soil that can be cut near-vertical and stand long enough to allow shoring and sheeting to be properly installed</li> <li>• NOT flowing or submerged</li> </ul>
Low-strength C	<p>These soils require assistance from a registered P.E. Examples of low-strength C are:</p> <ul style="list-style-type: none"> <li>• Granular soil including gravel, sand</li> <li>• Submerged soil</li> <li>• Soil from which water is freely seeping</li> <li>• Soils not meeting the classifications outlined above</li> <li>• Anywhere water is present</li> </ul> <p>Vendors may refer to low-strength C as "C-80."</p>

## 2.2 Classification test methods

A **minimum of two** soil classification tests (one visual and one manual) must be performed by the Competent Person. Soil reports prepared by an engineer are helpful, but the Competent Person is responsible for testing and classifying the soil in the excavation.

### WARNING

Do not enter an unprotected excavation to collect samples or conduct soil tests. Use fresh samples removed from the excavation.

### Visual tests

A visual test is a qualitative evaluation of soil conditions in the entire excavation site, including soil adjacent to the site and soil being excavated. Visual tests are listed below.

#### ***Soil grain size***

- If you see individual grains **and** few clumps, which are easily crushed, soil is granular.
- If individual grains are **not** visible and the soil stays in clumps when excavated, the soil is cohesive.

#### ***Checking the trench sides***

- Cracks or chunks of soil spalling from a vertical wall indicate fissured ground and a potentially hazardous situation.
- If soil is layered, review the slope by comparing the depth on one side of the trench to the layer depth on the alternate side. See Part 2, Section 5.7 for more details.

#### ***Checking the area for previous disturbance***

- Clear ground vegetation to look for cracks in the soil around the excavation.
- Look for evidence (811 markings or other surface indicators) of existing underground or aboveground infrastructure which indicate the ground had been previously disturbed.

#### ***Checking for water***

- Trench side bulging, boiling, sloughing or water seeping from trench sides from the groundwater table classify the soil as low-strength Type C. Contact a registered P.E.

## Manual tests

A manual test is a manual analysis of soil sample conducted to provide more information to enable proper classification of the soil. After the visual test, at least one manual test is required to classify the soil. Examples of manual tests follow.

### ***Plasticity test***

Soil is cohesive if a fresh, moist, or wet soil sample can be rolled into threads  $\frac{1}{8}$ " in diameter approximately 2" long without crumbling.

### ***Drying test***

Thoroughly dry a sample of soil approximately 1" thick by 6" in diameter and assess according to Table 2-3, below.

**Table 2-3. Drying test**

IF...		THEN THE SAMPLE...
Sample develops cracks as it dries.		Has significant fissures.
Considerable hand force is required to break samples that dry without cracking.		Is unfissured cohesive material. The unconfined compressive strength should be determined.
Samples are dry without cracking, and break easily by hand.	Dried clumps pulverize easily by hand.	Is fissured cohesive.
	Dried clumps pulverize into very small fragments.	Is granular.
Soil is dry and crumbles on its own or with moderate pressure into individual grains or fine powder.		Is granular (any combination of gravel, sand, or silt).
Soil is dry and falls into clumps which break up into smaller clumps, but the smaller clumps can only be broken up with difficulty.		May be clay in any combination with gravel, sand or silt and is cohesive.
Dry soil breaks into clumps which do not break up into small clumps and which can only be broken with difficulty, and there is no visual indication the soil is fissured.		Is unfissured.

**Thumb penetration test**

Conduct the thumb test on an undisturbed soil sample, such as a large clump of spoil, as soon as practicable after excavation to limit the drying effects of exposure. See Table 2-4, below.

**Table 2-4. Thumb test**

TYPE	THUMB TEST RESULTS
A	Sample can be indented by the thumbnail readily, but penetrated only with very great effort, <b>and</b> the soil is very fine grained.
B	The thumb can penetrate with moderate effort.
C	Soil is easily penetrated several inches by the thumb, and can be molded by light finger pressure.
Low-strength C	Soil is easily penetrated several inches by the fist.

**Other strength tests**

Estimate the unconfined compressive strength using a pocket penetrometer or hand-operated shear vane.

## 2.3 Determine soil classification

When making the final soil classification, consider all of the following factors.

- What are the properties of the soil in the excavation?
- How does the soil perform now?
- What will happen to the soil over time once the excavation is opened (e.g., when the soil either dries out or gets wet)?
- Do environmental conditions reduce the stability of the sides of the excavation?

Remember:

- For layered soil, base the soil classification on the weakest layer.
- Consider only current conditions.
- When conditions change, re-evaluate the soil for possible reclassification.
- To determine soil type, use the soil classification chart in the tri-fold guide in the back pocket of this manual (TD-4621S, Attachment 1, "Excavation Safety Guide").

## 3

## Availability of materials

For each excavation, plan ahead so that shoring materials are available on time. Wooden shoring components, whether plywood or FinnForm composite material, may require a special order by the lumber supplier to meet special strength requirements (described in Table 4-2 on page 4-5). Metal shoring systems may also require extended delivery time. Identify construction needs as far in advance as possible and place orders early.

## 4

## Work outside scope of manual

Consult with a registered P.E. or use stamped tabulated data for:

- A hydraulic shoring or shielding system deeper than 15'.
- A sloping or benching system deeper than 20'.
- Any method not described in this manual (e.g., tunneling, undermining, or other special case).

## 5

## Special excavation conditions

Employees may encounter soil or site conditions that differ from the scope of this manual. These are special cases that are so variable they must be handled individually. All of the cases in this section require consultation with a registered P.E. or use of stamped tabulated data.

### 5.1 Very soft clay

Very soft clay, such as the soft mud found in the San Francisco Bay Area, may require the use of sheet piles. Engineering evaluations may be required to determine how deep to drive the piles, or for other special construction requirements.

### 5.2 Saturated sand

When the water table is higher than the proposed depth of the excavation, saturated clean or silty sand may be susceptible to a special type of failure known as “quicksand” or “piping.” These failures may occur if water flows upward when using sheet piles, or around existing utilities and underground structures if the groundwater level is high.

When saturated soil is excavated below groundwater level, the water can flow into the excavation around an embedded sheet pile or underground structures. Depending on the difference between the level of the groundwater surface and the depth of the excavation, unstable conditions (quicksand and piping) may develop quickly.

## 5.3 Peaty soil

Peaty or organic soil is made of organic matter in the form of partly decomposed vegetation. Peaty soil is dark gray or black, and usually has a characteristic odor of decay. This material is generally very lightweight, has very low shear strength, and deforms quickly. In Northern California, employees are likely to find peaty soil in river deltas.

## 5.4 Rubble rock or rock fill

Rubble rock and rock fill pose a threat to safe excavation because of large particles or obstructions. However, these field conditions do not automatically rule out the use of benching or shoring. Careful exploration is required to accurately define the nature and extent of the rubble.

## 5.5 Sloping ground

The designs in this manual assume that the excavation will take place on relatively flat ground. If the slope is less steep than 3:1 H:V, as shown in Figure 2-2 on page 2-12, use the procedures in this manual.

### WARNING

When using a support system on a slope, make sure it can withstand the force at the bottom of the deepest side of the excavation.

If the high side of a trench is less than 5' high **and** the soil is stable, shoring is generally not required. Shoring is required if any of the following conditions exist:

- Obvious danger of landslide.
- Uphill slope of 3:1 H:V or steeper.
- Cracks in the soil.
- Other indications of unstable soil.

### NOTE

Always measure the excavation's depth at the deepest point (high side if on a slope).

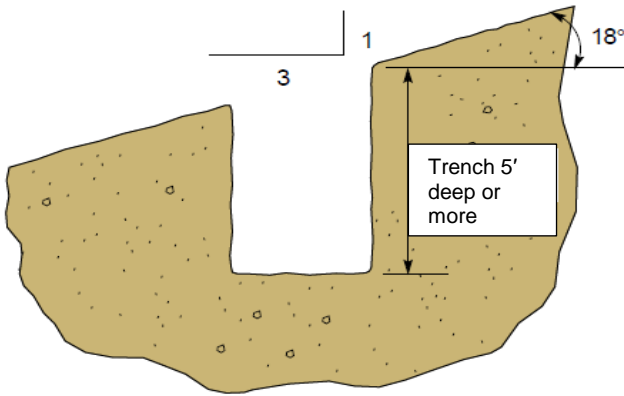

**Figure 2-2. Maximum allowable slope for a standard excavation**

## 5.6 Adjacent slopes

A slope or embankment close to an excavation can impose high loads on the sidewall of the excavation similar to those of a large adjacent structure.

Under either of the following conditions, **before** excavating, get help from a registered P.E. See Figure 2-3, below.

- The toe (base) of a slope of 3:1 H:V or steeper is closer to the excavation than the proposed depth of the excavation.
- The toe of a slope shallower than 3:1 H:V is located closer to the excavation than half the proposed excavation depth AND the proposed depth is greater than 10'.

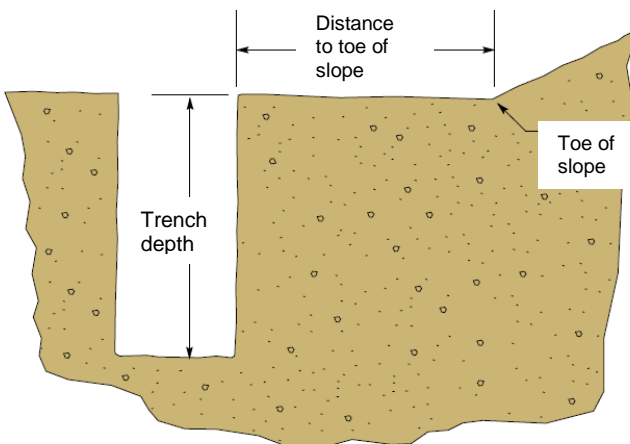

**Figure 2-3. Excavation near an embankment**

## 5.7 Sloping subsurface layers

In some excavations, the soil consists of layers of various types, marked by changes in color, texture, or composition. Where the layers meet, the soil is more likely to slide, creating a potential hazard. Test each soil type to determine its classification. If layers of the soil meet in a slope steeper than 4:1 H:V, increase the shoring requirements to the weaker soil classification.

To determine the slope of a layered system:

1. Measure the height at which the layers change on the right trench wall.
2. Measure the height at which the layers change on the left trench wall.
3. Find the difference in those heights between the right side and the left side.
4. Divide the difference by the trench width.

### **Example:**

As shown in Figure 2-4 on page 2-13,

Measured trench width = 30"

Measured difference in height = 5"

1. Determine the maximum safe vertical of the layer.

Divide the width by 4:

$$30/4 = 7\frac{1}{2}$$

Maximum safe vertical = 7½"

2. Compare the maximum safe vertical to the measured vertical of 5".

The measured vertical of 5" is less than the maximum safe vertical of 7½". Therefore, the slope of the layers does not require extra shoring (i.e., to the next weaker soil classification).

Although slope is not a critical factor in this example, other conditions at this excavation may call for additional shoring.



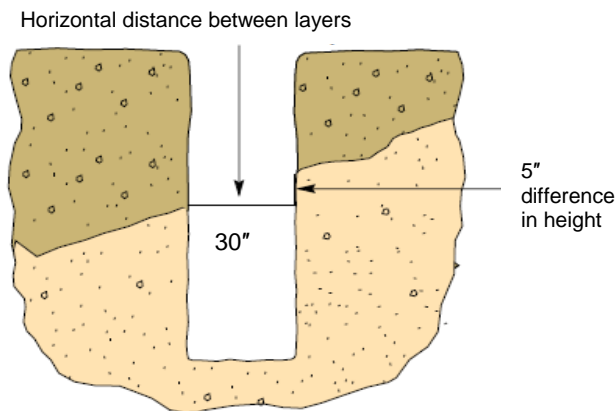

**Figure 2-4. Determining the slope of a layered system**

## 5.8 Working near structures or heavy machinery

Heavy loads such as foundations and large machinery exert a downward and outward force on the soil. This force is concentrated in a sector that extends 45° (a slope of 1:1) downward and outward from all sides of the load (base of the foundation or truck/machinery).

An inadequately-supported excavation intruding into the area that supports a structure may damage the structure and may be more likely to cave in. See Figures 2-5 and 2-6 on page 2-15. If the excavation will cut through the portion of the soil that is subject to the force of the foundation, **before** excavating, get help from a registered P.E.

If the building rests on piles, the force of the foundation starts at the bottom of the piles. In most cases the depth of the foundation or footing is unknown. If you do not feel comfortable assessing the foundation, **before** excavating, either draw the imaginary 45° line from grade level, or get help from a registered P.E.

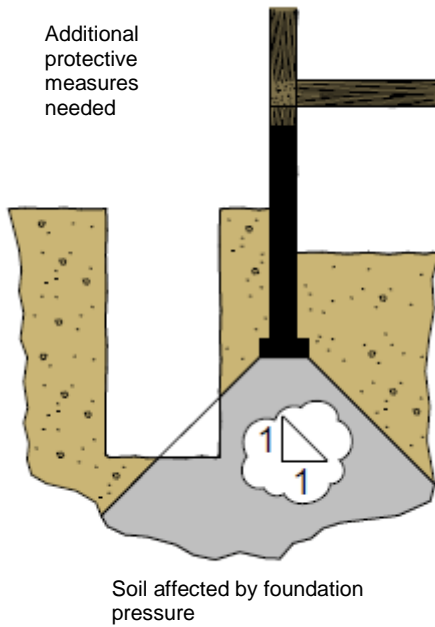

**Figure 2-5. Excavation intrudes into area affected by weight of building**

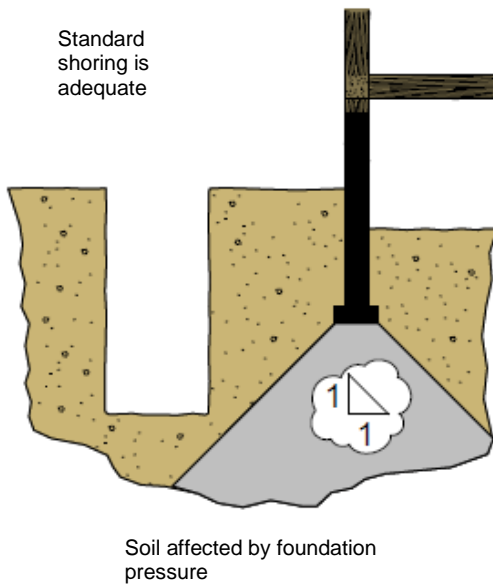

**Figure 2-6. Excavation unaffected by weight of building**

**NOTE**

Machinery weighing 20,000 lbs. or more is classified as a “heavy load” for this purpose under CAL/OSHA. However, the Competent Person should ALWAYS consider ANY piece of machinery when making this determination.

Like the foundation of a building, heavy loads such as trucks and backhoes also increase stresses on soil. If the surcharge load is 20,000 lbs. or greater, **before** excavating, get help from a registered P.E. See Figure 2-7, below, and Figure 2-8 on page 2-17 to determine whether you need additional shoring for a load such as a truck or heavy machinery.

It is best practice **never** to park or drive a truck or heavy machinery close to the excavation. Keeping a distance equal to the trench depth is required to ensure the load does not put additional stress on excavation walls.

For each excavation near a building or machinery, determine if special shoring or other procedures are required.

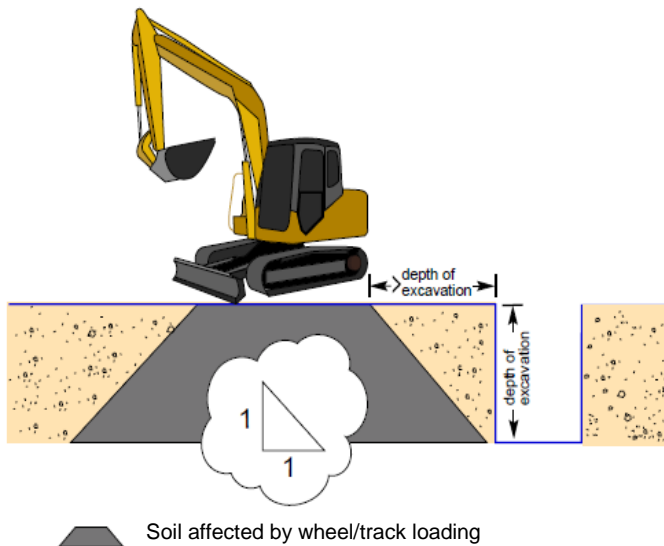

**Figure 2-7. Heavy load nearby; excavation is stable**

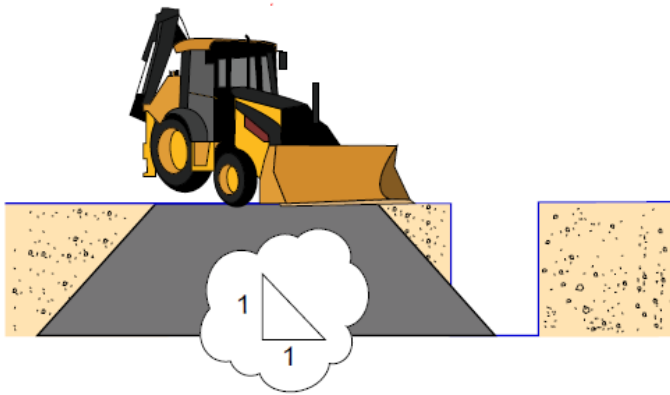

**Figure 2-8. Heavy load nearby; machinery is too close**

In Figure 2-9, below, Trench A is a service trench carrying utilities to the building. The amount of soil removed near the building is minimal and has little or no effect on the foundation of the building. If Trench A were wider or deeper than a normal service trench, there could be some effect on the foundation.

Trench B, however, parallels the foundation and is located close to the building. In this type of case, evaluate the depth of the excavation, the distance to the foundation, and the depth of the building's foundation to determine whether special shoring or other techniques are needed.

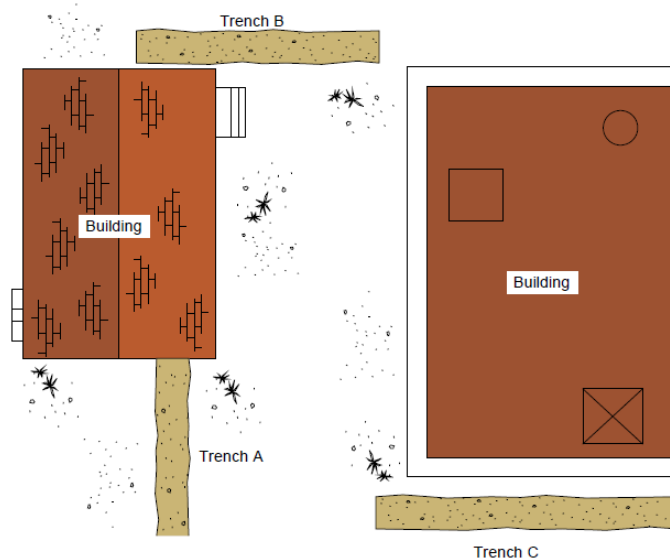

**Figure 2-9. Examples of trenches near buildings**

If the excavation is similar to Trench C in Figure 2-9 on page 2-17, determine whether the excavation will affect the foundation. Compare to Figures 2-5 and 2-6, on page 2-15, in which the area affected by the foundation's force is shown in the darker color.

Use extreme caution when shoring near basements. The outward pressure of the shoring system may cause a failure of nearby foundations and walls. See Figure 2-10, below, for an example.

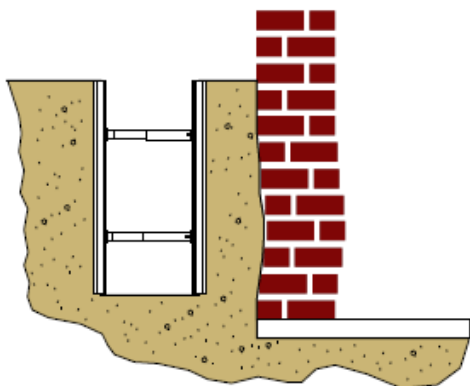

**Figure 2-10. Pressure of shoring damaging basement walls**



## Part 3

# Working Safely

### 1 Excavating

#### CAUTION

Damage to underground facilities may occur if excavations are performed without a current USA ticket. USA tickets are **REQUIRED** and valid for 28 days from the date issued.

#### 1.1 Digging with power equipment

See Utility Procedure TD-4412P-05, "Excavation Procedures for Damage Prevention," for necessary precautions.

#### 1.2 Spoil placement

##### Temporary spoil

Place temporary spoil no closer than 2' from the surface edge of the excavation, measured from the nearest base of the spoil to the cut. Do not measure this distance from the crown of the spoil deposit. At this distance, loose rock or soil from the temporary spoil is unlikely to fall on employees in the trench.

Place the spoil so that it:

- Channels run-off water away from the excavation.
- Cannot accidentally run, slide, or fall back into the excavation.

#### WARNING

The spoil bank must not be higher than 2' if it is located within a distance equal to the depth of the excavation. See Figure 3-1 on page 3-2.

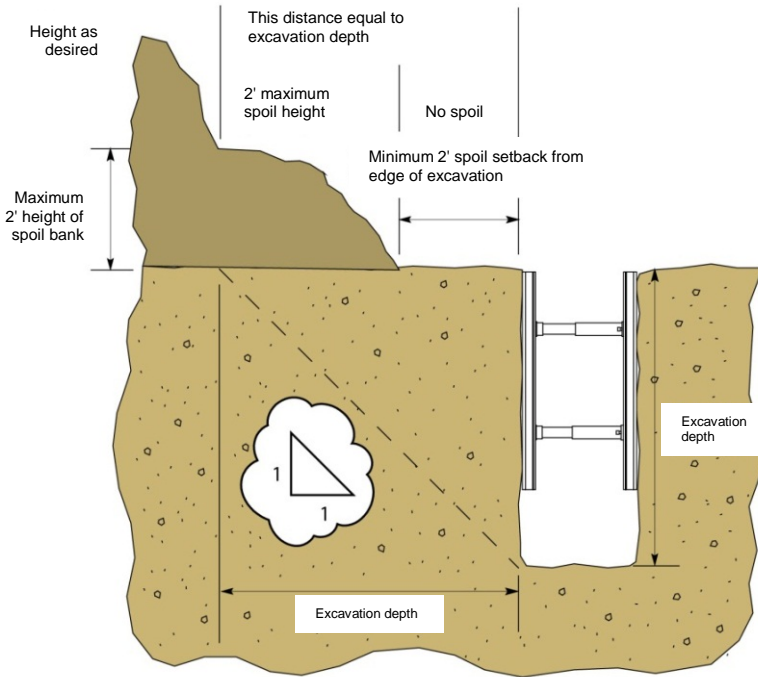

**Figure 3-1. Placing spoil pile at least 2' from excavation**

IF spoil cannot be placed 2' away from the side of the excavation,  
THEN see subsection **Unusual conditions** on page 3-3 for mitigations.

IF the site (e.g., confined city street or site with limited right-of-way) requires either the accumulation of an unusually large or heavy earth spoil pile, or that unusually heavy excavators or trucks travel close to the excavation side walls,

THEN **before** excavating, get help from a registered Professional Engineer (P.E.).

### Permanent spoil

Place permanent spoil away from the excavation. The improper placement of permanent spoil, i.e., at insufficient distance from the working excavation, can cause an excavation to be out of compliance with its H:V requirement. Compliance, or lack of it, can usually be determined through visual observation.

Permanent spoil can change undisturbed soil to disturbed soil and dramatically alter slope requirements.

## Unusual conditions

IF unusual conditions require spoil to be placed within 2' of the edge of the excavation, THEN:

- Include the full height of the spoil when measuring the depth of the excavation.
- Use retaining devices, such as a trench shield, to prevent spoil or other material from falling into the trench.

### EXAMPLE

Figure 3-2, below, illustrates an excavation where the spoil has been placed immediately next to the excavation. The excavation thus counts as 6' deep (2' of spoil, plus the 4' excavation). Do not enter such a trench without protection from a trench shield or other approved safety method.

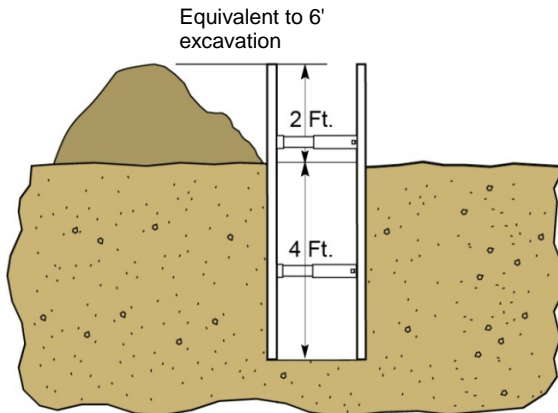

**Figure 3-2. Height of spoil adds to depth of excavation**

## Contaminated soil

If soil contamination is suspected or known,

THEN follow Utility Work Procedure WP4710-02, "Contaminated Soil and Material Handling Procedures," and contact the local environmental field specialist (EFS).

Ensure that the proper PPE is available to all employees handling contaminated soil. The proper PPE is described in Utility Standard S4710, "Gas Pipeline Production Fluid and Liquid; Leak Response and Contaminated Soil Handling Requirements."



## 1.3 Remove hazardous conditions

Make safe or control trees, boulders, poles, or other surface objects that may create a hazard to employees making the excavation. Personnel are not permitted to work on the faces of sloped or benched excavations above other personnel unless personnel at the lower level are protected from the hazard of falling, rolling, or sliding material.

Loose rocks and other objects are hazards that could roll or fall from an excavation face. Protect employees by:

- Removing objects which may fall (such as curbs).
- Scraping excavation faces to remove loose debris (such as rocks).
- Installing protective barriers to stop or contain falling objects.
- Using other means to ensure safety.

## 1.4 Excavating near electric utility structures

Excavations near electric utility structures, including power poles, may be subject to additional hazards. For each such excavation, a Qualified Worker must identify hazards that could cause electric utility structures to become unstable or fall.

Consider the following for hazardous potential:

- Leaning pole or structure
- Heavy equipment on the pole or structure
- Loose soil
- Excavation depth relative to the buried depth of the pole or structure
- Excavating around the entire pole or structure
- Existing excavations
- Guy cables
- Topped poles
- Risers
- Utility (or other) poles
- Ground rods connected to equipment such as cathodic protection rectifiers, transformers, capacitors, regulators, reclosers, etc.

After the Qualified Worker identifies and evaluates potential hazards, controls must be put in place to reduce or eliminate the hazards before beginning the work.

Contact the local Division or General Construction electric supervisor with any questions or concerns and for assistance to secure or support power poles or structures, if deemed necessary to ensure the safety of employees who will be performing the work and to protect Company assets.

## 2

## Preparing to enter an excavation

This section explains the steps and considerations which must be taken to ensure safety before entering an excavation.

### WARNING

If employees must cross a trench that is wider than 30" and deeper than 6", they must use a walkway (with standard guard rails) that is at least 24" wide and made of timber of at least 2" nominal thickness or plywood at least 1- $\frac{1}{8}$ " thick. See Appendix C for illustrations of typical walkways.

### 2.1. Hazards associated with shoring and working in excavations

Safety Procedure SHC 232, "Other Confined Space/Confined Space Entry and Work," Attachment 5, "Entry into Excavations," establishes a consistent process for entry into excavations. Follow this process.

#### Hazardous atmospheres

Under ANY of the following conditions, follow Safety Procedure SHC 232, Attachment 5.

- A hazardous atmosphere exists.
- A hazardous atmosphere can reasonably be expected to exist.

Testing must be performed prior to any employee breaking the plane of an excavation which may contain a hazardous atmosphere.

## Confined space

The excavation is a confined space if both of these conditions are true:

- Insufficient ventilation: The existing ventilation is insufficient to remove dangerous air contamination or improve an oxygen deficiency that may exist or develop.
- Limited access: Access or egress for removing a suddenly disabled employee is impaired because of where or how big the openings are.

For more on confined space operations, see Safety Procedure SHC 232.

## Safety around hydraulic shoring fluid

When using hydraulic shoring, consult the latest Safety Data Sheet (SDS) for current information on hydraulic fluids. Follow all the precautions listed on the SDS.

When requesting an SDS from the current vendor, supply the following information:

- Product name
- Manufacturer's name
- UPC code (if any)

## Safety at heights

Excavation areas may present fall hazards. M62 1073, the Safety at Heights User Guide (Rev. 3/03) states:

It is PG&E's policy that employees not be exposed to fall hazards. When practicable, work areas and processes will be designed or retrofitted to eliminate fall hazards. If the hazard cannot be practicably abated through design, and the potential fall distance is six ft or greater, approved fall protection systems shall be employed where feasible. Where the use of a fall protection system is not feasible, approved work procedures shall be implemented to protect employees from falls.

Consistent work procedures shall be established and applied for similar fall hazards. All employees shall be trained to recognize and abate hazards and to implement control measures as appropriate.

Further information about fall protection is contained in Utility Standard D-S0421, "Fall Protection and Prevention."

## Changes in environment or jobsite conditions

Changes in soil conditions at excavations may require an upgrade in shoring protection. Always watch out for any changes in work area soil conditions that could promote soil collapse. Examples of changes:

### **Moisture**

As soil dries on exposure to air, the soil may crack and destabilize.

### **Vibration**

Shoring requirements increase if there is vibration near the excavation from traffic, heavy machinery, pipeline flow, trains, etc. Pay especially careful attention when vibration is present.

### **Water**

Water from rain, leaks, or water table changes may increase shoring requirements. Porous soils (gravels, sands, and silts) allow water to flow more easily than clay soil. Porous soils may also show the presence of water more quickly than clay soils do.

If you are unfamiliar with soil conditions in the work area, dig a test hole to the depth of the planned excavation. Cover the hole and leave it overnight. The depth of water in the hole the following day is a good indication of the location of the water table.

Do not discharge contaminated water into the environment.

Any personnel on the jobsite who recognize or suspect a hazard have both the authority and the responsibility to call “Stop Work” and evacuate personnel from the excavation. The Competent Person then evaluates the hazard and takes action to control it.

## Hazards associated with water accumulation

### **WARNING**

Do not work in excavations with accumulated water or in excavations where water is accumulating.

Worker protection may include special support or shielding systems to prevent cave-ins or water removal to control the level of accumulating water, and may also require use of a safety harness or lifeline.

The Competent Person does the following:

- Monitors the removal of accumulated water
- Ensures that any necessary environmental notifications are made.
- After the water has been removed, inspects the excavation and shoring.
- Before starting work, makes any necessary adjustments to the protective system.

To restore integrity to areas of the excavation washed away by water, fill voids. See Figure 3-3, below.

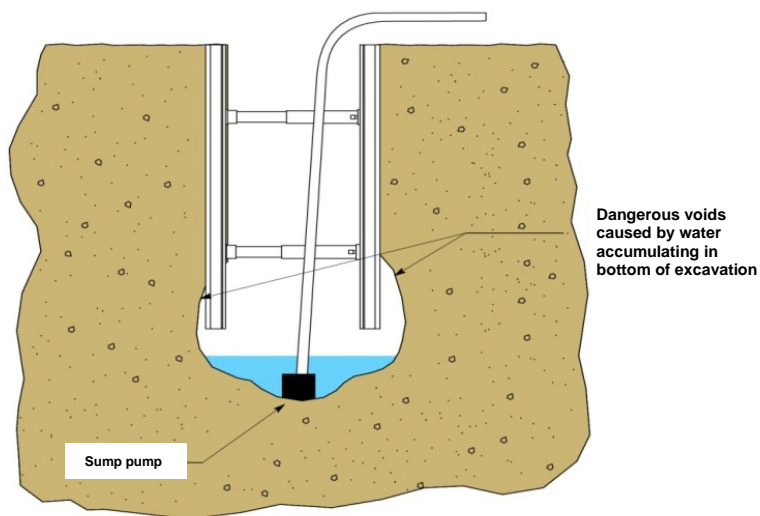

**Figure 3-3. Wet excavation walls collapse, causing dangerous voids**

### Getting into and out of the excavation

Workers need a safe and convenient means of access to enter and leave excavations. Trenches 4' deep or deeper must have exits no more than 50' apart. No one should be farther than 25' from a ladder or other means of exit.

Ladders, stairways, or earthen ramps must meet the following requirements.

#### **Earthen ramps**

- Slope less than 3:1 H:V.
- Allow walking upright.
- Sides protected by shoring, shielding, sloping or benching.

**Structural ramps**

- Designed by a Competent Person or registered P.E.
- If 6' or higher, include a guardrail compliant with requirements specified in Appendix C.

**Ladders**

- Extend at least 36" above the surface.
- Secured mechanically or held by an employee when used.
- Approved in the *Ladder Safety Handbook*.
- See the Code of Safe Practices for more ladder requirements.

Cross the excavation only where it is safe to do so. Do not jump across the excavation.

If employees must cross a trench that is wider than 30" and deeper than 6', they must use a walkway with standard guard rails that is:

- At least 24" wide and
- Made of either timber of at least 2" nominal thickness, or plywood at least 1½" thick.

See Appendix C for illustrations of typical walkways.

## 2.2 Installing protective systems

Refer to Parts 4, 7, 8, and 9 for instructions on protective system installation and requirements.

To ensure the safety of workers and the integrity of the job, install trench protection properly. When installing protective systems:

- Securely connect members of the protective systems selected.
- Safely install support systems.
- Never overload members of support systems.
- When you have to remove individual members temporarily, install other structural members to carry the load.

You may excavate 2' or less below the bottom of the members of a support or shield system of a trench if:

- The system is designed for and adequate for the full depth of the trench, and
- While the trench is open, there are no indications of a possible cave-in below the support system.

# 3 Zone of shoring

It is important to understand which areas of an excavation are NOT protected by shoring

## 3.1 Side walls

When shoring is used to protect the sides of the excavation from cave-in, the shoring supports, and therefore protects, **only part** of the opposing sides. The area between the protecting shores is called the **zone of shoring**. Employees may not enter any area outside the zone of shoring.

### EXAMPLE

In Figure 3-4, the four shores create a zone of shoring. Employees who are between any two shores are **inside** the area protected by the zone of shoring. An employee who is not between two shores would be outside the zone of shoring. Always work inside the zone of shoring.

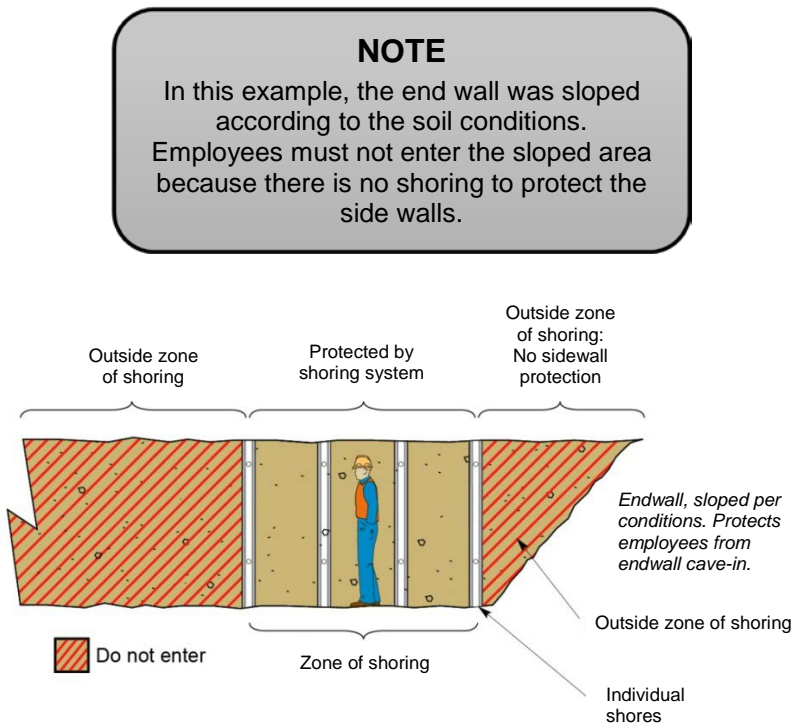

Figure 3-4. Zone of shoring

## 3.2 Trench ends

### WARNING

Do not enter the unprotected trench ends for a distance equal to the depth of the trench.

Just as potential side wall failure creates no-work zones, the risk of end-wall failure also creates no-work zones. The end-wall defines the end of the trench as follows:

**The end of the trench is a distance into the trench equal to the height of the end wall.**

For example, if the end wall is 10' high, the end of the trench includes all of the trench that is 10' or less from the end wall.

The ends of trenches are not included in the zone of shoring established by the side wall shores. Trench ends must be stabilized by sloping, benching, or appropriate shoring (commonly called an end shore.)

It is a best practice to place your last shore at the end of the safe zone. That way, it serves as a reminder that as long as you remain within the shoring, you will not enter the endwall hazard zone. See Figure 3-5.

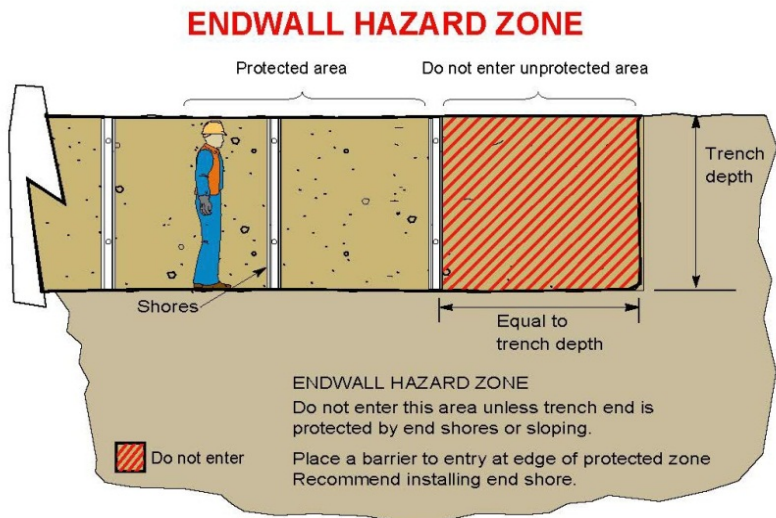

**Figure 3-5. Avoiding unprotected trench ends**



## 4

## Maintaining safety in the excavation

### 4.1 Inspections

#### Inspections by CAL/OSHA or other regulators

An excavation may be inspected by a CAL/OSHA or other regulator. See Appendix B, “Foreman’s Guide for Briefing Cal/OSHA Inspectors,” for instructions on what to do and what information you should be prepared to discuss should that happen.

#### Competent Person inspections

For a detailed explanation of inspection points, see TD-4621S, Attachment 1, “Daily Excavation, Trenching & Shoring Safety Checklist/Report.”

A competent person must inspect the excavation, the adjacent areas, and the shoring, shielding, benching, or sloping system(s) on the following schedule:

- Daily and at the beginning of each work shift.
- After every rainstorm or other hazard-increasing occurrence.
- As needed throughout the shift.

If any of the following conditions are present, evacuate all employees from the hazardous area until the necessary precautions have been taken to ensure safety.

1. Inspect the excavations, the adjacent areas, and the protective systems for evidence of the following:
  - Situations that could result in a cave-in.
  - Indications of protective system failures. Hydraulic cylinders must be maintained at 750–1500 pounds per square inch gauge (psig), or as specified in the vendor’s tabulated data. See Part 4.
  - Hazardous atmospheres.
  - Other hazardous conditions.
2. Inspect the soil for the following factors that can change the classification:
  - Vibrations.
  - Moisture loss.
  - Water intrusion.

## 4.2 Public crossings

If the public must cross the trench, provide a convenient walkway or bridge. This crossing must have standard guardrails that include toprails, midrails, and toeboards. As needed, build in enough space for disabled persons. Additional barricading may be necessary to protect the public. See Appendix C.

Pedestrian crossings that use steel traffic plates require a nonslip coating on the metal plate. All openings in the plate (e.g., the lifting eye) must be covered.

For a description of acceptable guardrails, see Appendix C.

### NOTE

Before using a crossing, verify that it is acceptable and follows codes and standards local to the area of the excavation.

Crossing ramps may be obtained from shoring vendors provided they meet or exceed the company requirements, or are accompanied by stamped tabulated data. Shoring must be used in excavations when the public may be crossing.

## 4.3 Jobsite access and traffic control

When the excavation must be open for multiple days, follow the *California Joint Utility Traffic Control Manual* and *Jobsite Access and Traffic Control*, as well as any permit requirements for closing the excavation each day and reopening it for work subsequent days. See the Traffic Control Plan (TCP).

Install and remove steel plates in accordance with Company standards and procedures.

### WARNING

It is absolutely critical that no unauthorized persons enter the excavation. Secure the excavation before leaving for the day by covering it with steel plates, securely fastening plywood, or using other means that ensure no one can access the excavation.

## Excavation barriers

Use boundary markers, traffic cones, barricades, stop logs, or observers to prevent mobile equipment from accidentally falling into excavations.

When the public is exposed to excavations, use barricading for protection. Backfill trenches or cover them with steel street traffic plates at the end of the work shift. If you are unable to maneuver a steel plate to the excavation, obtain permission from your supervisor to cover the excavation with securely fastened plywood or other means to ensure that no unauthorized people can access it.

**This is critical.** Secure all excavations before leaving for the day. After completing temporary excavations, consider installing shoring for steel-plate-covered excavations in trafficked areas, regardless of depth.

Work area protection must also include measures to safely direct traffic around the excavations. For more information on appropriate work-area protection procedures, consult the *Work Area Protection Guide*.

## Traffic barriers

Where conditions permit, consider parking a large vehicle between the excavation and normal traffic flow. The vehicle can act as a two-way barrier, protecting the excavation and employees from traffic and protecting the public from the trench. Park the vehicle far enough away from the excavation to avoid additional stress on the trench wall.

Consider use of arrow boards to direct traffic around the excavation.

## Non-traffic areas

If backfilling is not practical, secure the area to prevent public access to the excavation. At a minimum, install barricades secured to one another, barricades with fencing, steel plates, or other acceptable controls in a manner that deters public access. If using plywood, fasten it securely to ensure that no unauthorized people enter the excavation.



## Part 4

TD-4621M, Rev. 1  
Publication Date: 7/23/2014  
Effective Date: 1/1/2015

# Protective Systems: Shores and Shields

1

## About protective systems

The protective systems described in this part are a mechanical means of stabilizing the walls of an excavation to ensure the safety of personnel working in the excavation.

This part discusses:

- Hydraulic Shoring
- Boxes
- Shields
- Walers

For preparation and processes, see Parts 2 and 3. To evaluate protective systems not detailed in this chapter or installed by a third party, see Appendix D.

### 1.1 Installing shoring

IF the jobsite requires an employee to deviate from the requirements in this manual,

THEN the deviations must be specified by a registered professional engineer (P.E.) or stamped tabulated data.

Install hydraulic shoring according to the manufacturer's recommendations and the specifications outlined in this manual.

**Install shoring from the top of the excavation and work down to the bottom.**

### 1.2 Removing shoring

Use extreme caution when removing the shoring. Work slowly and be alert to the formation of cracks in the edges of the excavation. Watch for soil movement after removing the supporting systems.

For added safety, backfill up to the bottom shoring braces before removing them.

**Remove shoring from the bottom of the excavation and work up to the top.**

2

## Hydraulic shoring

### 2.1 Advantages

Hydraulic shoring is:

- **Safe:** Employees do not enter an excavation to install shoring.
- **Low-cost:** Generally more economical than other types of shoring.
- Readily **available**.
- **Consistent:** Construction of the rails and cylinders makes the strength of the shoring system much more consistent than other shoring systems.

#### WARNING

Pressure can bleed off overnight. The Competent Person must monitor the performance of hydraulic shoring during regular inspections.

### 2.2 Removing the pins from hydraulic shoring

#### WARNING

Follow all restrictions in the vendor's tabulated data when using hydraulic shoring with pins removed.

In some locations, existing facilities block the installation of vertical hydraulic shores as integral units (rails and cylinders pinned together). Some manufacturers allow their hydraulic shoring systems to be used with the pins removed (pins that usually connect the cylinder pads and vertical rails). When using the hydraulic shoring with the pins removed, personnel must keep at the jobsite a copy of the vendor's tabulated data authorizing the use of unpinned shores. Alternatively, consider using a waler system in these situations.

Figure 4-1 on page 4-3 shows an example of typical tabulated data.

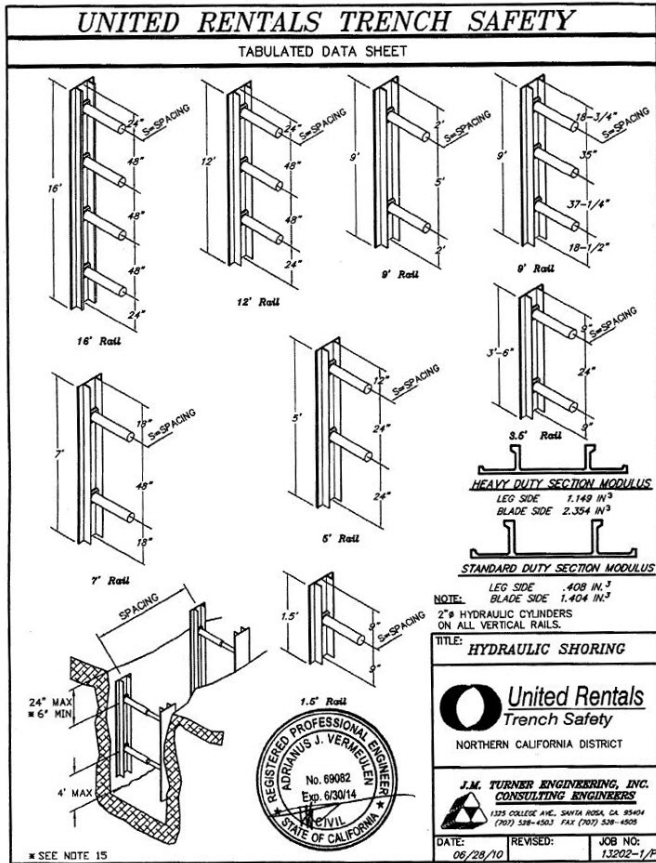

**Figure 4-1. Tabulated data example. Used with permission from United Rentals.**

*Tabulated data shown here is only an example. Always have current, stamped tabulated data on site.*

### Additional safety issues

- Always work inside the zone of shoring. See Part 3, “Working Safely,” Section 3, Figure 3-4.
- Do not remove any part of the shoring system of any excavation until all necessary steps are taken to prevent hazards to employees.

## 2.3 Installation requirements

### General

Install shores according to the manufacturer’s directions.

Do not apply any vertical loads to the hydraulic cylinders (do not use them as ladders; do not use them to support scaffolding).

The vertical rails directly behind each hydraulic cylinder pad must bear on firm soil or on a solid and stable filler to distribute the cylinder load to the face of the excavation.

Inspect before each use and remove from service any damaged material a Competent Person cannot assure is safe for use. Return damaged material to the vendor for evaluation and approval by a registered P.E. before being returned to service.

Do not use shoring that has evidence of:

- Leaks
- Damaged hinge points
- Missing/removed parts
- Deformed components
- Broken connections
- Cracked nipples
- Bent bases
- Other damage

Table 4-1, below, shows the minimum number of shores required.

For spacing requirements based on soil type, always refer to the data in Parts 7, 8, and 9. **Regardless of the length or depth of the excavation, there must be a shore within 2’6” of each end of the excavation.**

**Table 4-1. Minimum number of required shores**

EXCAVATION		MINIMUM REQUIRED
DEPTH	LENGTH	
Up to and including 12’ deep	12’ long or less	3 sets of shores at required spacing (or closer)
	More than 12’ long	3 sets of shores (4 preferred)
More than 12’	All	4 sets of shores

*You may use a different number of shores if specified by a registered P.E. or stamped tabulated data.*

Ensure that shoring material is inspected by a Competent Person before installation, daily during use, and when the Competent Person changes. Unfold the hydraulic shoring and inspect the components. Inspect as described on page 4-4.

Ensure that vertical rail overlaps sheeting material 4" when shores are installed on a seam between two adjacent sheets of sheeting material. Ensure that sheeting material is held rigidly against each trench wall by hydraulic shoring. Table 4-2, below, lists Company-approved sheeting material. Stamped tabulated data may differ.

**Table 4-2. Requirements for wooden shoring components**

MATERIAL	SPECIFICATION	SPECIAL CONSIDERATIONS
Plywood	1½"-thick American Plywood Association (APA), C-C or C-C Plugged Grade, Exterior Glue Bond. Verify that each sheet of plywood is stamped with APA, the specified grade (e.g., C-C), and type of glue (e.g., exterior)	Never substitute other types of plywood (e.g., CD, CDX), unless specified by a registered P.E. or stamped tabulated data
FinnForm or Euroform composite	¾" thick, 14-ply, arctic white birch (FinnForm)	No substitution, unless specified by a registered P.E. or stamped tabulated data

Install hydraulic shores with the rails vertical and the hydraulic cylinders horizontal. Offset the rails vertically to ease their installation and removal (see Figure 4-2 on page 4-6).

Figure 4-3 on page 4-6 shows a side view of the shore placement. The horizontal distance between the shores is determined by soil type and excavation depth. See Parts 7, 8, and 9 for required spacing.

Use these rules when placing shores:

1. The centers of the hydraulic cylinders must be:
  - No more than 18" below the surface of the ground.
  - No more than 4' between the centers of the hydraulic cylinders.
  - No more than 2' of earth exposed between the rails vertically. See first two rails in Figure 4-2.
  - No more than 48" from the bottom of the trench.
  - No more than 2'6" from the trench end. Further than that will create a "no work zone."
2. The rails may be unpinned from the struts if the vendor's tabulated data allows the separation (see Part 4, Section 2.2 on page 4-2).



**NOTE**

If desired, butt the ends of the shores together to place them in a single vertical line.

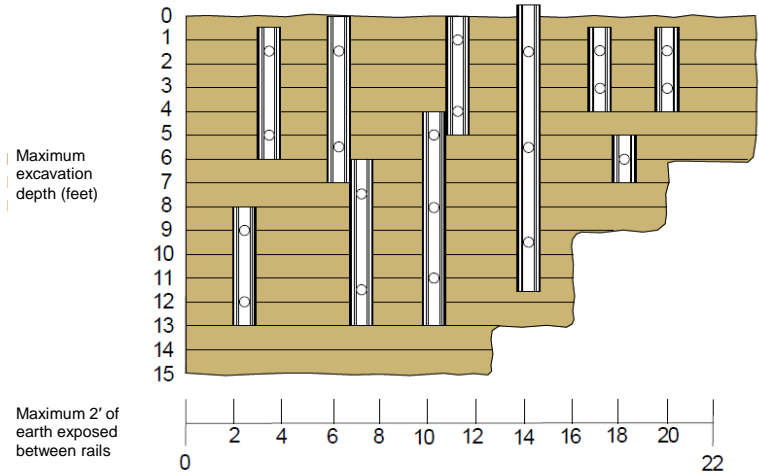

**Figure 4-2. Sample placement of hydraulic rails**

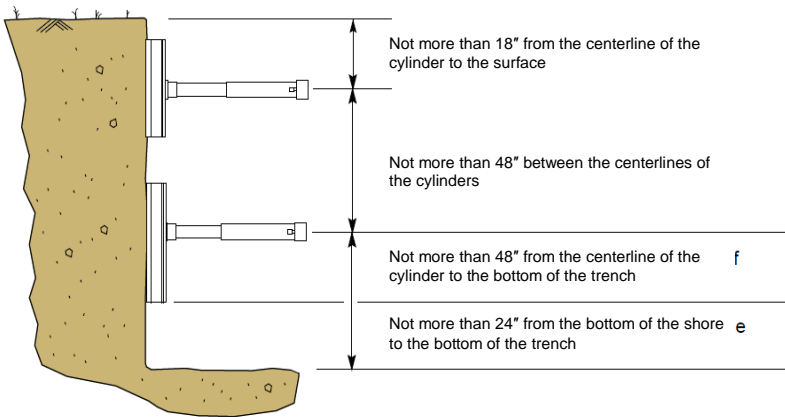

**Figure 4-3. Sample placement of hydraulic shores**

**WARNING**

Do not butt rails end to end across an excavation.

## Tilting shores

Shores are designed to be installed vertically. They may be installed horizontally or diagonally if all the provisions of the tabulated data are satisfied.

## Waler systems

Waler systems are available should a longer working section be needed. See Parts 7, 8, and 9 for tables on waler systems. In a waler system, the shores are oriented horizontally in the trench. This allows maneuvering around obstacles in the trench, such as pipelines.

# 3

## Trench shields, boxes, or cages

### Shields

Trench shields, also called boxes or cages, can provide a convenient way to solve difficult shoring problems. Trench shields are intended primarily to protect workers from cave-ins or similar incidents. Shields are available in many sizes, shapes, and strengths. Contact an approved vendor for tabulated data on the shields that are available for use in your area.

Shields must extend to the top of the excavation and not leave more than 2' of exposed earth at the bottom.

Figure 4-4 shows one kind of shield.

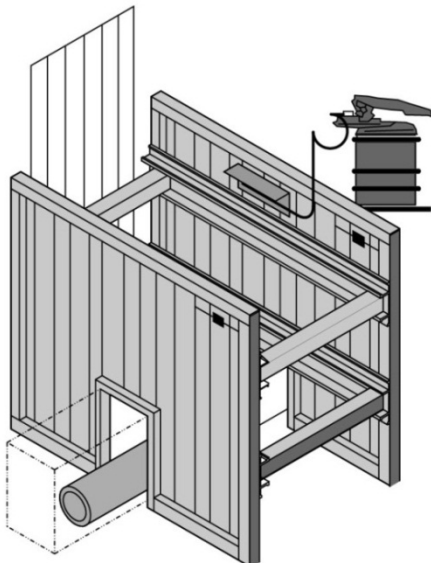

**Figure 4-4. Example of hydraulic shield**

## Condition of materials

Ensure that all trench shields, boxes, or cages, and associated materials are free of defects and damage that might in any way impair their protective function. Immediately remove from service all questionable materials.

Inspect materials prior to installation and report all damage promptly. All damage must be evaluated and repairs made by the vendor's approved representative. Cal/OSHA code requires that a P.E. evaluate and approve the equipment repair prior to returning it to service. Missing or damaged parts must be replaced with parts approved by the vendor.

## The excavation

The excavation must be large enough to easily accommodate the trench shield, but the distance between the outside of the box and the trench face should be as small as possible. When the shield is in place, backfill the space outside the shield to prevent it from moving. Fill the space to approximately  $\frac{1}{2}$  to  $\frac{2}{3}$  the excavation's depth if possible. Using washed rock makes shield removal easier.

The faces of the excavation must be cut near vertical and must be straight. The gap between the shield and the excavation face must be no more than the distance specified by the vendor's tabulated data.

## Lifting and placing components

### WARNING

The top of the excavation must not be above the top of the shield. Slope the sides of the excavation, if necessary, to provide proper clearance.

Inspect all lifting and pulling equipment (cables, slings, chains, shackles, safety hooks, etc.) that is used to handle shields. Evaluate all the components to ensure adequate lifting capacity.

Use tag lines or other approved safety devices to keep employees away from the loads handled by the lifting equipment. Do not stand in or under shields when they are being lifted or moved.

When placing the shield, move slowly, restrict lateral or other hazardous movement of the shield in the event of sudden lateral loads, such as wind loading.

In a compound excavation, the sides of the shield must extend 18" above vertical walls. Figure 4-5 on page 4-9 shows an example in Type B soil.

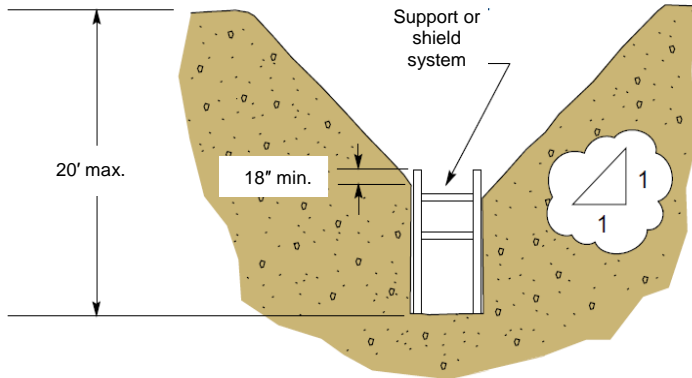

**Figure 4-5. Example: Type B soil, supported or shielded**

### Stacking shields

Some shield units may be stacked for additional depth. Follow the vendor's tabulated data for stacking shields.

When stacking shields, consider using a separate sling for each shield section. This eliminates the need to enter any unprotected portion of the excavation to attach or remove tag lines from the shield sections when installing or removing the shield sections.

### Entry/Exit

The climbing rungs built into shields **do not meet** the requirements for entry and exit. Install approved ladders in the shield. Ladders must be secured and must extend at least 36" above the top of the shield.

### Do not enter an unprotected area

When installing, moving, and removing the shield:

- Employees must always be protected.
- Employees must not be in the shield.
- Employees must not enter an unprotected area.

Never enter or exit the shield through unprotected areas.

4

# Protective systems: typical installations

## 4.1 Shoring bell hole with perpendicular corners

Figure 4-6, below, shows how shoring can protect a bell hole that has right-angle corners. Install the shores using the spacing recommended in tabulated data.

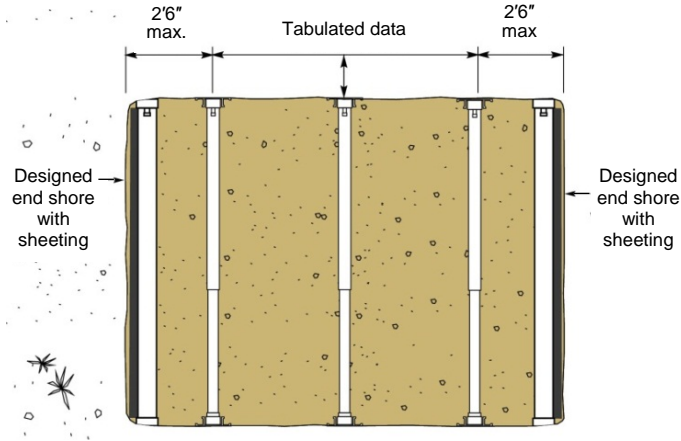

Figure 4-6. Typical bell hole with shoring (plan view)

## 4.2 Protecting a T intersection

The T intersection presents special problems. Figure 4-7, below, shows how to use a trench shield in addition to shoring to protect the work area.

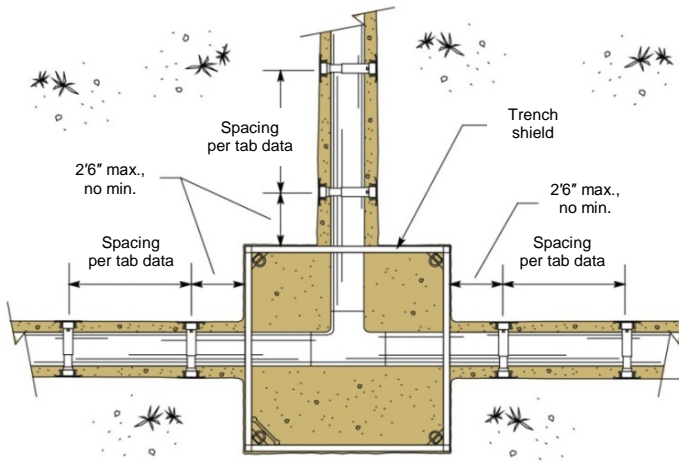
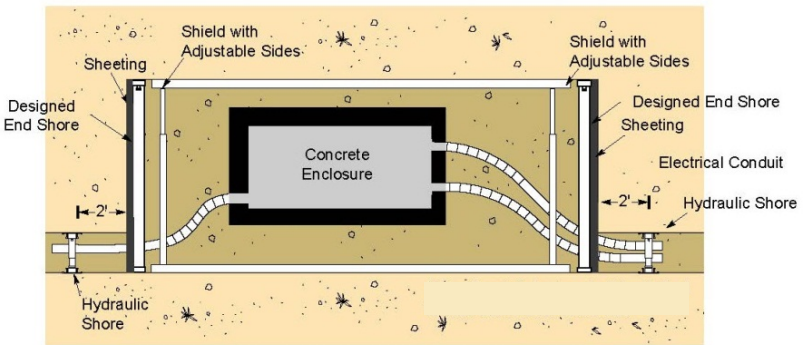

Figure 4-7. Protecting a T intersection (plan view)

### 4.3 Shoring around a box

In this installation, hydraulic shoring is used to span the area in the excavation that will contain the box. Choose shoring members from vendor's tabulated data. The trench is protected with conventional shoring.

Figures 4-8 and 4-9 show examples using #5 boxes. Conduit angles must be limited to the maximum allowed for the cable size.



**Figure 4-8. Shoring the #5 box, option 1**

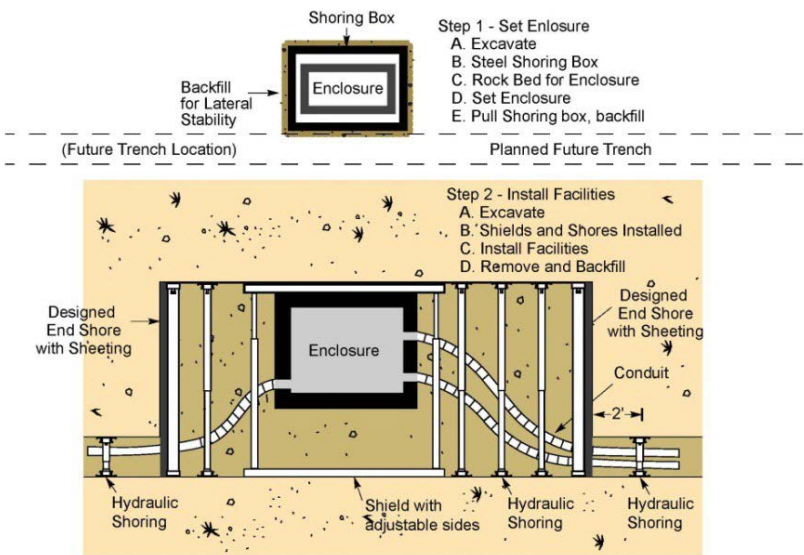

**Figure 4-9. Shoring the #5 box, option 2**

THIS PAGE INTENTIONALLY  
LEFT BLANK



# Part 5

## Sloping and Benching

### 1 Sloping excavation walls

#### 1.1. Why slope?

Sloping is the simplest way to prevent a cave-in. In sloping, trench walls are cut back to create a V shape. When the correct slope is used, the sides of the excavation are stable and will not collapse.

Figure 5-1, below, is an example of a typical sloped excavation for Type A soil.

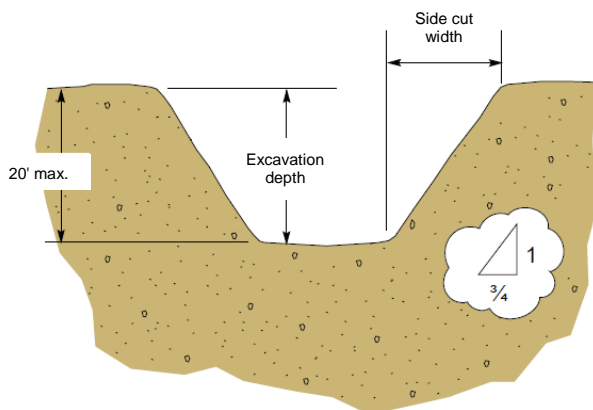

Figure 5-1. Typical sloped excavation for Type A soil

#### 1.2. Profile of simple slope

The slope angle depends on the soil type. The maximum slope for each soil type is shown in Table 5-1 on page 5-2.

#### NOTE

Based on local conditions, you may choose to make the slope shallower (less steep) than the maximum slope permitted in Table 5-1.

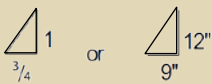
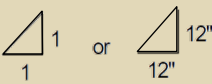
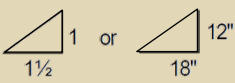

**Table 5-1. Maximum slope for different soil types**

SOIL TYPE	MAXIMUM PERMITTED SLOPE	MAXIMUM ANGLE
A	$\frac{3}{4}:1$ H:V 	53°
B	$1:1$ H:V 	45°
C	$1\frac{1}{2}:1$ H:V 	34°

IF an excavation face is sloped at the maximum permitted slope and shows signs of distress (spalling, raveling, clumps separating), THEN the run (horizontal) must be increased by  $\frac{1}{2}$ . For example, a  $1\frac{1}{2}:1$  H:V slope in Type C soil must be increased to  $2:1$  H:V.

Additionally, a Competent Person must determine whether the slope should be adjusted (reduced, or made less steep) due to the presence of heavy machinery.

For details on constructing various sloping systems for each soil type, see:

- Part 7 (Type A soil)
- Part 8 (Type B soil)
- Part 9 (Type C soil)

## 2

## Sloping and vertical wall combinations

Digging with a vertical wall requires less soil to be removed and is faster than conventional sloping.

### NOTE

Sloping with short vertical wall combinations without shoring is permitted in Type A soil only.

## 2.1 Sloping with short vertical walls

On occasion, you may need to use one of the methods shown in Figures 5-2 and 5-3, below. Note that the maximum depth of the excavation is limited by the slope.

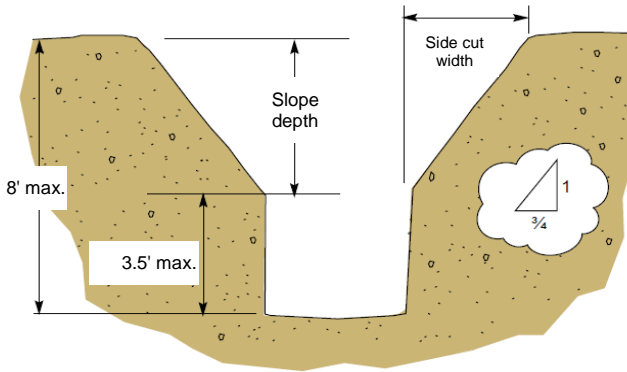

**Figure 5-2. Type A soil,  $\frac{3}{4}$ :1 H:V sloping with initial vertical wall**

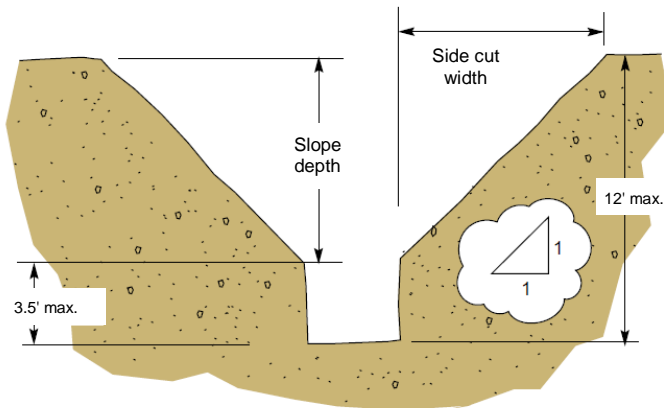

**Figure 5-3. Type A soil, 1:1 H:V sloping with initial vertical wall**

### 3

## Benching an excavation

Benching is an alternative to shoring or sloping. A bench is composed of a short vertical rise and a horizontal step at the top of the rise.

Benching is authorized only for Type A and Type B-cohesive soils, which can hold the verticals in a benched excavation.

Choose the dimensions of the bench based on all of the following:

- The soil type
- The nature of the work to be done
- The depth of the excavation

The steps of the bench rise at the same slope as for a sloped excavation.

See Parts 7 and 8 for details on proper benching for each soil type.

**Table 5-2. Required Benching Slopes**

SOIL TYPE	REQUIRED SLOPE
A	$\frac{3}{4}$ :1 H:V, 9"H:12"V
B Cohesive	1:1 H:V, 12"H:12"V

You may change the sloped excavation to an excavation with multiple benches or steps. Figure 5-4, below, shows the profile of multiple benches.

Only part of the first horizontal step is allowed to extend beyond the excavation's maximum permissible slope.

For Type B soil, the minimum width of the first horizontal step is equal to the combined heights of the first rise and the second rise, as shown in Figure 5-4.

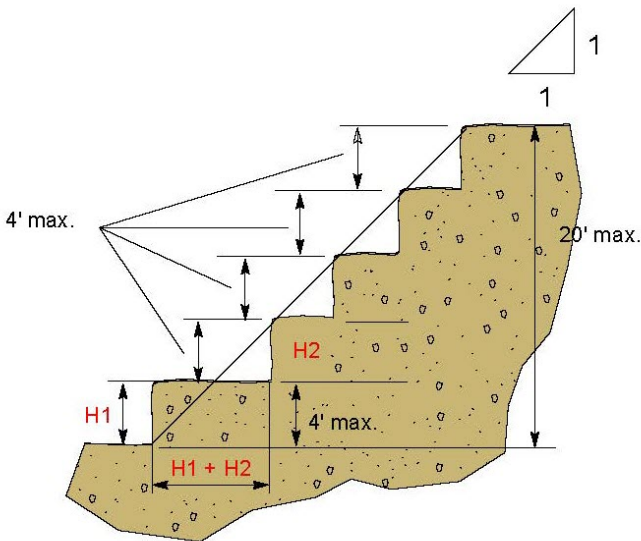

**Figure 5-4. Type B soil, multiple-bench excavation (partial view)**



## Part 6

# Cave-In Emergency Plan

1

## Elements of the cave-in emergency plan

### **WARNING**

Rescue by non-qualified personnel is dangerous.

**Only qualified rescue workers shall attempt a rescue.**

All crews must create and tailboard a basic cave-in emergency plan before installing shoring and before anyone enters the excavation.

A cave-in emergency plan must include requirements for:

- Emergency notifications.
- Locating and using emergency shoring materials, tools, etc.
- Initial “make-safe” actions to stabilize the situation and prevent further cave-in.
- Identifying hazards to both victim(s) and rescuers.

Document these actions on the Job Site Safety Analysis (JSSA). You may use TD-4621S-F01, “Daily Excavation, Trenching & Shoring Safety Checklist,” to address excavation safety, reducing the chance of a cave-in.

### 1.1 Emergency notification

1. IF someone is trapped by a cave-in,  
THEN call 911 immediately for emergency assistance.  
Tell the 911 operator:
  - The location and nature of the incident.
  - The number of victims involved.
  - That people trained in trench rescue are required.

This call initiates an emergency response by medical and qualified rescue personnel.

**NOTE**

Calling 911 does not guarantee that all rescue services have proper training to stabilize a trench or excavate effectively in the event of a cave-in.

2. Evaluate what actions can be taken before emergency services arrive; decide what materials, equipment and personnel are needed.
3. Call Company supervision. The supervisor does the following:
  - Mobilizes Company resources and sends personnel and materials to assist with the rescue effort.
  - Coordinates with the ranking rescue officer throughout the operation to ensure the safety of the victim and the rescue workers.
  - Informs the Safety Department by calling the Helpline at (415) 973-8700, Option 1. Gives the location and emergency actions taken.

**WARNING**

Do not use machinery to dig around a victim. Hand digging is the only way to find the victim's body and limbs.

## 1.2 Supporting an emergency rescue

**WARNING**

A second cave-in can follow a first cave-in. Take precautions to protect those directly involved in the rescue, including the injured.

**NOTE**

Emergency response personnel establish incident command. The Company provides support and takes direction from incident command, or unified command may be established.

**1.2, cont.**

1. Assign a Safety Observer on either side of the excavation to:
  - Monitor the excavation.
  - Identify any present and potential hazards.
  - Inform the Site Supervisor of any changes.
2. Use hand labor (no machinery) to clear spoil and materials from the top edge of the trench.
3. Place plywood or wooden planks at the edge of the trench to distribute the weight of emergency personnel.

**1.3 Stabilizing and entering the excavation****WARNING**

Do not enter the excavation until it has been stabilized.

1. Determine how shoring can be safely lowered into the excavation without endangering the victim.
2. Install shoring to protect rescue workers.
3. Do not allow anyone to enter the trench or excavation until the trench has been stabilized and the foreman or site supervisor deems it safe.
4. The Safety Observer monitors the safety of emergency response workers throughout the rescue operation and notifies incident command of any issues observed.
5. Sample air quality before entering and at regular intervals during the entire rescue operation.
6. Attach lifelines to every person entering the excavation for any reason.
7. A rescue operation is time-consuming. Designate relief personnel to be ready to assist rescuers in first aid and cardiopulmonary resuscitation (CPR).

## 1.4 Caring for a victim

### WARNING

Always assume that a victim has serious back and neck injuries.

If it is possible to safely reach a victim, give care as follows.

1. Clear the victim's face and chest to restore breathing.
2. Perform basic first aid.
  - Restore breathing.
  - Stop the bleeding.
  - Check for broken bones.
  - Perform CPR.

## 1.5 Moving a victim

- **Only** move a victim in a life-threatening situation.
- Take adequate precautions to prevent further injuries.
- Only a properly trained rescue team, using the proper equipment, should move a victim.

## 2

# Cave-in emergency checklist

## 2.1 Call for rescue service

- Call 911 and tell the operator:
  - The exact location of the accident scene. This may include GPS coordinates.
  - The number of victims.
  - The approximate time of the cave-in.
  - The depth of the trench or excavation.
- Help the rescue service understand clearly that they are responding to a cave-in. Some rescue teams have special equipment for a cave-in accident.
- Tell the rescue service about any utilities or other facilities that may create a hazard to the rescue operation.
- Be prepared to stay on the line with the 911 operator to relay information while another employee contacts Company supervision.

## 2.2 Notify Company supervision

- Call the Company dispatcher, gas dispatcher, electric system operator, or other Company office and tell them the:
  - Exact location of the accident scene.
  - Number of victims.
  - Approximate time of the cave-in.
  - Depth of the trench or excavation.
- Request any needed equipment or shoring materials.
- Confirm that local supervision is notified.
- Call the Safety Department Helpline, at (415) 973-8700, Option 1. Be prepared to describe location and actions taken in the emergency.
- Use the contact list in Part 1, section 2.1, to call for other assistance as needed.

## 2.3 Crew foreman or Competent Person's duties

### WARNING

After any cave-in, there is danger of a second cave-in. Take precautions to protect those directly involved in the rescue, including the injured. 65% of cave-in victims are rescue personnel.

- Select crew members for the tasks they are best suited for and trained to perform.
- Stress the importance of immediately relaying progress reports and findings back to the supervisor.
- Keep a log of all significant events.

## 2.4 Prepare site for emergency response

- Document all actions taken and inform emergency response team of the situation upon arrival.
- Shut down equipment and eliminate other sources of vibration.
- Establish a clear work area for emergency equipment of 300' in all directions (if possible).
- Direct traffic away from the scene until police arrive.



**2.4, cont.**

- Establish a staging area at least 50' away for shoring materials, plywood, and other equipment that rescue workers can use to shore the excavation.
- Use all available resources to obtain any needed additional shoring materials:
  - Lumber yards and shoring vendors
  - Construction sites
  - Local service centers, etc.

**WARNING**

Do not enter an unshored excavation cave-in.

- When it is safe, install emergency shoring to prevent a second cave-in and stabilize the excavation. Install the shoring using any system described in the Excavation Safety Manual or other approved, tabulated data.
- Use vacuum excavation, if available, to suck soil or water from the cave-in.

**2.5 Identify hazards**

- Be alert for and identify signs that indicate potential problems like signs of ground movement in the area, cracks, etc.
- Mark trouble areas with paint so they can be monitored.
- Be constantly aware of the possibility of a secondary cave-in.
- IF employees suspect a hazardous atmosphere,  
THEN ventilate the site until the appropriate test equipment takes a safe reading.
- Look for other construction in the area that could possibly compound a hazardous situation.
- Check for utilities in or near the trench that could create a hazard.
- Determine a method to remove water from the excavation, if needed.
- Keep all people away from the excavation, except those involved in the rescue activity.

## 2.6 Caring for a victim

- Move a victim only in a life-threatening situation.
- To care for a victim of an excavation cave-in:
  1. Clear the victim's face and chest to restore breathing.
  2. Perform basic first aid:
    - Restore breathing.
    - Stop the bleeding.
    - Check for broken bones.
    - Perform CPR.
- Always assume that a victim has serious back and neck injuries.
- Take precautions to prevent further injuries.

THIS PAGE INTENTIONALLY  
LEFT BLANK



## Part 7

# Type A Soil

This part discusses requirements, tabular data, and examples for shoring, sloping, and benching in Type A soil.

1

## Characteristics

Type A soil is cohesive soil with unconfined compressive strength greater than or equal to 1.5 tons per square foot (TSF).

Examples of Type A soil:

- Clay
- Silty clay
- Sandy clay
- Clay loam
- Cemented soil (caliche and hardpan)

IF any of the following are true,

THEN the soil **cannot** be classified as Type A.

- Soil is fissured.
- Soil is subject to vibration from heavy traffic, pile driving, or similar effects.
- Soil has been previously disturbed.
- Soil is part of a sloped, layered system where the layers meet on a slope of 4:1 H:V or steeper. See Part 2, Section 5.7.

Other factors may also bar soil from classification as Type A.

## 2

## Hydraulic shoring data

### 2.1 Spacing components

**NOTE**

Use the vendor's tabulated data or the numbers in Table 7-1, below, to determine the required horizontal spacing for shores.

If raveling or sloughing of the excavation face appears likely, use 4'-wide sheeting (approved plywood or FinnForm) at each vertical shore.

2"-diameter cylinders must have one of the following:

- A structural steel tube oversleeve 3.5" x 3.5" x 0.1875" extension (installed over the aluminum oversleeve extension)
- OR
- A steel tube oversleeve 3" x 3" x 0.1875" extension (installed without the aluminum oversleeve) that extends the full retracted length of the cylinder.

The bottom of the sheeting must extend within 2' of the bottom of the excavation.

IF there is an indication of possible loss of soil from behind the support system,  
THEN sheeting must extend to the bottom of the excavation.

When vertical shores are used, there must be a minimum of three shores spaced equally throughout the excavation.

When working near the end of a trench or excavation, and shoring is required, use end shores or other approved methods to protect employees.

See Table 7-1, below, for sample spacing requirements.

**Table 7-1. Type A soil: Cal/OSHA spacing requirements for hydraulic shoring in an excavation up to 15' deep**

MAXIMUM HYDRAULIC CYLINDER SPACING		MINIMUM CYLINDER DIAMETER	
HORIZONTAL	VERTICAL	EXCAVATION 0 TO 8' WIDE	EXCAVATION 8' TO 12' WIDE
8'	4'	2"	2"

## 3

## Shoring examples

Figure 7-1, below, shows shoring in Type A soil.

Use plywood on sides if sloughing or raveling of sidewalls appears likely

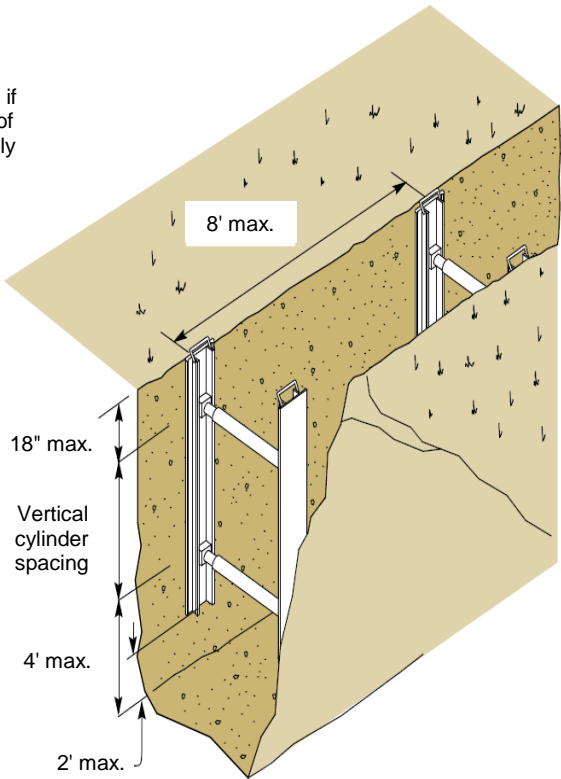

**Figure 7-1. Hydraulic shoring in Type A soil**

### 3.1 Other applications

For excavations that are deeper or wider than listed in Table 7-1 on page 7-2, see the vendor's tabulated data for the excavation system you install. You may also contact a registered P.E. for assistance. See Part 1, Section 2.1 for phone numbers.

## 4

## Sloping

**NOTE**

Maximum depth of an excavation designed using this manual is limited to 20'.  
See Part 10, "Sloping Layered Soil," for sloping layered soil types.

Sloping is permitted in Type A soil. The slope must be no steeper than  $\frac{3}{4}$ :1 H:V (i.e., 9" horizontal to 12" vertical). A profile of the excavation is shown in Figure 7-2, below.

IF an excavation face is sloped at  $\frac{3}{4}$ :1 H:V,  
AND shows signs of distress (spalling, raveling, clumps separating),  
THEN the wall must be sloped to  $1\frac{1}{4}$ :1 H:V.

For example, an excavation face that is sloped at 9" horizontal to 12" vertical and shows spalling must be re-sloped to 15" horizontal to 12" vertical.

See Table 7-2 on page 7-5 for pre-calculated values for sloping in Type A soil.

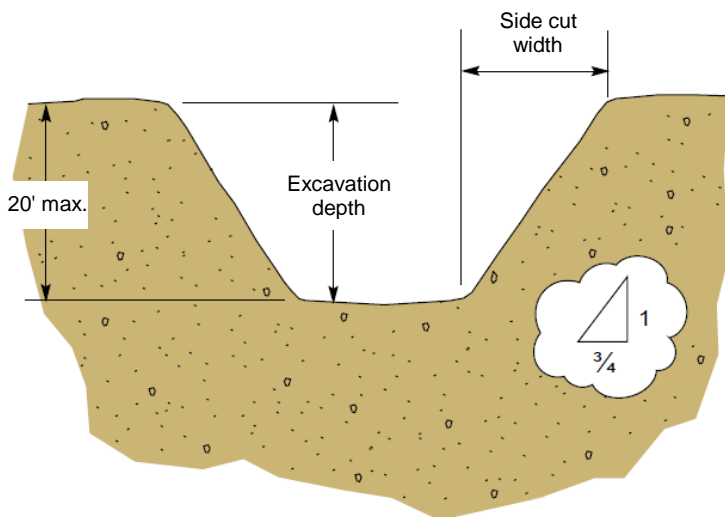

**Figure 7-2. Sloping in Type A soil**

**Table 7-2. Sloping dimensions for Type A soil,  $\frac{3}{4}$ :1 H:V**

EXCAVATION DEPTH	MIN. WIDTH AT TOP OF EACH SIDE CUT (SIDE CUT WIDTH MIN.)
4'	3'0"
5'	3'9"
6'	4'6"
7'	5'3"
8'	6'0"
9'	6'9"
10'	7'6"
11'	8'3"
12'	9'0"
13'	9'9"
14'	10'6"
15'	11'3"
16'	12'0"
17'	12'9"
18'	13'6"
19'	14'3"
20'	15'0"

**Example:**

Given: Work is being performed in a 13'-deep trench.

Determine: The side cut width.

Data from Table 7-2: A 13'-deep trench requires a side cut 9'9" wide.



## 4.1 Supported or shielded sloping

The maximum depth for this method is 20'.

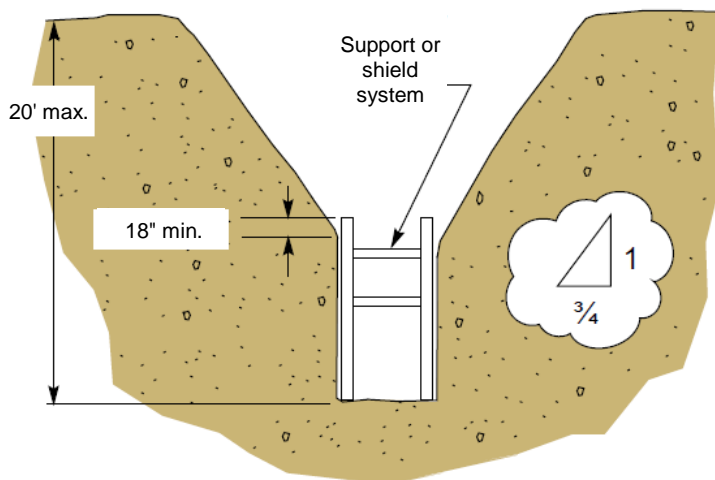

**Figure 7-3. Type A soil: trench shield in sloped excavation**

Design shield or shoring systems to protect the total depth of the excavation and extend at least 18" above the top of any vertical walls.

## 4.2 Unsupported vertical lower walls

Digging with a vertical wall requires less soil to be removed and is faster than conventional sloping. See examples in Figure 7-4 on page 7-7 and Figure 7-5 on page 7-8.

See Table 7-3 on page 7-7 and Table 7-4 on page 7-8 for horizontal dimensions. Note that the maximum allowable depth is determined by the slope used on the walls.

For excavations that are 8' deep or less, use a slope of  $\frac{3}{4}$ :1 H:V or less steep.

The maximum height of the unsupported vertical wall is 3'6".

This trench configuration, shown in Figure 7-4, is permitted only in Type A soil.

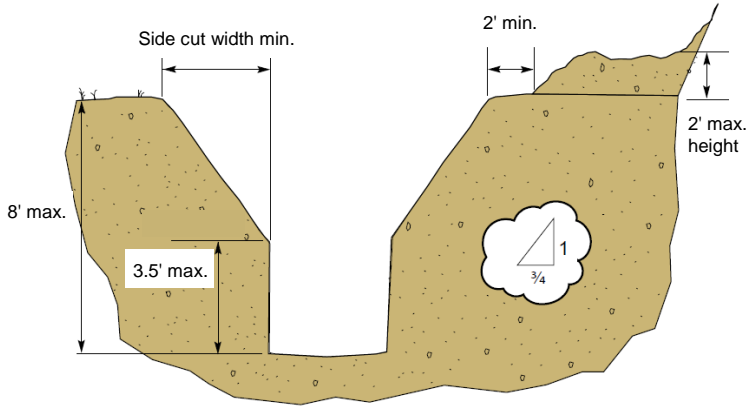

**Figure 7-4. Sloped excavation with unsupported vertical lower walls, maximum depth 8'**

**Table 7-3. Sloped excavation with 3'6" initial unsupported vertical sides (8' max. depth, slope 3/4:1 H:V)**

TYPE A SOIL, 3/4:1 H:V	
EXCAVATION DEPTH	WIDTH AT TOP OF EACH SIDE CUT (SIDE CUT WIDTH MIN.)
4'	5"
5'	1'2"
6'	1'11"
7'	2'8"
8'	3'5"

Excavations deeper than 8' (with vertical side) require a slope of 1:1 H:V.

- The maximum depth is 12'.
- The maximum height of the unsupported vertical wall is 3'6".

This trench configuration is permitted only in Type A soil.

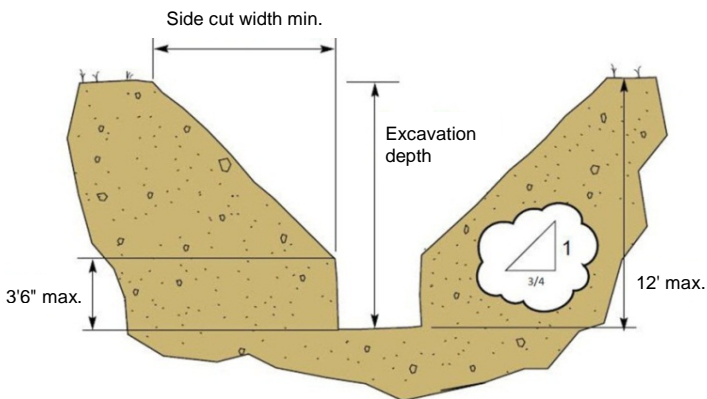

**Figure 7-5. Sloped excavation with unsupported vertical lower walls**

**Table 7-4. Sloped Excavation with 3'6" initial unsupported vertical sides (12' max. depth, 1:1 H:V slope)**

EXCAVATION DEPTH	WIDTH AT TOP OF EACH SIDE CUT
4'	0'6"
5'	1'6"
6'	2'6"
7'	3'6"
8'	4'6"
9'	5'6"
10'	6'6"
11'	7'6"
12'	8'6"

## 5

## Benching

**NOTE**

Maximum depth of an excavation designed using this manual is limited to 20'.

Benching is permitted in Type A soil. The steps of the bench rise at the same slope as for a sloped excavation. The slope must be  $\frac{3}{4}$ :1 H:V or less steep. That is, 9" ( $\frac{3}{4}$ ') horizontal to 1' vertical, or less steep.

A profile of single bench excavation is shown in Figure 7-6, below, and a profile of a multiple bench excavation is shown in Figure 7-7 on page 7-10.

### 5.1 Single bench

The simplest form of benching is the single bench, or an excavation having one vertical rise and a horizontal step. Only the benched section may extend beyond the slope of the remaining excavation wall. Choose the dimensions of the bench based on:

- Soil type
- Nature of the work to be done
- Depth of the excavation

See Table 7-5 on page 7-10 for maximum dimensions.

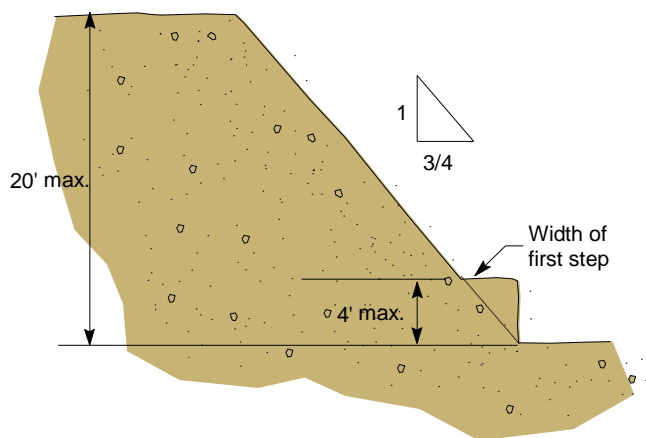

**Figure 7-6. Type A soil, single-bench profile**

**Table 7-5. Maximum dimensions for a single bench in Type A soil**

Maximum total depth	20'
Maximum bench height (vertical rise)	4'
Minimum slope (9" rise to 12" run)	¾:1 H:V
Minimum width of the step for a 4' vertical rise	3'

## 5.2 Multiple benches

Figure 7-7, below, shows a sample multiple-bench excavation.

Only a portion of the first horizontal step is allowed to extend beyond the excavation's maximum permissible slope.

Choose any convenient bench height within the maximum allowable dimensions.

Calculate the required width of the horizontal steps using the bench height and the rules shown in Table 7-6 on page 7-11. Common minimum bench widths based on bench heights are shown in Table 7-7 on page 7-11.

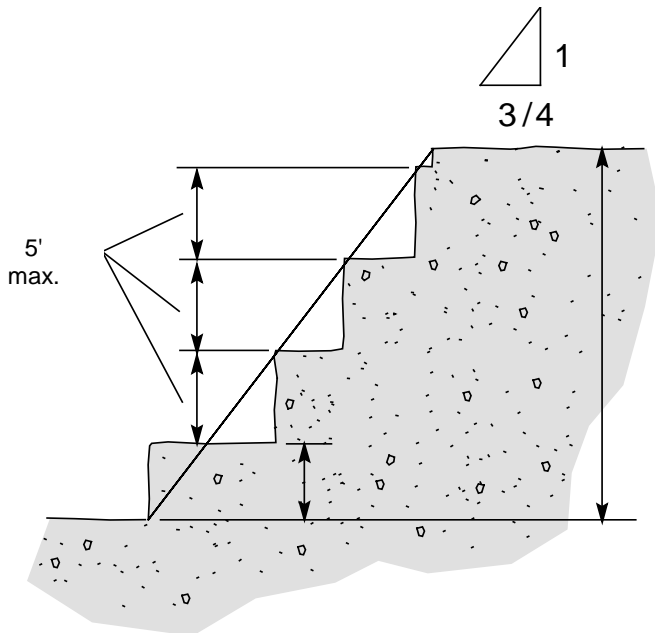

**Figure 7-7. Type A soil, multiple bench excavation**

The **minimum** width of the first bench **must be** based on the height of both the **first and second rises combined**.

**Failure to combine the heights of both of the first two rises to determine the width of the first bench is one of the most common errors made in benching excavations.**

**Table 7-6. Dimensions of multiple benches in Type A soil**

DIMENSION	SIZE
Height of first rise	Any convenient height less than 4'.
Height of remaining rises	Any convenient height less than 5'.
Minimum width of first horizontal step in inches	Add the height of the first rise to the height of the second rise, then multiply by $\frac{3}{4}$ (0.75) for the minimum width of the first horizontal bench. Adding the first two heights to determine the first width always gives a safe bench for Type A soil.
Minimum width of remaining horizontal steps in inches	Multiply the height of the rise by $\frac{3}{4}$ (0.75).

**Table 7-7. Minimum benching widths based on bench heights (Type A soil)**

HEIGHT	MINIMUM WIDTH (HEIGHT x 0.75)
1'	0'9"
2'	1'6"
3'	2'3"
4'	3'
5'	3'9"

THIS PAGE INTENTIONALLY  
LEFT BLANK



## Part 8 Type B Soil

This part discusses requirements, tabular data, and examples for shoring, sloping, and benching in Type B soil.

1

### Characteristics

Several types of soil are classified as Type B.

- Cohesive soil with an unconfined compressive strength greater than 0.5 tons per square foot (TSF), but less than 1.5 TSF.
- Granular cohesionless soil, including angular gravel (similar to crushed rock), silt, silt loam, sandy loam, and, in some cases, silty clay loam and sandy clay loam.
- Soil that meets the unconfined compressive strength or cementation requirements for Type A, but is fissured or subject to vibration.
- Dry rock that is not stable.
- Material that is part of a sloped, layered system where the layers dip into the excavation on a slope less steep than 4:1 H:V, but only if the material would otherwise be classified as Type B.

Previously undisturbed soil is Type B **unless** it would otherwise be classified as Type C.

2

### Hydraulic shoring

#### 2.1 Spacing combinations

Use the vendor's tabulated data or Table 8-1 on page 8-2 to determine the required horizontal spacing for shores.

If raveling or sloughing of the excavation face appears likely, use 4'-wide sheeting (approved plywood or FinnForm) at each vertical shore.

2"-diameter cylinders must have a structural, steel-tube oversleeve 3.5" x 3.5" x 0.1875" extension (installed over the aluminum oversleeve extension) or a steel-tube oversleeve 3" x 3" x 0.1875" extension (installed without the aluminum oversleeve) that extends the full retracted length of the cylinder.



The bottom of the sheeting must extend within 2' of the bottom of the excavation.

IF there is an indication of possible loss of soil from behind the support system,  
THEN the sheeting must extend to the bottom of the excavation.

When working near the end of a trench or excavation, and shoring is required, use end shores or other approved methods to protect employees.

Figure 8-1, below, shows hydraulic shoring for Type B soil.  
Table 8-1, below, gives spacing requirements for shores.

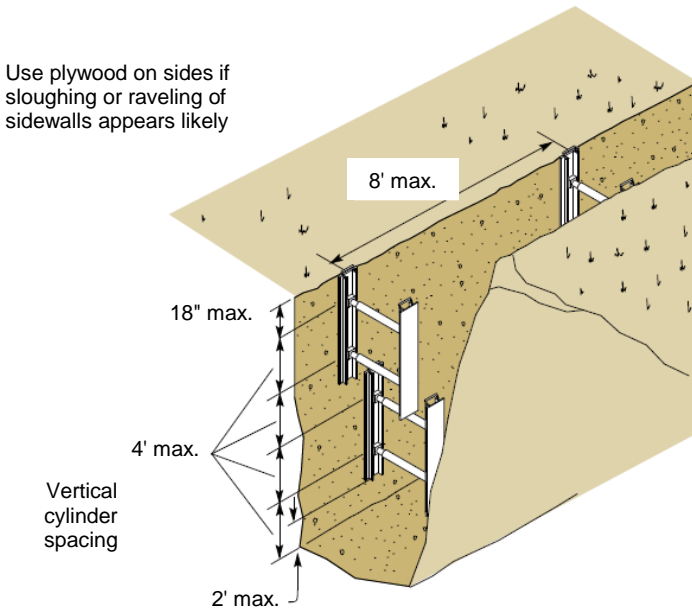

**Figure 8-1. Stacked hydraulic shoring in Type B soil**

**Table 8-1. Type B soil: Cal/OSHA spacing requirements for hydraulic shoring**

DEPTH OF EXCAVATION	MAX. CYLINDER SPACING		MIN. CYLINDER DIAMETER	
	HORIZONTAL	VERTICAL	EXCAVATION 0'-8' WIDE	EXCAVATION 8'-12' WIDE
0-10'	8'	4'	2"	2"
0-15'	6.5'	4'	2"	2"

## 3

## Shoring examples

Figure 8-2, below, shows shoring in Type B soil.

Use plywood on sides if sloughing or raveling of sidewalls appears likely

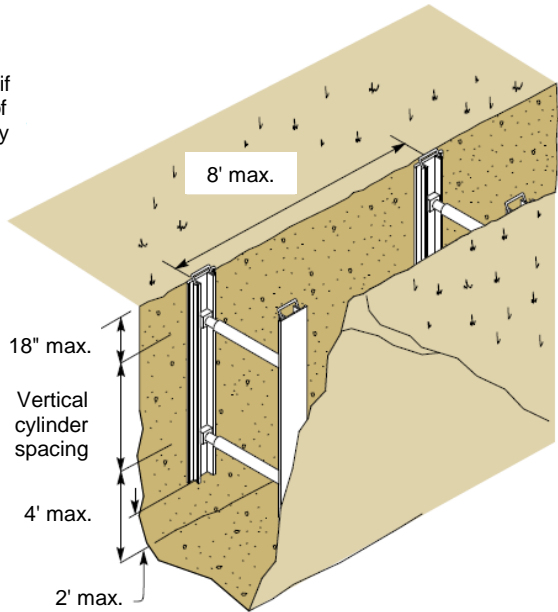

**Figure 8-2. Hydraulic shoring in Type B soil**

### 3.1 Other applications

For excavations that are deeper or wider than those listed above, consult a registered P.E. or use stamped tabulated data.

4

# Waler systems

Figure 8-3, below, shows a sample waler system. Table 8-2 on page 8-5 gives spacing and cylinder diameter requirements for waler systems in Type B soil.

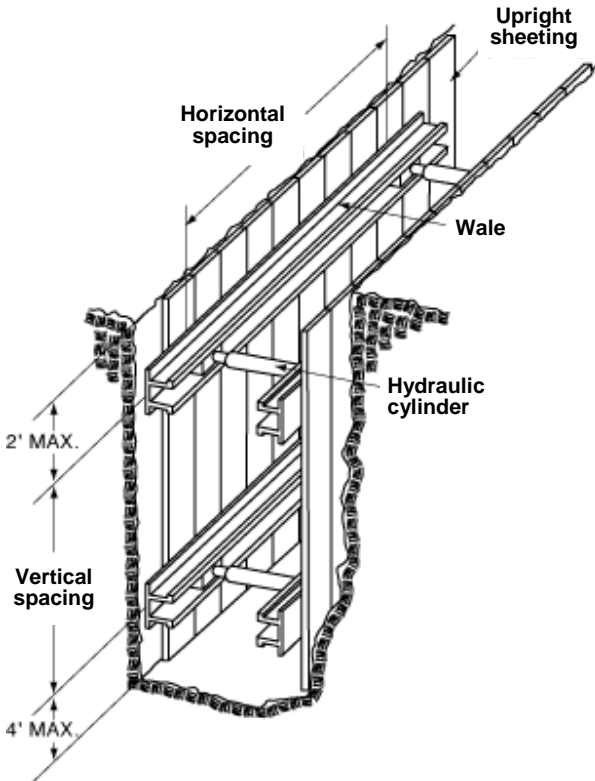

**Figure 8-3. Hydraulic shoring in Type B soil: waler system**

In a trench over 8' wide and up to 12' wide, 2"-diameter cylinders must have structural steel tube oversleeves (3.5" x 3.5" x 0.1875"), or structural oversleeves of manufacturer's specification, extending the full collapsed length.

**Table 8-2. Aluminum hydraulic shoring waler systems, Type B soil**

DEPTH OF TRENCH	WALES		HYDRAULIC CYLINDERS			
	VERTICAL SPACING	SECTION MODULUS (IN <sup>3</sup> ) <sup>a</sup>	TRENCH UP TO 8' WIDE		TRENCH OVER 8' UP TO 12' WIDE	
			HORIZ SPACING	CYLINDER DIAM.	HORIZ SPACING	CYLINDER DIAM.
Over 5' Up to 10'	4'	3.5	8.0	2"	8.0	2"
		7.0	9.0	2"	9.0	2"
		14.0	12.0	3"	12.0	3"
Over 10' Up to 15'	4'	3.5	6.0	2"	6.0	2"
		7.0	8.0	3"	8.0	3"
		14.0	10.0	3"	10.0	3"

**Note for Table 8-2:**

- a. Consult product manufacturer and/or qualified engineer for section modulus of available wales.

For applications other than those listed in the tables, use manufacturer's tabulated data or call a registered P.E. For excavations that are deeper or wider than those listed above, refer to the vendor's tabulated data for the excavation system installed. You may also contact a registered P.E. for assistance. See Part 1, Section 2.1, for phone numbers.

## 5

# Sloping

## 5.1 Slope profile

Sloping is permitted in Type B soil. The slope can be no steeper than 1:1. A profile of the excavation is shown in Figure 8-4, below.

IF an excavation face is sloped at 1:1 H:V

AND shows signs of distress (spalling, raveling, clumps separating),

THEN the wall must be sloped at 1½:1 H:V.

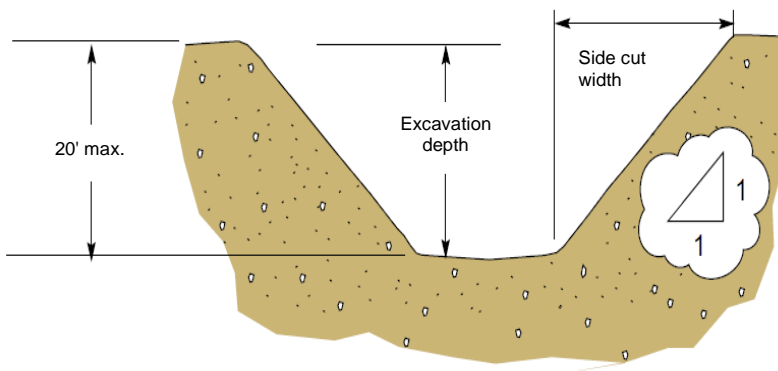

**Figure 8-4. Sloping in Type B soil**

Table 8-3 on page 8-7 contains pre-calculated values for sloping in Type B soil.

**Table 8-3. Sloping dimensions for Type B soil, slope = 1:1**

EXCAVATION DEPTH	SIDE-CUT WIDTH (AT THE TOP OF EACH SIDE CUT, IN FEET)
4'	4'
5'	5'
6'	6'
7'	7'
8'	8'
9'	9'
10'	10'
11'	11'
12'	12'
13'	13'
14'	14'
15'	15'
16'	16'
17'	17'
18'	18'
19'	19'
20'	20'

**Example for Table 8-3:**

Given: Work is being performed in a 12'-deep trench.

Determine: Side cut width.

Data: From Table 8-3, a 12'-deep trench requires a 12' side cut width.

## 5.2 Supported or shielded sloping

Design the shield or shoring system to protect the total depth of the excavation and extend at least 18" above the top of the vertical walls, as shown in Figure 8-5, below.

**NOTE**  
Installing trench shields often requires special lifting equipment due to the heavy weight of the components and the long "reach" needed to place the shield in a sloped trench.

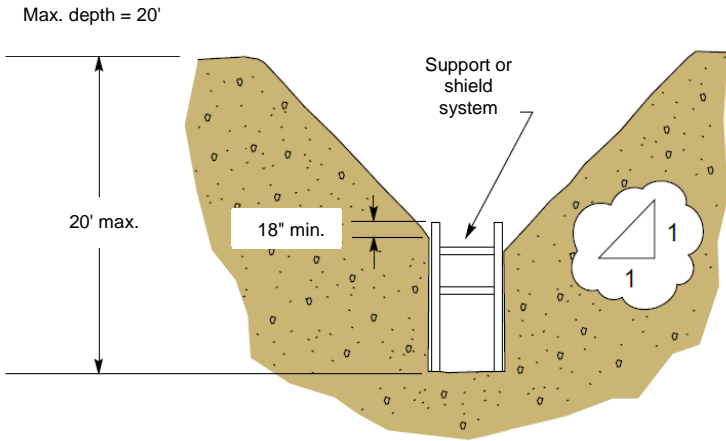

**Figure 8-5. Type B soil: trench shield installed in sloped excavation**

## 6

## Benching

### WARNING

Benching is permitted only in cohesive Type B soil. Do not bench in non-cohesive Type B soil.

### 6.1 Single bench

The simplest form of benching is the single bench, or an excavation having one vertical rise and a horizontal step. Only the benched section may extend beyond the slope of the remaining excavation wall. See Figure 8-6 and Table 8-4, below.

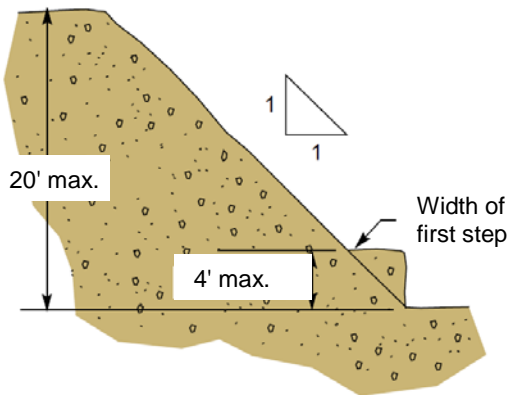

Figure 8-6. Type B cohesive soil, single-bench profile

Table 8-4. Maximum dimensions for a single bench in Type B cohesive soil

DIMENSION	MAXIMUM
Maximum total depth	20'
Maximum height, vertical rise	4'
Minimum slope	1:1
Minimum width of the step (for a 4' vertical rise)	4'

### 6.2 Multiple benches

The slope of a benched excavation must be 1:1 H:V or less (i.e., at least 1' horizontal to 1' vertical). A profile of the excavation is shown in Figure 8-7 on page 8-10. Only a portion of the first horizontal step may extend beyond the excavation's maximum permissible slope.



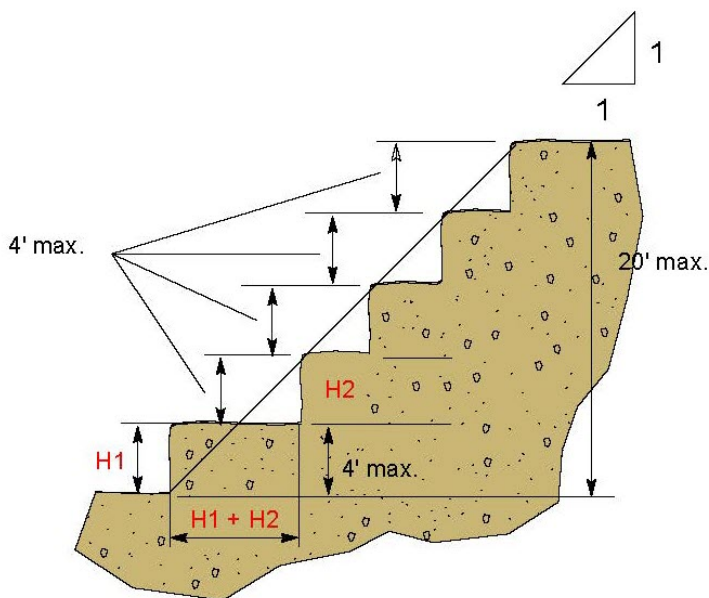

**Figure 8-7. Type B cohesive soil, multiple bench excavation**

### Dimensions of multiple benches

Choose any convenient bench height, within the maximum allowable dimensions. Calculate the required width of the horizontal steps using the bench height and the rules shown in Table 8.5, below.

The width of the first bench **must be** equal to the **total** height of the **first and second** rises **combined**.

**Failure to combine the heights of both of the first two rises to determine the width of the first bench is one of the most common errors made in benching excavations.**

**Table 8-5. Dimensions of multiple benches, Type B cohesive soil**

DIMENSION	SIZES
Height of first rise	Any convenient height up to 4'.
Height of the remaining rises	Any convenient height up to 4'.
Minimum width of first horizontal step	Calculate the width by adding the height of the first rise to the height of the second rise.
Width of the remaining horizontal steps	The minimum width of each step is equal to the height of each vertical rise.



## Part 9 Type C Soil

This part describes requirements, tabular data and examples for shoring and sloping in Type C soil.

Benching is NOT permitted in Type C soil.

### 1

## Characteristics

### WARNING

Type C is a broad classification, and only some Type C soils can be shored using the techniques in this manual. Low-strength Type C soil is a special case and requires assistance from a registered P.E. See Part 1, Section 2.1.

Type C soil is:

- Cohesive soil with an unconfined compressive strength of 0.5 TSF or less
- NOT flowing or submerged

Examples of Type C soil:

- Granular soil
- Submerged rock that is not stable
- Moist cohesive or moist dense granular
- Soil that can be cut near-vertical and stand long enough to allow shoring and sheeting to be properly installed

Type C soil can be shored if:

- It is a moist, cohesive soil OR a moist dense granular soil that does not fit into Type A or B.
- It is not flowing or submerged.
- It can be cut with near-vertical sidewalls and will stand unsupported long enough to properly install a protective system.

## 2

## Hydraulic shoring data

### WARNING

Design the shoring system to protect the total depth of the excavation, even if partially backfilled. **Never enter an unprotected portion of any excavation for any reason.**

### 2.1 Requirements

1. There are no spacing requirements specified in Cal/OSHA code for vertical hydraulic shoring for Type C soil.
2. Vertical hydraulic shores in Type C soil must be specified by a registered P.E. (e.g., stamped tabulated data).
3. Retain tabulated data stamped by a registered P.E. on site.
4. Always use approved sheeting (plywood or FinnForm) with vertical hydraulic shoring in Type C soil.
5. When working with Type C soil, always use plywood or FinnForm sheeting at least 4' wide on excavation sides with engineered vertical shoring, or use a waler system with approved sheeting. See Table 4-2 on page 4-5.
6. Use tabulated data to determine horizontal spacing for shores.
7. When horizontal spacing exceeds 4', monitor open spaces between sheeting to be sure that the excavation face does not slough or ravel.
8. For excavations less than 10' deep, extend the bottom of the sheeting to within 2' of the bottom of the excavation.
9. IF there is an indication of possible soil loss from behind the support system, THEN the sheeting must extend to the bottom of the excavation.
10. For excavations deeper than 10', extend the sheeting to the bottom of the excavation.

11. For 2"-diameter cylinders, install either:
- A structural steel tube oversleeve 3.5" x 3.5" x 0.1875" extension, over the aluminum oversleeve extension

OR

- A steel tube oversleeve 3" x 3" x 0.1875" extension, without the aluminum oversleeve.

The extension must extend the full retracted length of the cylinder.

12. When vertical shores are used, there must be a minimum of three shores spaced equally.
13. When working near the end of a trench or excavation, and shoring is required, use end shores or other approved methods to protect employees.

### 3

## Waler systems

Figure 9-1, below, shows a sample waler system. Table 9-1 on page 9-4 gives spacing and cylinder diameter requirements for waler systems in Type C soil.

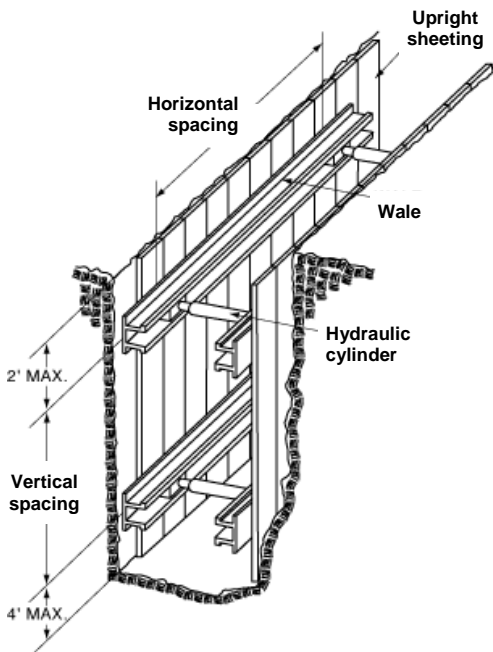

**Figure 9-1. Typical aluminum hydraulic shoring: waler system**

In a trench over 8' wide and up to 12' wide, 2"-diameter cylinders must have structural steel tube oversleeves (3.5" x 3.5" x 0.1875"), or structural oversleeves of manufacturer's specification, extending the full collapsed length.

**Table 9-1. Aluminum hydraulic shoring - waler systems, Type C soil**

DEPTH OF TRENCH	WALES		HYDRAULIC CYLINDERS			
	VERTICAL SPACING	SECTION MODULUS (IN <sup>3</sup> ) <sup>a</sup>	TRENCH UP TO 8' WIDE		TRENCH OVER 8' UP TO 12' WIDE	
			HORIZ SPACING	CYLINDER DIAM.	HORIZ SPACING	CYLINDER DIAM.
Over 5' Less than 10'	4'	3.5	6.0'	2"	6.0'	2"
		7.0	6.5'	2"	6.5'	2"
		14.0	10.0'	3"	10.0'	3"
10' to 15'	4'	3.5	4.0'	2"	4.0'	2"
		7.0	5.5'	3"	5.5'	3"
		14.0	8.0'	3"	8.0'	3"

**Notes for Table 9-1:**

- Consult product manufacturer and/or qualified engineer for section modulus of available wales.
- For applications other than those listed in the tables, use manufacturer's tabulated data or call a registered P.E.

### 3.1 Other applications

For excavations that are deeper or wider than those listed above, consult a registered P.E. or use stamped tabulated data.

## 4

## Sloping

### 4.1 Profile of slope

Sloping is permitted in Type C soil. The slope must be no steeper than 1½:1 H:V.

IF an excavation face is sloped at 1½:1 H:V, AND shows signs of distress (spalling, raveling, clumps separating),

THEN the wall must be sloped to 2:1 H:V.

Figure 9-2, below, shows sloping in Type C soil. Table 9-2, below, gives side cut widths for specific excavation depths.

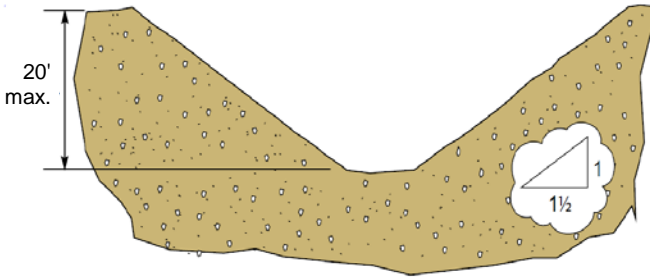

**Figure 9-2. Sloping in Type C soil**

**Table 9-2. Sloping dimensions for Type C soil, 1½:1 H:V**

EXCAVATION DEPTH	SIDE CUT WIDTH
4'	6'0"
5'	7'6"
6'	9'0"
7'	10'6"
8'	12'0"
9'	13'6"
10'	15'0"
11'	16'6"
12'	18'0"
13'	19'6"
14'	21'0"
15'	22'6"
16'	24'0"
17'	25'6"
18'	27'0"
19'	28'6"
20'	30'0"

**Example for Table 9-2**

Given: Work is being performed in a 12'-deep trench.

Determine: Side cut width.

From Table 9-2: A 12'-deep trench requires a minimum 18' side cut width.

## 4.2 Supported or shielded sloping

Figure 9-3, below, shows dimensions for supported or shielded sloping in Type C soil. In the figure, the total depth is 20'.

**WARNING**

Design shield or shoring systems to protect employees the total depth of the excavation plus at least 18" above the top of the vertical walls. Never enter an unprotected portion of any excavation for any reason.

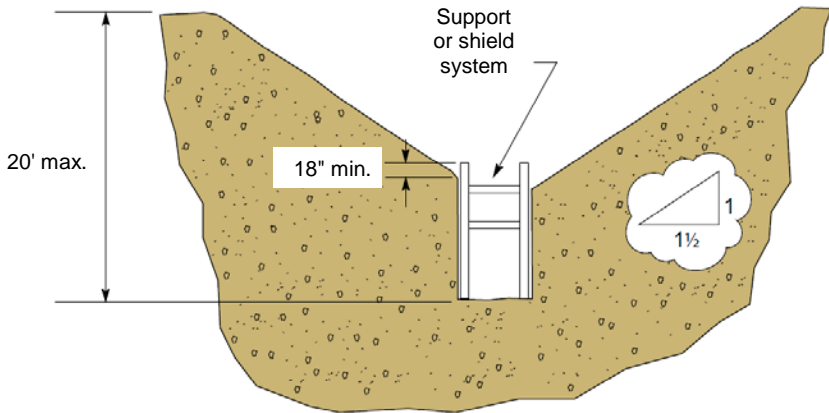

**Figure 9-3. Type C soil: trench shield installed in sloped excavation**



## Part 10

# Sloping Layered Soil

Parts 7, 8 and 9 list requirements for and provide examples of sloping types A, B and C soils. This part outlines requirements for and provides examples of sloping excavations with layered soil types.

1

## About sloping layered soil

Layered soils may be sloped. When planning such sloping, it is important to consider the following:

- A slope must NOT become steeper towards the top if the soil type changes. For example, if type A or B is above type C, you must use the weaker classification (type C) for the entire slope.

See Part 2, Section 5.7, for layered soil conditions.



## 1.1 Layered soil: Type A over Type B

Use the slope of the Type B component for the entire excavation. Figure 10-1 and Table 10-1 show sloping for Type A over Type B.

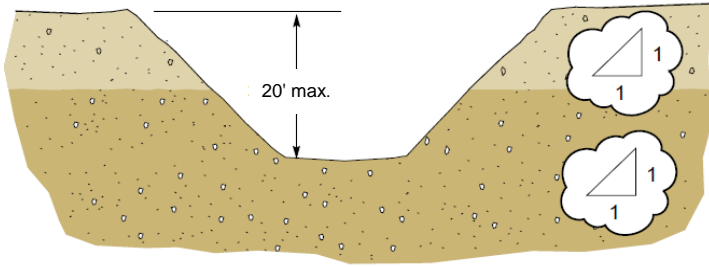

**Figure 10-1. Sloping profile: Type A over Type B**

**Table 10-1. Sloping dimensions: Type A over Type B**

DEPTH	COMBINED SETBACK: BOTH TYPES (1:1 H:V)
1'	1'0"
2'	2'0"
3'	3'0"
4'	4'0"
5'	5'0"
6'	6'0"
7'	7'0"
8'	8'0"
9'	9'0"
10'	10'0"
11'	11'0"
12'	12'0"
13'	13'0"
14'	14'0"
15'	15'0"
16'	16'0"
17'	17'0"
18'	18'0"
19'	19'0"
20'	20'0"

## 1.2 Layered soil: Type A over Type C

Use the slope of Type C soil for the entire excavation. When the least-stable soil is on the bottom, use the slope of the least-stable soil for the entire excavation. Figure 10-2 and Table 10-2 show sloping for Type A over Type C.

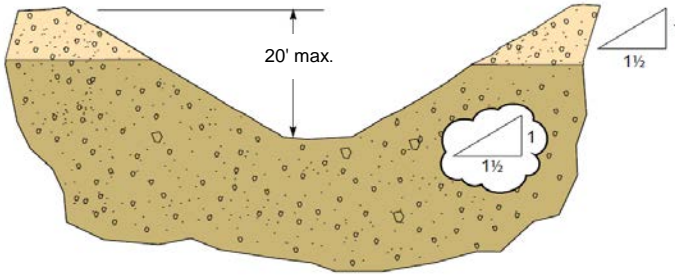

Figure 10-2. Sloping profile: Type A over Type C

Table 10-2. Sloping dimensions: Type A over Type C

DEPTH	COMBINED SETBACK: BOTH TYPES (1½:1 H:V)
1'	1'6"
2'	3'0"
3'	4'6"
4'	6'0"
5'	7'6"
6'	9'0"
7'	10'6"
8'	12'0"
9'	13'6"
10'	15'0"
11'	16'6"
12'	18'0"
13'	19'6"
14'	21'0"
15'	22'6"
16'	24'0"
17'	25'6"
18'	27'0"
19'	28'6"
20'	30'0"

### 1.3 Layered soil: Type B over Type A

Use the slope of the Type B component for the entire excavation. Figure 10-3 and Table 10-3 show sloping for Type B over Type A.

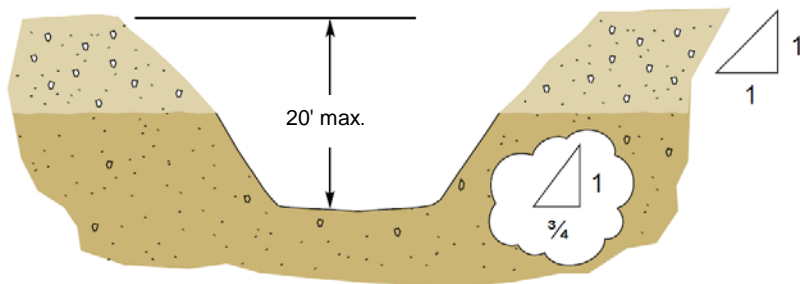

Figure 10-3. Sloping profile: Type B over Type A

Table 10-3. Sloping dimensions: Type B over Type A

DEPTH	SETBACK	
	TYPE B (1:1 H:V)	TYPE A (¾:1 H:V)
1'	1'0"	0'9"
2'	2'0"	1'6"
3'	3'0"	2'3"
4'	4'0"	3'0"
5'	5'0"	3'9"
6'	6'0"	4'6"
7'	7'0"	5'3"
8'	8'0"	6'0"
9'	9'0"	6'9"
10'	10'0"	7'6"
11'	11'0"	8'3"
12'	12'0"	9'0"
13'	13'0"	9'9"
14'	14'0"	10'6"
15'	15'0"	11'3"
16'	16'0"	12'0"
17'	17'0"	12'9"
18'	18'0"	13'6"
19'	19'0"	14'3"
20'	20'0"	15'0"

## 1.4 Layered soil: Type B over Type C

Use the slope of Type C soil for the entire excavation. When the least-stable soil is on the bottom, use the slope of the least-stable soil for the entire excavation. Figure 10-4 and Table 10-4 show sloping for Type A over Type B.

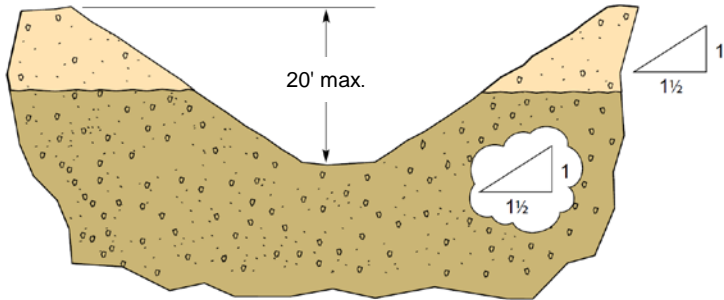

Figure 10-4. Sloping profile: Type B over Type C

Table 10-4. Sloping dimensions: Type B over Type C

DEPTH	COMBINED SETBACK: BOTH TYPES (1½:1 H:V)
1'	1'6"
2'	3'0"
3'	4'6"
4'	6'0"
5'	7'6"
6'	9'0"
7'	10'6"
8'	12'0"
9'	13'6"
10'	15'0"
11'	16'6"
12'	18'0"
13'	19'6"
14'	21'0"
15'	22'6"
16'	24'0"
17'	25'6"
18'	27'0"
19'	28'6"
20'	30'0"

## 1.5 Layered soil: Type C over Type A

Figure 10-5 and Table 10-5 show sloping for Type C over Type A.

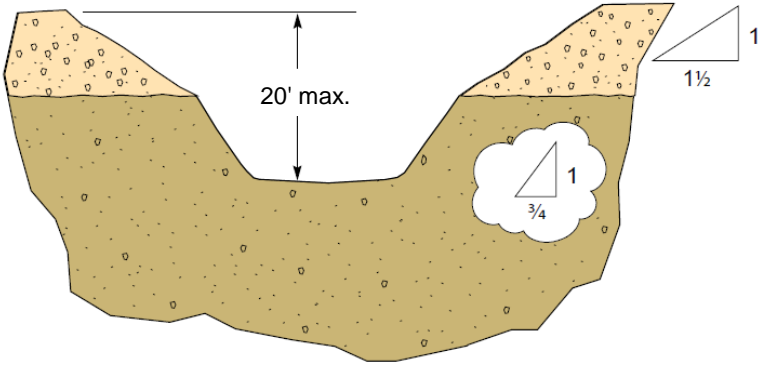

Figure 10-5. Sloping profile: Type C over Type A

Table 10-5. Sloping dimensions: Type C over Type A

DEPTH	SETBACK	
	TYPE C (1½:1 H:V)	TYPE A (¾:1 H:V)
1'	1'6"	0'9"
2'	3'0"	1'6"
3'	4'6"	2'3"
4'	6'0"	3'0"
5'	7'6"	3'9"
6'	9'0"	4'6"
7'	10'6"	5'3"
8'	12'0"	6'0"
9'	13'6"	6'9"
10'	15'0"	7'6"
11'	16'6"	8'3"
12'	18'0"	9'0"
13'	19'6"	9'9"
14'	21'0"	10'6"
15'	22'6"	11'3"
16'	24'0"	12'0"
17'	25'6"	12'9"
18'	27'0"	13'6"
19'	28'6"	14'3"
20'	30'0"	15'0"

## 1.6 Layered soil: Type C over Type B

Figure 10-6 and Table 10-6 show sloping for Type C over Type B.

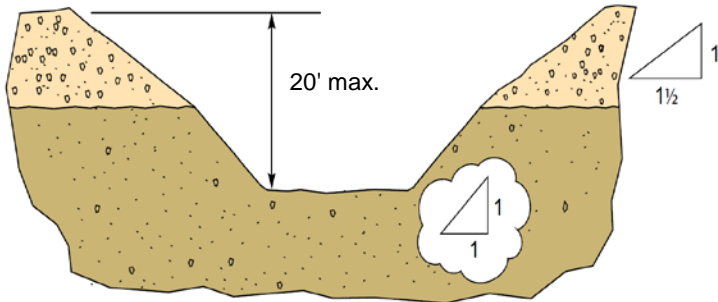

**Figure 10-6. Sloping Profile: Type C over Type B**

**Table 10-6. Sloping Dimensions: Type C over Type B**

DEPTH	SETBACK	
	TYPE C (1½:1 H:V)	TYPE B (1:1)
1'	1'6"	1'0"
2'	3'0"	2'0"
3'	4'6"	3'0"
4'	6'0"	4'0"
5'	7'6"	5'0"
6'	9'0"	6'0"
7'	10'6"	7'0"
8'	12'0"	8'0"
9'	13'6"	9'0"
10'	15'0"	10'0"
11'	16'6"	11'0"
12'	18'0"	12'0"
13'	19'6"	13'0"
14'	21'0"	14'0"
15'	22'6"	15'0"
16'	24'0"	16'0"
17'	25'6"	17'0"
18'	27'0"	18'0"
19'	28'6"	19'0"
20'	30'0"	20'0"

THIS PAGE INTENTIONALLY  
LEFT BLANK



# Part 11

## Frequently Asked Questions

TD-4621M, Rev. 1  
 Publication Date: 7/23/2014  
 Effective Date: 1/1/2015

### 1

## Resource information

QUESTION	ANSWER
1. Does this manual need to be at the job site?	Yes. This manual must be in the vicinity of the job site. See the Preface.
2. If you have a laptop in your truck, does this count as a manual?	No. Because OSHA requires the information to be on site, and due to battery and accessibility issues with having the manual on a laptop, personnel must have the physical book on site with them.
3. Whom can I call for assistance with excavation problems?	See the key contacts in Part 1, Section 2.1.
4. When do I call a registered P.E. for advice or use stamped tabulated data?	<p>For any of the following reasons:</p> <ul style="list-style-type: none"> <li>▪ If soils are special, loose or flowing (Part 2, Section 5), e.g., very soft clay, saturated sand, peaty soil, rubble rock.</li> <li>▪ Excavating across a slope steeper than 3:1 H:V. (Part 2, Section 5.5)</li> <li>▪ Adjacent slope nearby (Part 2, Section 5.6) AND either:               <ul style="list-style-type: none"> <li>• The toe (base) of a slope that has an angle steeper than 3:1 H:V is located closer to the excavation than the proposed depth of the excavation</li> <li>or</li> <li>• The toe of a slope with an angle less than 3:1 H:V is closer to the excavation than ½ the proposed excavation depth AND the proposed depth is greater than 10'.</li> </ul> </li> <li>▪ If large vehicles will travel close to the excavation walls or if large or heavy spoil piles will be placed close to the excavation. (Part 2, Section 5.8)</li> </ul>



QUESTION	ANSWER
(4., continued)	<ul style="list-style-type: none"> <li>▪ Excavating near structures or foundations, if you are concerned about building loading on the trench sidewall. (Part 2, Section 5.8)</li> <li>▪ Design of structural ramps. (Part 3, Section 2.1)</li> <li>▪ Assistance with water removal or evaluation of an excavation damaged by water. (Part 3, Section 2.1, and Appendix E)</li> <li>▪ Approval of alternative sheeting. (Part 4, Section 2.3)</li> <li>▪ Design of hydraulic shoring systems greater than 15' deep or 12' wide. (Parts 7, 8, and 9)</li> <li>▪ Design of protective systems in low-strength Class C soil that cannot hold a vertical side long enough to install shoring. (Part 9)</li> <li>▪ Design of shield or shoring box protective system used in excavations over 20' deep.</li> <li>▪ Evaluating feasibility of bracing the shoring against the foundation of a building.</li> <li>▪ Tunneling under a curb, sidewalk, or pavement.</li> <li>▪ Design of a timber-shoring installation.</li> </ul>
5. The <i>Excavation Safety Manual</i> does not show excavations wider than 12'. What do we do for wider excavations?	Call a registered Professional Engineer (P.E.) for advice or use stamped tabulated data.
6. What is covered by the <i>Excavation Safety Manual</i> ?	<p>Excavations that are protected as follows are covered by the methods contained in the <i>Excavation Safety Manual</i>:</p> <ul style="list-style-type: none"> <li>▪ Hydraulic shoring, waler or shielding systems up to and including 15' deep.</li> <li>▪ Sloping or benching systems up to and including 20' deep.</li> </ul> <p>Methods of tunneling or undermining are not covered.</p>

## 2

## Creating the excavation

QUESTION	ANSWER
<p>7. As the backhoe is digging, is it OK to help clear the trench?</p>	<p>Never enter an excavation while a backhoe is digging.</p> <p>If <b>all</b> the following conditions are met, it is acceptable to enter the trench:</p> <ul style="list-style-type: none"> <li>▪ Trench is less than 5' deep.</li> <li>▪ The Competent Person has designated the excavation safe for entry.</li> <li>▪ The backhoe is not digging when the worker is in the excavation.</li> <li>▪ There is no hazardous atmosphere.</li> </ul> <p>Deeper trenches require employees to install shoring or protection before assisting with excavation clean-out.</p>
<p>8. How do I dispose of the water that enters the excavation?</p>	<p>Disposing of water that accumulates in excavations is becoming more difficult. Federal, state, and local laws govern the discharge of water from the worksite. Consult with local environmental representatives in your area about the specific situation prior to discharge of any accumulated water from a worksite or excavation. Contact your local environmental field specialist (EFS) or Safety Department; see Part 1, Section 2.1. See also Appendix E, Section 2.</p>
<p>9. Does the <i>Excavation Safety Manual</i> allow tunneling under a curb?</p>	<p>No. Neither tunneling nor undermining is covered in the <i>Excavation Safety Manual</i>. This work is a special case and requires consultation with a registered P.E. Contact the Company Geosciences department for assistance. See Part 1, Section 2.1.</p>

## 3

## Competent Person

QUESTION	ANSWER
10. After attending an excavation safety class, am I considered a "Competent Person?"	No, formal training is only one component of being considered as a Competent Person. You must also pass an accepted competency test, be proficient in soil classification and selecting protective systems, and be designated as a Competent Person. See Part 2, Section 1.1.
11. I attended vendor-provided excavation safety training and have a certificate stating I am a Competent Person. Does that training meet all the Company criteria for becoming a Competent Person?	No, vendor training alone is not sufficient to meet Company requirements. See Question 10 answer, above.
12. I've been through the Competent Person training; however, I don't feel comfortable being the person on site making these decisions. Do I have to act as a Competent Person?	No. Discuss with your supervisor your concerns and desire for additional training to ensure you can become competent. It is important for all crew personnel to understand excavation safety and be aware of changing conditions that may introduce hazards.
13. Many employees have been trained as Competent Persons – who is the Competent Person?	There is only one Competent Person in charge per excavation.  The Competent Person for the excavation is designated by the supervisor or person in charge. Many employees have been trained so that each is knowledgeable about the hazards and aware of changing conditions. If you notice a hazard or changed condition, bring it to the attention of the designated Competent Person.

## 4

## Soils and soil classification

QUESTION	ANSWER
14. What happened to C-60 and C-80 soil classifications?	The Company adopted the Cal/OSHA soil classification system, which has only one type of C soil. References to a lower-strength C soil are similar to the old C-80 classification.
15. How many tests must I perform to classify a soil sample?	You must perform at least two tests for each sample. You must perform one visual test and one manual test. If there are several soil types in the excavation, you must test each type and then select your excavation safety system based on the weakest soil.
16. Why is Type A soil in the manual?	Type A is in the manual for those rare conditions when you may be excavating in or near stable rock.  Realistically, any soil that classifies initially as A soil, unless it is stable rock, will likely downgrade to B soil with exposure to atmospheric conditions.  Always think twice before classifying soil as type A.
17. Can we use a pocket penetrometer to classify soil type?	Yes. This is the most accurate way to classify unconfined compressive strength of cohesive soils. It is a good idea to take tests on a few soil samples from the same part of the excavation. Type A soil reads at least 1.5 tons per square foot (TSF), but a soil cannot be classified as Type A if it has been disturbed. Type B reads between 1.5 TSF and 0.5 TSF. All soils less than 0.5 TSF are Type C.

## 5

## Benching and sloping

QUESTION	ANSWER
18. When is benching permitted?	The Company and Cal/OSHA permit benching only in Type A soil and in Type B cohesive soil. Double-check your soil classification before choosing to bench. See Parts 7 and 8 for specifics on benching.
19. I have a benched excavation. The bottom bench width is not equal to the height of the first two steps added together. Why do I have to make it wider?	The first bench must be wide enough to achieve the required slope for the soil type.
20. Can I make the bottom bench wider than the first two steps added together?	Yes, you can. Keep in mind that this will make the excavation larger.
21. I'm in a 4'-deep part of an excavation that extends to 5' deep at the deepest part. I'm OK to work without a protective system, right?	No. The excavation is measured at the deepest part of the excavation to determine depth. If any part of the excavation is 5' deep or greater, a protective system must be installed if workers are to enter any part of the excavation.

## 6

## Shoring and protective systems

### 6.1 What to use and when

QUESTION	ANSWER
22. When do we need shoring?	If you plan to enter the excavation, and any part is 5' deep or deeper, or there is a chance of a cave-in, the excavation must be shored or protected on all sides.
23. The excavation is more than 5' deep, but I will only be in it for a minute or two. Do I need to install shoring?	Yes. You must use shoring or some other protective method if anyone will be in the excavation at any time. The conditions or circumstances that establish the need for shoring do not include time.

**Shoring and protective systems: What to use and when, cont.**

QUESTION	ANSWER
<p>24. When do I need to shore or use other protective methods?</p>	<p>Shoring, benching, shielding, or sloping is always required under any of the following conditions:</p> <ul style="list-style-type: none"> <li>■ The sides of the excavation are unstable and the work cannot be performed safely. This includes excavations that are less than 5' deep everywhere.</li> <li>■ The excavation is at least 5' deep, and someone will enter the excavation.</li> </ul> <p>Shoring, benching, or sloping may be required if:</p> <ul style="list-style-type: none"> <li>■ There is vibration in the excavation area.</li> <li>■ There are heavy loads or vehicles near the excavation.</li> <li>■ Other environmental factors decrease the soil stability.</li> </ul>
<p>25. If I dig an excavation 5½' deep, and I backfill to 4' deep, am I OK without shoring?</p>	<p>No. For the purposes of protection, the excavation must be considered 5½' deep, because the backfill is not compacted and there is no way to compact it without shoring the excavation.</p>
<p>26. The ground around the excavation is uneven. It looks like the excavation, for the most part, is less than 5' deep. Employees will work in the excavation. Must I measure the depth? Where?</p>	<p>Because employees will be in the excavation, you must be sure it is less than 5' deep before you choose not to use shoring. Measure the excavation at the deepest point and determine shoring requirements based on that measurement. Remember that if risk factors indicate a cave-in is possible, you must shore even if the excavation is less than 5' deep. See Part 2, Section 1.2.</p>

**Shoring and protective systems: What to use and when, cont.**

QUESTION	ANSWER
27. Can we use air jacks (shores) on the job?	<p>Air jacks and other shoring systems designed by a registered P.E. may be used if the following statements are true:</p> <ul style="list-style-type: none"> <li>▪ A Company management person approves the use of the air jacks.</li> <li>▪ The employee using the air jacks is trained and knowledgeable on their installation and use.</li> <li>▪ The shores are inspected and maintained according to the manufacturer's requirements.</li> <li>▪ The shores are installed as specified in the manufacturer's tabulated data.</li> </ul>
28. Do I need to protect an entire excavation?	<p>Perhaps. If the soil appears unstable and a cave-in is possible, you must shore all areas that appear to be at risk. If the soil appears to be stable, then protection is required only in the areas where employees will be working or entering and exiting the excavation.</p> <p>When protecting only a section of an excavation, consider all phases of the work that will be performed inside the excavation. Anticipate where employees must go to enter and exit, position materials, and work. If you do not choose to shore or protect the entire excavation, barricade the "no entry" zone and tailboard the barricade often during the day. Do not enter this zone for any reason.</p> <p>Remember the basic rule of shoring: "If there is an unsafe spot in the excavation, someone will find a reason to stand there."</p>
29. Do we have to shore all four sides?	<p>If you plan to enter the excavation, and it is 5' deep or deeper, or there is a chance of a cave-in, the excavation must be shored or protected on all sides. An unprotected area of the excavation can be identified and barricaded to prevent entry.</p>
30. Can we use shoring and benching, or do I have to bench everything?	<p>Any combination of approved methods for the soil type can be used to protect the worker entering the excavation.</p>

## 6.2 Sheeting

QUESTION	ANSWER
31. Is plywood required for shoring?	For loose Type B and Type C soil, yes. For other soils, it is required if spalling or raveling is occurring. FinnForm and Euroform are alternatives to plywood for use as sheeting. See Part 4, Section 2.3.
32. Can holes be cut in the plywood?	To maintain the structural integrity of the plywood, keep the number of holes to a minimum. Plywood may be cut to clear the substructures. In this case, do not re-use it; recycle it instead.  Small holes can be drilled in the plywood to attach lifting or guidance lines. These attachments must be inspected periodically to ensure the sheet is structurally sound.
33. How do we inspect the plywood to ensure it's OK for use as sheeting? When do we need to replace the plywood?	Plywood is OK to reuse if it does not appear to be damaged. Recycle plywood with obvious cracks or large holes in the sheet. Recycle plywood if it is bowed or does not lay flat against the excavation side wall.
34. How do I lift the plywood that was used for sheeting out of the excavation?	A small hole can be drilled in the plywood and ropes attached to facilitate lifting of the plywood. Plywood can be lifted using the backhoe bucket.

## 6.3 Installation

QUESTION	ANSWER
35. Can I pump a hydraulic cylinder under the green zone to avoid damaging the surrounding material?	No. The shoring is not properly installed if the cylinders are not pressurized to the green zone. If the excavation walls cannot withstand the necessary pressure, choose an alternate protective method, such as a shield or shoring box.
36. Where do I find the standards for public crossings?	Contact your local city offices for their standards. See Appendix C.  <b>NOTE: Verify that this crossing is acceptable locally before building or using a crossing with these dimensions.</b>
37. Can I brace my shoring up against the foundation of a building?	Only if a registered P.E. determines that the foundation of the building can hold the pressure of the shores pressing against it. See Part 2, Section 5.8 for more information.



**Shoring and protective systems: Installation, cont.**

QUESTION	ANSWER
38. I have to shore up against or very near other utilities—what is the procedure? What precautions do I need to take? Do we need to talk to other utilities in case they have to take precautions?	Notify the existing utility either directly or through the 811 system that you are excavating near their facilities and will be installing shoring very close to those facilities. Take care to protect third-party facilities during the shoring installation.
39. If there is plenty of room around a shield (cage) when it is installed in the excavation, can we use shoring to prevent the shield from shifting or must we backfill around the shield?	Backfilling to $\frac{1}{2}$ to $\frac{2}{3}$ of the height of the shield is an industry best practice. See Part 4, Section 3.
40. How do we test the hydraulic shoring each day?	Connect the hydraulic pump and verify pressure in each cylinder daily to verify that the pressure is in the green zone.
41. Can we use a backhoe to assist in removal of shoring?	After the pressure has been released and the shoring has been folded, it is permissible to use any available mechanical lifting equipment to remove the shoring.
42. Can hydraulic shoring be installed as an end shore, using a steel plate across the trench end?	No, unless tabulated data supports the lateral loading on the cylinder.
43. Can we combine any of these protective methods? How?	Yes, any methods can be used in combination. Each system must follow the tabulated data requirements for the system. Common uses are: <ul style="list-style-type: none"> <li>▪ End shores with hydraulic shoring or walers</li> <li>▪ Shields or shoring boxes with sloping or benching</li> </ul>
44. Can I install shoring jacks in the steel boxes – against a strut or foundation?	Do not brace shoring against a shield or box strut unless there is tabulated data to support the use of the shoring in this manner and a registered P.E. has reviewed the work.

**Shoring and protective systems: Installation, cont.**

QUESTION	ANSWER
45. Can I use a double-ram shore as an end shore (i.e., applying force laterally to a hydraulic ram, either with or without a steel plate or plywood)?	No, unless the tabulated data supports this use.
46. I have to move some shoring supports around to get the pipe in the excavation—what are the precautions and rules about this?	<ul style="list-style-type: none"> <li>▪ All personnel shall be out of the excavation when supports are removed.</li> <li>▪ Lower the pipe into the excavation using tag lines, then reinstall shoring.</li> <li>▪ Personnel are allowed to re-enter the excavation once the Competent Person has inspected and given approval.</li> </ul>

**6.4 Shoring maintenance**

QUESTION	ANSWER
47. How do I determine if the shoring is damaged or cannot be used?	Inspect visually. Identify any cracks, misalignment, damaged cylinders, or suspected damage. Do not use any section or component that does not appear in good condition.
48. I'm rebuilding shoring. What are the testing requirements?	Contract the work to a qualified shoring vendor who can classify the shoring, provide tabulated data for it, and make any needed repairs.
49. What do I do with damaged shoring?	Contact the vendor that provided the shoring. Damaged shoring must be repaired by the vendor or manufacturer's designated representative and verified by a registered P.E. <b>before</b> being returned to service.

## 7

## Excavation security

QUESTION	ANSWER
50. If an excavation is outside of a traffic area, such as in a field or a sidewalk, how should the area be secured from the public?	<b>It is critical that excavations are secure.</b> When the public is exposed to excavations in non-traffic areas, the excavations must be either backfilled or covered with steel plates. Installation of cyclone fencing is also recommended to secure the area. If it is impossible to use a steel plate, obtain permission from your supervisor to use plywood. It must be secure so that no unauthorized people can access the excavation.
51. Is plywood acceptable to cover excavations or sidewalks when the crew is not there?	Secure excavations outside of trafficked areas with steel plates and cyclone fencing to prevent access. See question 50.

## 8

## Cal/OSHA

QUESTION	ANSWER
52. Can Cal/OSHA cite the Company if I am in an unshored trench that is less than 5' deep?	Yes. If the inspector believes the sides of the excavation are unstable, the Company may be cited. If there is a cave-in and someone is injured, a citation is even more likely.
53. I have heard that Cal/OSHA regulations do not apply to owners of companies. Does that mean that a Company supervisor is exempt from the rules in the <i>Excavation Safety Manual</i> ?	No. Compliance with Cal/OSHA and the <i>Excavation Safety Manual</i> is mandatory for all employees.
54. What should I do if an OSHA inspector shows up on the jobsite?	See Appendix B.

## 9

## Controlling hazards

QUESTION	ANSWER
55. Is the fluid used in hydraulic shoring dangerous?	There may be hazards associated with some of the hydraulic shoring fluids now in use. Read the Safety Data Sheet (SDS) for information about the particular hydraulic shoring fluid you are using. When required, wear appropriate personal protective equipment (PPE) when exposed to hydraulic shoring fluid. Always follow the manufacturer's recommended procedures for containing and cleaning up leaks and spills.
56. When do I specifically need to test the air in an excavation?	Where a hazardous atmosphere exists or could reasonably be expected to exist. See Part 3, Section 2.1, and Safety Procedure SHC 232, Attachment 5, "Entry into Excavations."  <b>NOTE: Not all excavations qualify as a "confined space."</b>
57. I occasionally have multiple bell holes on the same jobsite. Do I have to test each bell hole?	See the answer to Question 56, above. Different situations require different levels of testing.

THIS PAGE INTENTIONALLY  
LEFT BLANK



## Appendix A Soil Mechanics

### 1

## Earth Pressures

An understanding of earth pressures supports an understanding of the need for shoring to ensure safety. The amount of earth pressure exerted upon the side wall of any excavation depends on the weight and depth of the soil that it supports.

Earth pressure is based on:

- Type of soil
- Depth of excavation
- Moisture conditions

An example of earth pressure distribution is shown in Figure A-1, below.

The center of the earth pressures (as estimated in Figure A-2 on page A-2) is normally found between  $\frac{1}{2}$  and  $\frac{2}{3}$  of the depth of a simple excavation. However, additional earth pressures result from surface encumbrances or loading and differences in soil layer cohesiveness. These additional pressures influence the actual center of pressure at an excavation site.

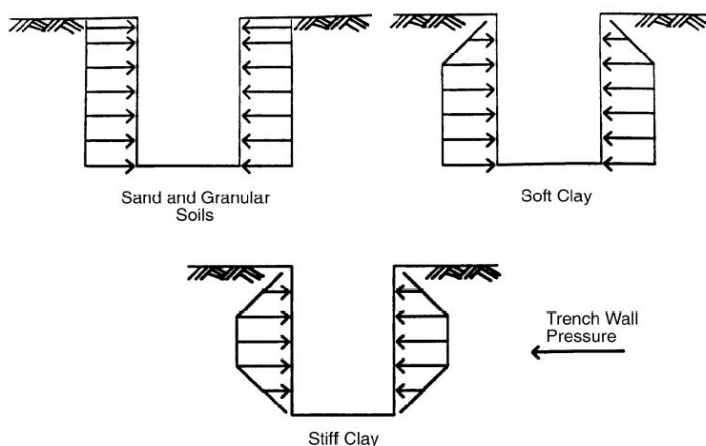

**Figure A-1. Pressure distributions on the side walls of an excavation**

Lateral forces from soil are transferred onto the side walls of an excavation. As a general rule, the center of pressure is at a lower depth when cohesion is poor (as in fresh fill dirt, water-bearing sand, or loose ground). Where cohesion is high, the center of pressure is higher (as in good compact soil).

The location of the center of pressure can change after a cut is made, unless support is provided to prevent earth movement.

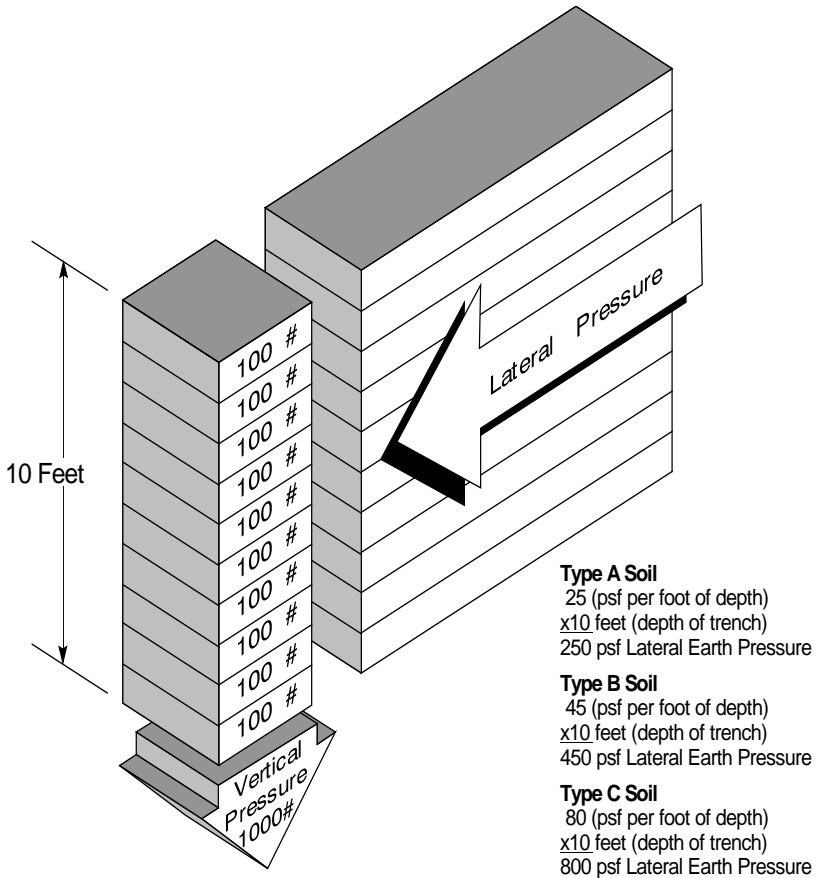

**Figure A-2. Lateral pressure**

Regardless of the soil type, as the depth of the trench increases, the magnitude of pressures on the full height of the excavation also increases. The presence of ground water adds hydrostatic (water) pressure against the walls of the trench, as shown in Figure A-3 on page A-3.

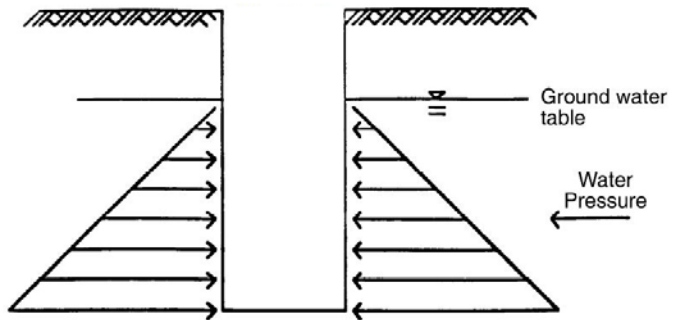

**Figure A-3. Added effect of water pressure**

Water reduces cementation and friction bonding of individual soil particles, which then tend to float apart. This increases the weight of the soil and can overpower the soil's strength, so that it acts more like water than soil.

Consider the effect of moisture on clay. When dry, clay weighs approximately 65 pounds per cubic foot. Because of clay's absorptive properties, it nearly doubles its weight when saturated. Clay also becomes slick and fluid.

Water negatively affects the stability of other soil types as well, because of the increase in weight and fluidity.

## 2

## Trench stress and failure

Stresses and deformations can occur in an open cut or trench. For example, increases or decreases in moisture content can reduce the stability of a trench or excavation. The following diagrams show some of the more frequently identified causes of trench failure.

Tension cracks usually form at a horizontal distance of 0.5 to 0.75 times the depth of the trench, measured from the top of the vertical face of the trench. See Figure A-4, below, for additional details.

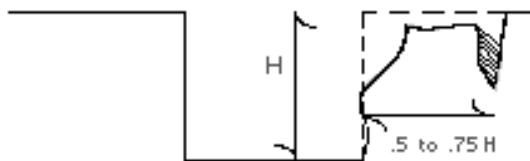

**Figure A-4. Tension cracks**



## 2.1 Sliding or sloughing

Sliding or sloughing may result from tension cracks, as shown in Figure A-5.

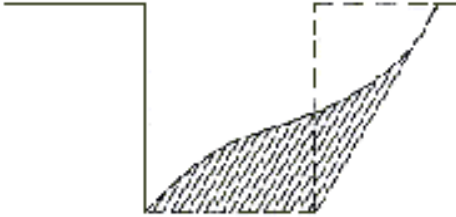

Figure A-5. Sliding

## 2.2 Toppling

In addition to sliding, tension cracks can cause toppling. Toppling occurs when the trench's vertical face shears along the tension crack line and topples into the excavation, as shown in Figure A-6.

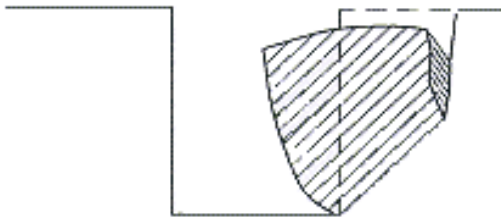

Figure A-6. Toppling

## 2.3 Subsidence and bulging

An unsupported excavation can create an unbalanced stress in the soil, which, in turn, causes subsidence at the surface and bulging of the vertical face of the trench, as shown in Figure A-7, below. If uncorrected, this condition can cause face failure and trap workers in the trench.

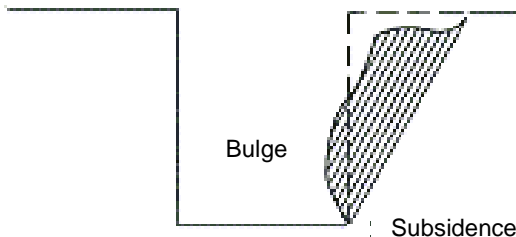

Figure A-7. Subsidence and bulging

## 2.4 Heaving or squeezing

Bottom heaving or squeezing is caused by downward pressure created by the weight of soil adjacent to the trench. This pressure causes a bulge in the bottom of the cut, as illustrated in Figure A-8, below.

Heaving and squeezing can occur even when shoring or shielding has been properly installed.

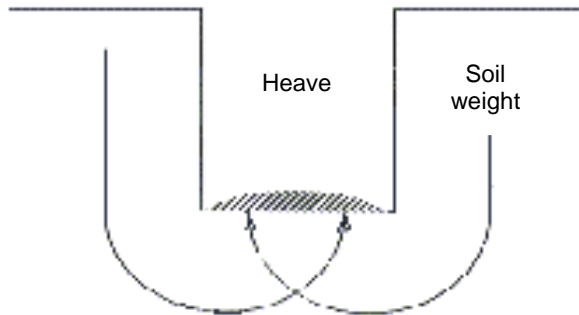

Figure A-8. Heaving or squeezing

## 2.5 Boiling

Upward water flow into the bottom of the cut is evidence of boiling. A high water table is one of the causes of boiling, as shown in Figure A-9, below. This requires a registered Professional Engineer (P.E.) to design the system. Boiling produces a "quick" condition (similar to quicksand) in the bottom of the cut, and can occur even when shoring or trench boxes are used.

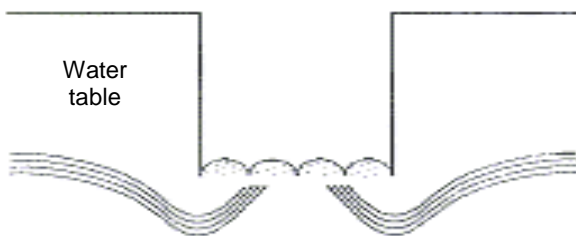

Figure A-9. Boiling

## 2.6 Unit weight of soils

Unit weight of soils is the weight of one unit of a particular soil. The weight of soil varies with type and moisture content. One cubic foot of soil can weigh from 110 pounds to 140 pounds or more, and one cubic meter (35.3 cubic feet) of soil can weigh more than 3,000 pounds.

## 3 The cave-in process

### 3.1 Surface weight causes sideways (lateral) pressure

The weight of the soil adjacent to the excavation, including any spoil pile, vehicles, equipment, foundations, and so on, exerts downward force due to gravity. The downward pressure, through soil mechanics, transfers force to the side wall of the trench, as shown in Figure A-10, below.

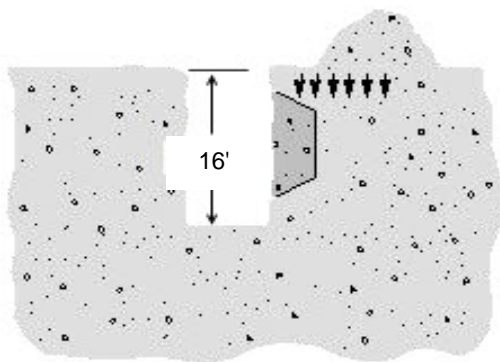

**Figure A-10. Soil loads exert side-wall force on excavation sides**

### 3.2 Trench wall bulges

The side of the trench bulges and creates a bulge or side-wall failure that is forced into the opening of the excavation, as shown in Figure A-11. This collapse is rapid and may appear to be instantaneous. There may be no warning before the trench wall collapses.

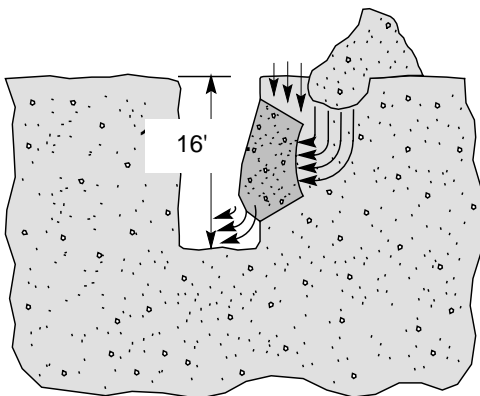

**Figure A-11. Trench wall bulges before failure**

### 3.3 Initial trench failure

The soil in the bulge collapses and fills the bottom of the excavation, as shown in Figure A-12. In this example, the initial flow of soil weighs 3,550 pounds. This weight presses down and traps personnel in the bottom of the trench. Crushing injuries may occur due to the weight of the soil.

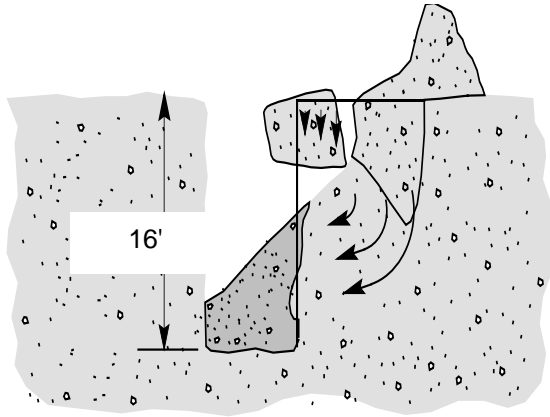

Figure A-12. Initial trench failure

### 3.4 Remainder of the earth face collapses

In one smooth, flowing motion, the remainder of the side excavation collapses and flows into the bottom of the excavation, adding additional weight to the soil that traps the employees. See Figure A-13 on page A-8.

#### WARNING

It is possible for an employee to suffocate in a standing position with his or her head above the ground due to the pressure of the soil on the chest and abdomen.

The remaining sides of the excavation may be unstable and may collapse and bury would-be rescuers. The soil can hide trapped workers and prevent the use of power equipment in their rescue.

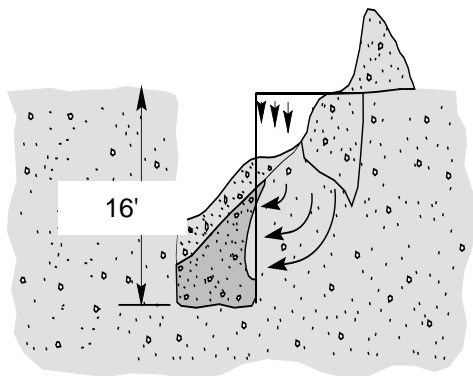

**Figure A-13. Excavation after side-wall collapse**

A soil excavation or hillside with cracking and soil tension continues to have sloughing, land subsidence, cave-ins, or spalling until the soil is once again in equilibrium and supported. This is why the Competent Person reviews the excavation at the beginning of each shift, as conditions change, and throughout the shift — to understand how stable the excavation is, and determine if any additional protection is needed.

This manual provides direction for installing worker protection when excavations are at or over 5' deep or any time there is a danger of a cave-in. Understanding how soil pressures and mechanics generally work, together with the protection systems and procedures shown in the manual, ensures that you have the knowledge to prevent such incidents.



## Appendix B

# Foreman's Guide for Briefing Cal/OSHA Inspectors

TD-4621M, Rev. 1  
Publication Date: 7/23/2014  
Effective Date: 1/1/2015

A Compliance Engineer (CE) representing Cal/OSHA or another regulator may come to the excavation to perform an inspection. This appendix outlines the basic steps of working with the inspector, and what you should be prepared to discuss with any inspector.

### 1

## What to do

The following steps are excerpted from SHC 207, "Regulatory Agency Inspections or Investigation." Order employee wallet cards through SAP, Code 623284.

1. Examine and verify the CE's ID.
2. Obtain the CE's business card.
3. Notify your exempt supervisor.
4. Notify safety and health personnel at (415) 973-8700/ internal 8-223-8700. Press option 1 for additional guidance.
5. Notify the CE that an exempt representative will be on the site, and in how many minutes.
6. If the CE will not wait for the exempt representative, and the inspection is to begin immediately, the employee in charge accompanies the CE and acts as the management representative.
7. The acting management representative:
  - a. Details the work site (including tools, equipment, work location and activities) using written notes or drawings.
  - b. Collects duplicates of physical samples taken by the CE.
  - c. Requests copies of photos taken.
  - d. Writes a description of photos taken.
  - e. Answer questions truthfully and directly. Do not speculate, offer an opinion, or volunteer information.
8. A CE is legally entitled to speak privately with employees. Ask the CE if you may attend.

2

## Inspector checklist

The Competent Person can use this checklist to brief a Cal/OSHA or other inspector who may visit the jobsite. Be prepared to discuss each of these items.

### 2.1 Personal information

My name is \_\_\_\_\_.

My job classification is \_\_\_\_\_.

I have worked for the Company \_\_\_\_\_ years.

I have worked in my job classification for \_\_\_\_\_ years.

### 2.2 The Competent Person

I am the Competent Person on this job. I have been trained in:

- Soils analysis.
- The use of protective systems.
- The requirements documented in the Company Excavation Safety Manual.

I have the authority to:

- Take prompt corrective action to eliminate existing and predictable hazards.
- Stop the work.

I have conducted daily inspections of the:

- Excavation(s)
- Adjacent area(s)
- Protective system(s)

My inspections were conducted (indicate which of the following apply):

- At the beginning of each shift.
- As needed throughout the work shift.
- After a rainstorm or other hazard-increasing event.

## 2.3 Soil classification

I used procedures found in the Company Excavation Safety Manual to classify the soil.

I used the \_\_\_\_\_ (visual test) and the \_\_\_\_\_ (manual test).

I found the soil to be primarily (choose only one):

\_\_\_\_\_ Sand

\_\_\_\_\_ Silt

\_\_\_\_\_ Clay

The initial soil classification was:

\_\_\_\_\_ A

\_\_\_\_\_ B

\_\_\_\_\_ C

\_\_\_\_\_ Solid rock

\_\_\_\_\_ Special case

I found these soil-destabilizing factors present on the job site:

\_\_\_\_\_ Submerged or flowing water

\_\_\_\_\_ Vibration

\_\_\_\_\_ Surcharge

\_\_\_\_\_ Previously disturbed soil

\_\_\_\_\_ Soil cracks or fissures

\_\_\_\_\_ Weak layers

\_\_\_\_\_ Structures or foundations

\_\_\_\_\_ Sloping ground

\_\_\_\_\_ Adverse weather

\_\_\_\_\_ How long the excavation will be open

Based upon the initial classification and the presence of destabilizing factors, my final soil classification was:

\_\_\_\_\_ A

\_\_\_\_\_ B

\_\_\_\_\_ C

\_\_\_\_\_ Solid rock

\_\_\_\_\_ Special case



## 2.4 Protective systems

I examined the ground for indications of cave-in potential.

I have examined the material used in the protective system and found that it is suitable for its intended use. Damaged equipment or material (if any) was \_\_\_\_\_.

## 2.5 Water conditions

- Dewatering equipment is/is not being used on this job.
- I am/am not monitoring the dewatering equipment and its operation.
- The excavation has/has not had water accumulation.
- The soil in the excavation has/has not been adversely affected.

## 2.6 Ramps

Ramps are/are not being used to provide access or egress to the excavation.

The ramps were designed by \_\_\_\_\_ for safe access and egress.

The ramps are/are not used for access and egress of equipment.

Ramps being used for equipment were designed by \_\_\_\_\_, who is qualified in structural design.

## 2.7 Confined space

I have completed the Company's confined space training.

The excavation **does/does not** meet the definition of a confined space. A confined space has the following:

- **Insufficient existing ventilation:** Existing ventilation is insufficient to remove dangerous air contamination or to address oxygen deficiency that may exist or develop.
- **Limited access:** Ready access or egress for removing a suddenly-disabled employee is difficult because of the location or the size of the openings.



# Appendix C

## Acceptable Bridges and Guardrails for Public Crossing of Excavations

TD-4621M, Rev. 1  
Publication Date: 7/23/2014  
Effective Date: 1/1/2015

Figures C-1, C-2 and C-3 on pages C-2 through C-3 show some acceptable guardrail designs for public crossings. Other designs that provide equivalent protection may be used.

### NOTE

Check local building regulations.  
More restrictive requirements may apply.

1

## Walkway

Construct the walkway of 1½" plywood or 2" planks. It must be wide enough for the anticipated foot traffic, including the physically challenged (e.g., wheelchairs).

2

## Toeboards

Toeboards on crossings are required only if someone will be working below or passing under the crossing. Check with your local regulations for specifics.

3

## Guardrails

Provide a smooth-surfaced top rail, a midrail, and a toeboard.

The ends of the rails must not overhang the terminal posts if the overhang is a projection hazard.

Design guardrails (including their connections and anchors) for a test load of 200 lbs. If heavy stress from crowds, trucking, handling materials, etc., is likely, use heavier stock; space the posts, bracing, and related material more closely together; etc.

Construct toeboards of wood, concrete, metal, or other suitable material. The top of the toeboard must be at least 4" above the walkway and the bottom clearance must not exceed ¼".

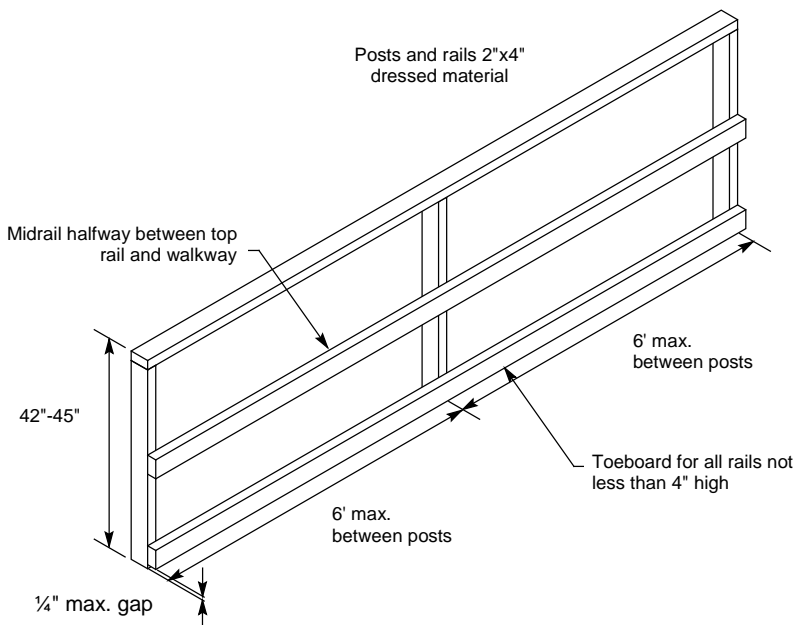

**Figure C-1. Wooden Rails for Crossing**

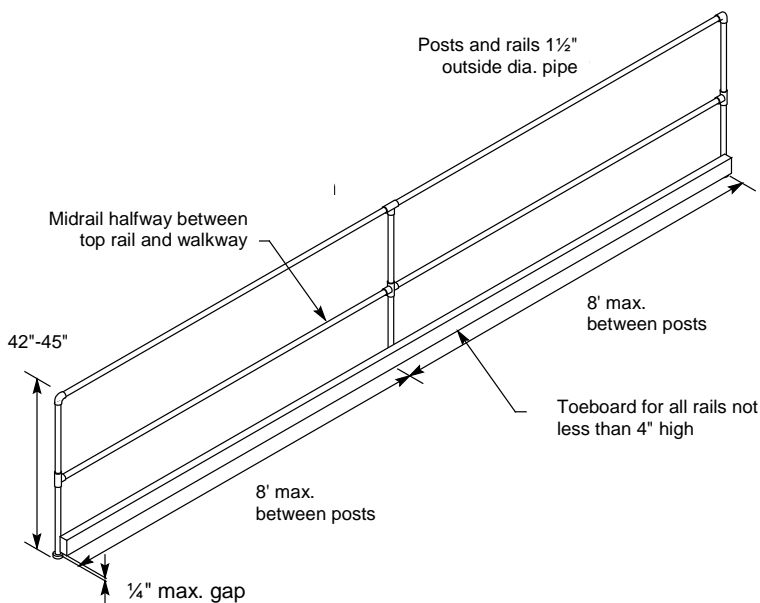

**Figure C-2. Pipe Rails for Crossing**

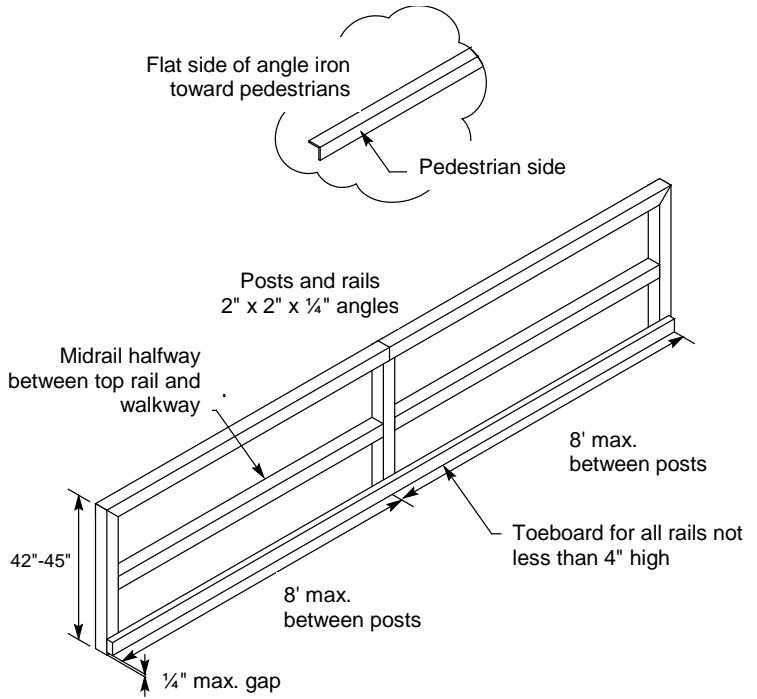

**Figure C-3. Structural Steel Rails for Crossing**

THIS PAGE INTENTIONALLY  
LEFT BLANK



## Appendix D

# Third-Party Protected Excavations

1

## Ensuring worker safety

Pacific Gas and Electric Company (the Company) uses contractors to perform utility work that often involves creating excavations and installing protective systems in excavations. Company workers and Competent Persons must know and understand what actions to take to ensure workers are safe in excavations dug by a third party.

As a Company Competent Person, you may use your “Stop Work” authority to ensure that no Company representative will enter an unsafe excavation.

This section provides instructions on:

- How to use tabulated data to verify the proper installation and safety.
- Actions to take if the excavation is not properly protected at the time the Company plans to enter the excavation.

Responsibility for the safety of the workers in the excavation rests with the employer of the workers, regardless of what entity dug the excavation. If you enter an excavation, it is your excavation.

### 1.1 Why third parties excavate for the Company

Cal/OSHA enforces safety and health regulations for every employer and place of employment in California. Therefore, any construction company that employs a worker is subject to Cal/OSHA regulations. Cal/OSHA regulations do not apply to owner-operator excavators. The regulations do apply to the Company and any worker entering the excavation prepared by the owner-operator. It is the Company’s responsibility to inspect the third-party-dug excavation and protective systems BEFORE workers enter the excavation to perform work for the Company.

### 1.2 Contractors

Contractors working for and with the Company are required to understand the concepts in this manual. They must be familiar with protecting their workers and creating shoring safety plans.

## 1.3 Pre-excavation notification

Make sure that excavation safety is a topic in any pre-construction meeting if the Company representative anticipates that workers will enter an excavation near 5' deep. Notify the applicant or contractor that shoring is likely to be necessary, and make sure that they have adequate knowledge and resources to address worker safety.

## 1.4 Site inspection before excavation

The job pre-check inspector has the responsibility of seeing that the excavations is properly protected. This should include reviewing:

- The shoring plan for the site.
- The site-specific safety plan.

Review the plan to determine if it is adequate for the work planned. If shoring, walers, shields, or any combination are in place, verify that the tabulated data is on-site and correct for the excavation you are pre-checking. Verify that the installation is aligned with the tabulated data for the size of excavation and type of protection.

Notify the responsible party on site of your findings, and that the excavation will be inspected on the day the excavation will be entered. Emphasize that conditions may change as the excavation remains exposed to the environment, and that the excavation protection system must be adjusted or modified for soil conditions that change.

# 2

## Verifying tabulated data

### 2.1 Hydraulic shoring

1. Review the tabulated data provided. Check that the type of shoring listed in the title is the type you see in the excavation. Verify that the data has been stamped and signed by a registered Professional Engineer (P.E.).
2. Review soil classification notes in the shoring plan or site safety plan. Observe freshly excavated soil, if available, as well as trench sides to validate the soil classification. Visual and manual tests may be performed.
3. Note the depth of the excavation, spacing of the horizontal and vertical members, if oversleeves are present if required, and the oversleeve size. Note the number of cylinders in each vertical rail.
4. Review size of vertical members listed and compare to size of vertical members in the excavation. Tabulated data may include both a standard and a heavy-duty member. Dimensions are shown on the tabulated data.

5. Verify the depth of the excavation. Using the tabulated data provided, for the classification of soil cited in Item 2 on page D-2, verify maximum vertical and horizontal spacing. Check installation for correct spacing.
6. Verify trench width compared to the tabulated data for oversleeve requirement.
7. Verify that sheeting, if installed, corresponds to the tabulated data requirements or the Company's requirements if not mentioned in tabulated data.
8. Verify that shoring is tight against trench wall with no voids.
9. Check that the pressure in the hydraulic cylinders matches the tabulated data requirement. There may be a gauge that will indicate a green zone.
10. If any of these steps finds a conflict or inappropriate use of the shoring, the excavation is not acceptable and must be discussed with the site representative in charge. Corrective action must be taken before entry by Company personnel.

## 2.2 Shields and boxes

1. View the box or shield provided. Validate and record model number, if available.
2. Review the soil classification notes in the shoring plan or site safety plan. Observe freshly excavated soil, if available, as well as the trench sides to validate the soil classification. Visual and manual tests may be performed.
3. Review the tabulated data provided on site. Look up the model number and verify maximum depth for type of soil onsite. Verify that the data has been stamped and signed by a registered P.E.
4. Visually check that pins and keepers are installed and appear secure. If hydraulic, verify that the pressure in the hydraulic cylinders matches the tabulated data requirement or is in the green zone on the gauge.
5. Check that the shield or box is no more than 2' above the bottom of the excavation for Type A and B soil, and extends to the bottom of the excavation for Type C soil. Backfill must extend  $\frac{1}{2}$  to  $\frac{2}{3}$  of the way up the side of the box to secure it snugly to the excavation wall.
6. For multiple sections, verify that all components of box are seated properly.
7. If any of these checks do not agree with the tabulated data provided, or shields are assembled improperly, the excavation is not acceptably protected. Specifics must be discussed with the site representative in charge. Corrective action must be taken before entry by Company personnel.



## 2.3 Walers

1. View the waler system installed. Validate and record model number, if available.
2. Review the tabulated data provided. Check that the waler model number recorded is in the tabulated data. Verify that the data has been stamped and signed by a registered P.E.
3. Review the soil classification notes in the shoring plan or site safety plan. Observe freshly excavated soil, if available, as well as the trench sides to validate the soil classification. Visual and manual tests may be performed.
4. Note the depth of the excavation, the spacing of the rails and cylinders, and whether extensions are present. If hydraulic, note the size of rails and number of struts.
5. Verify the depth of the excavation. Using the tabulated data provided, for the classification of soil cited in Item 3, above, verify maximum vertical and horizontal spacing. Check that this spacing requirement has not been exceeded in the excavation.
6. Verify that sheeting corresponds to the tabulated data requirements and is installed properly.
7. Verify that the waler system is tight against the trench wall with no voids.
8. Check that the pressure in the hydraulic cylinders matches the tabulated data requirement. There may be a gauge that indicates a green zone.
9. If any of these actions results in a conflict or inappropriate use of the shoring, the excavation is not acceptable. Discuss with the site representative in charge. Corrective action must be taken before entry by Company personnel.

## 2.4 Excavation safety discussions

When evaluation of the tabulated data and the protective system is complete, discuss the inspection results with the responsible site supervisor. State any issues discovered in the inspection and allow the responsible site supervisor to respond and take action to correct any issues. Set a time for a repeat inspection.

If issues arise that cannot be resolved, inform the site supervisor that the Company will not return, and the utility work must stop, until the excavation can be corrected. Escalation of the discussion may be referred to your supervisor.

## 2.5 Prepare to enter excavation

Upon successful inspection of the excavation safety systems, the excavation is ready for worker entry. Follow instructions in Part 3, Section 2, before entering the excavation.

### 3

## Checklist

Before entering an excavation, verify excavation protective system(s) installed by third party.

### NOTE

If excavation is benched or sloped, see Parts 7, 8, and 9 for details to support inspection.

### 3.1 All types of protection

- Ask to review the site safety plan or shoring plan, and tabulated data for the protective system installed.
- Verify that the tabulated data is stamped by a registered P.E.
- Perform soil classification, using at least one visual and one manual test.
- Document excavation size, including depth.
- Observe type of protective system installed, note size and spacing of members installed.
- Verify that sheeting, if present, is of size and type called out in tabulated data.
- Protective system is installed tight against walls (shoring, walers) or backfilled to prevent movement (shields, boxes).

Perform specific checks per the type of protection installed (see Appendix D, sections 3.2, 3.3, and 3.4, following).

### 3.2 Hydraulic shoring

Compare these items to the tabulated data for the soil type identified. Note any deficiencies.

- Verify correct size/spacing of vertical shores.
- Verify that oversleeves are installed correctly, if required.
- Verify that the correct number of cylinders for the depth of trench has been installed.
- Check pressure in each cylinder by reconnecting pump and ensuring gauge is indicating in the green zone or at the pressure specified.

### 3.3 Shields or shoring boxes

Compare these items to the tabulated data for the soil type identified. Note any deficiencies.

- Verify that the model type installed matches the tabulated data provided.
- Visually check that pins and keepers are installed and appear secure.
- If hydraulic, verify that the pressure in the hydraulic cylinders is adequate.
- Verify that the shield or box is no more than 2' above the bottom of the excavation for Type A and B soil, and extends to the bottom of the excavation for Type C soil.
- Verify that adequate backfill has been installed to restrict lateral movement. An industry best practice is to backfill  $\frac{1}{2}$  to  $\frac{2}{3}$  up the side of box.
- If multiple sections, verify that all components of the box are seated properly.

### 3.4 Walers

Compare these items to the tabulated data for the soil type identified. Note any deficiencies

- Verify that the rails and struts are the same material as identified in the tabulated data.
- Verify that the vertical and horizontal spacing of members is correct.
- If hydraulic, check pressure in each cylinder by reconnecting pump and ensuring gauge is indicating in the green zone or at the pressure specified.

### 3.5 End shoring

Any of the above protective systems can be used with each other and with end shores. End shores have their own tabulated data and are verified similarly to hydraulic shoring.

Document issues discovered and bring to the attention of the site supervisor for correction before entering excavation.



## Appendix E

# Effects of Water and Remedies

TD-4621M, Rev. 1  
Publication Date: 7/23/2014  
Effective Date: 1/1/2015

1

## Effects of water

The natural water table can cause many types of problems. For example, trenches excavated below the natural water table in sandy soils and soft clay are highly susceptible to heaving, the seepage of water at the bottom of the trench causing the soil to be pushed upward, as illustrated in Figure E-1, below. This heaving is a signal that a failure may occur.

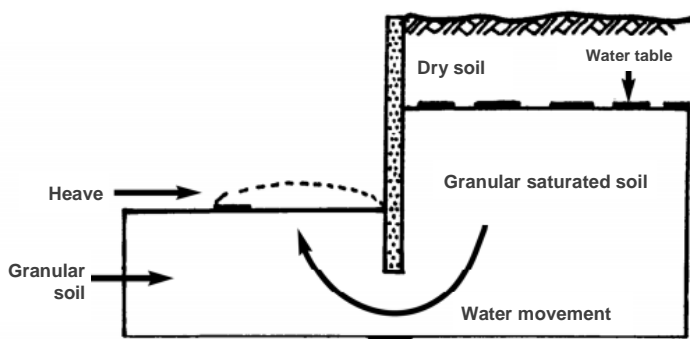

**Figure E-1. Heaving**

Wet conditions at the bottom of a trench may present another problem. If the bottom of the trench begins to puff and bubble and the earth rises, a quicksand condition is occurring. This is also a signal that a failure may occur.

2

## Dewatering

If heaving or quicksand conditions are expected, consider dewatering before beginning an excavation. Dewatering drastically reduces the presence of water and the additional pressure it causes. Without dewatering, a more robust protective system would be needed to support the extra pressures caused by the water. The two most frequently used dewatering systems are well-points and sump pumps.

## 2.1 Well-point system

The well-point system (illustrated in Figure E-2, below) is a very popular method of dewatering. Located on a line at least 2' behind the sheeting, well-points are inserted to the depth of the excavation. Spacing between the well-points varies from 3' to 8'.

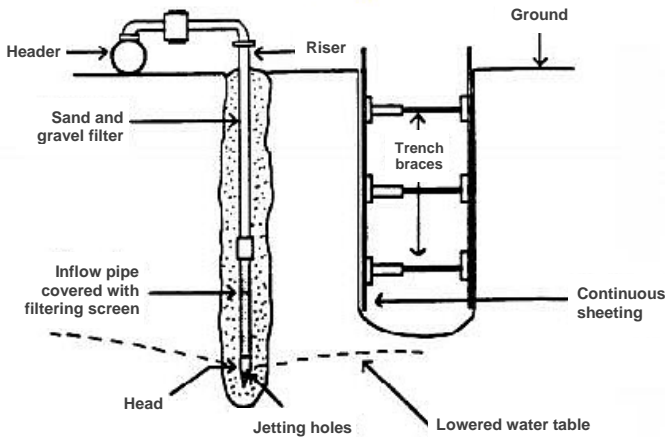

**Figure E-2. Well-points**

Well-points are pipes with a point at the lower end and a screen or filter over perforations along 3'-4' of the lower ends of the pipes. There are two types of well-points:

- Those driven with a maul.
- Those that are jetted in.

The selection of the size of the well-points and the required spacing are based on site conditions and the type of excavation to be accomplished. **Before** excavating, get help from a registered Professional Engineer (P.E.).

Above the ground, well-point pipes are connected by piping to a high-capacity pump. Pumping keeps the water level below the bottom of the excavation so that only a moist soil condition will be encountered within the excavation.

The well-point system should have a capacity sufficient to remove any inflow of water as quickly as it occurs. The depth limit of this method's practical effectiveness is approximately 15'-20', sufficient for protection in excavations.

Dewatering does not permit any substantial excavation without providing ground support. Although the dewatered soil is usually firmer than it was before dewatering, working conditions may still be unsafe. Shoring, or banked walls at a safe slope, should be used in dewatered ground in the same manner as in any other excavation.

## 2.2 Sump pump

The second common type of dewatering system is the sump pump, as shown in Figure E-3.

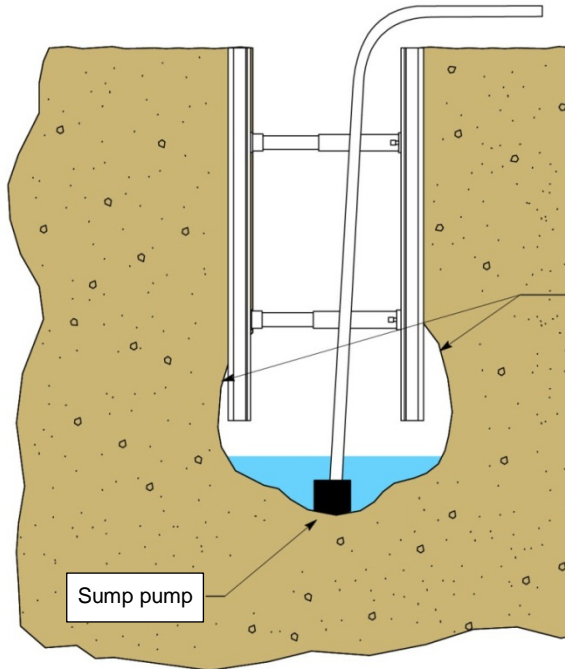

**Figure E-3. Dewatering with a sump pump**

Sump pumping, as contrasted with well-pointing, has several advantages. Sump pumps:

- Can be installed quickly by inexperienced labor.
- Require less space and cause less interference on the site.
- Can be added or removed easily to meet required pumping capacity.
- Can be started by simply switching on the power supply because no balancing or turning is required.
- Do not freeze in cold weather because of the fast, high volume flow of water.
- May be removed from one sump and used elsewhere if needed.
- Usually cost less than well-points.

THIS PAGE INTENTIONALLY  
LEFT BLANK



# Appendix F

## References and Related Resources

TD-4621M, Rev. 1  
Publication Date: 7/23/2014  
Effective Date: 1/1/2015

### Part 1

Code of Federal Regulations (CFR) Title 29, Labor, Part 1926—  
Safety and Health Regulations for Construction, Subpart P –  
Excavations, Section 1926.650, “Scope, application, and  
definitions applicable to this subject.”

California Code of Regulations (CCR), Title 8, “Construction  
Safety Orders,” Subchapter 4, Article 6, “Excavations”, Section  
1540 (b) Definitions.

8 CCR Subchapter 4, Article 6, § 1541.1, Appendix A (b).

8 CCR Subchapter 4, Article 6, § 1504 (a).

OSHA Technical Manual (OTM), Section v, Chapter 2,  
“Excavations: Hazard Recognition in Trenching and Shoring,” II  
Definitions.

### Part 2

#### Figure 2-1

8 CCR Subchapter 4, Article 6, § 1541.1, Appendix F.

### Part 3

29 CFR § 1926, Subpart P, Appendix A (b).

8 CCR Subchapter 4, Article 6, § 1541(g).

8 CCR Subchapter 4, Article 6, § 1541.1, Appendix A (b).

8 CCR Subchapter 4, Article 6, § 1541.1, Appendix A (d).

8 CCR Subchapter 4, Article 6, § 1541.1, Appendix F.

### Part 5

#### Figure 5-4

29 CFR § 1926.451 (e)(5).

29 CFR § 1926.651 (c)(1)(i –v).

8 CCR Subchapter 4, Article 6, § 1541 (c) (2), and (l).



## Part 7

### **Figures 7-1 and 7-3**

29 CFR § 1926, Subpart P, Appendix D (g), Table D-1.1.

29 CFR § 1926, Subpart P, Appendix B (c), Figure B-1.1.3.

### **Figure 7-5**

29 CFR § 1926, Subpart P, Appendix B (c), Figure B-1.1.3.

### **Table 7-2**

29 CFR § 1926, Subpart P, Appendix B (c), Figure B-1.1.1.

### **Table 7-4**

29 CFR § 1926, Subpart P, Appendix B (c), Figure B-1.1.3.

8 CCR Subchapter 4, Article 6, § 1541.1, Appendix B (c),  
Figure B-1.1.3.

### **Table 7-5**

29 CFR § 1926, Subpart P, Appendix B (c), Figure B-1.4.1.

8 CCR Subchapter 4, Article 6, § 1541.1, Appendix B (c),  
Figure B-1.4.1.

### **Table 7-6**

29 CFR § 1926, Subpart P, Appendix B (c), Figure B-1.4.1.

8 CCR Subchapter 4, Article 6, § 1541.1, Appendix B (c),  
Figure B-1.4.1.

### **Table 7-7**

29 CFR § 1926, Subpart P, Appendix B (c), Figure B-1.4.1.

8 CCR Subchapter 4, Article 6, § 1541.1, Appendix B (c),  
Figure B-1.4.1.

### **Table 7-8**

29 CFR § 1926, Subpart P, Appendix B (c), Figure B-1.4.1.

8 CCR Subchapter 4, Article 6, § 1541.1, Appendix B (c),  
Figure B-1.4.1.

### **Table 7-10**

29 CFR § 1926, Subpart P, Appendix B (c), Figure B-1.1.2.

8 CCR Subchapter 4, Article 6, § 1541.1, Appendix B (c),  
Figure B-1.1.2.

### **Table 7-11**

29 CFR § 1926, Subpart P, Appendix B (c), Figure B-1.1.2.

8 CCR Subchapter 4, Article 6, § 1541.1, Appendix B (c),  
Figure B-1.1.2.

## Part 8

### Figure 8-4

29 CFR § 1926, Subpart P, Appendix D.

8 CCR Subchapter 4, Article 6, § 1541.1, Appendix D.

### Figure 8-7

29 CFR § 1926, Subpart P, Appendix B (c), Figure B-1.2.3.

8 CCR Subchapter 4, Article 6, § 1541.1, Appendix B (c),  
Figure B-1.2.3.

### Table 8-2

29 CFR § 1926, Subpart P, Appendix D.

8 CCR Subchapter 4, Article 6, § 1541.1, Appendix D, Figure 4,  
Table D-1.3.

### Table 8-3

29 CFR § 1926, Subpart P, Appendix B (c), Figure B-1.2.1.

8 CCR Subchapter 4, Article 6, § 1541.1, Appendix B (c),  
Figure B-1.2.1.

### Table 8-4

29 CFR § 1926, Subpart P, Appendix B (c), Figure B-1.4.1.

8 CCR Subchapter 4, Article 6, § 1541.1, Appendix B (c),  
Figure B-1.4.1.

### Table 8-5

29 CFR § 1926, Subpart P, Appendix B (c), Figure B-1.4.1.

8 CCR Subchapter 4, Article 6, § 1541.1, Appendix B (c),  
Figure B-1.4.1.

### Table 8-6

29 CFR § 1926, Subpart P, Appendix B (c), Figure B-1.4.1.

8 CCR Subchapter 4, Article 6, § 1541.1, Appendix B (c),  
Figure B-1.4.1.

### Table 8-7

29 CFR § 1926, Subpart P, Appendix B (c), Figure B-1.4.1.

8 CCR Subchapter 4, Article 6, § 1541.1, Appendix B (c),  
Figure B-1.4.1.

### Table 8-9

29 CFR § 1926, Subpart P, Appendix B (c), Figure B-1.2.2.

8 CCR Subchapter 4, Article 6, § 1541.1, Appendix B (c),  
Figure B-1.2.2.

## Part 9

### Section 9-2

29 CFR § 1926, Subpart P, Appendix D.

8 CCR Subchapter 4, Article 6, § 1541.1, Appendix D.

### Figure 9-3

29 CFR § 1926, Subpart P, Appendix B, Figure B-1.3.1

8 CCR Subchapter 4, Article 6, § 1541.1, Appendix B (c),  
Figure B-1.3.1

### Table 9-1

29 CFR § 1926, Subpart P, Appendix D.

8 CCR Subchapter 4, Article 6, § 1541.1, Appendix D, Figure 4,  
Table D-1.3.

### Table 9-2

29 CFR § 1926, Subpart P, Appendix B, Figure B-1.3.1.

8 CCR Subchapter 4, Article 6, § 1541.1, Appendix B (c),  
Figure B-1.3.1.

### Table 9-3

29 CFR § 1926, Subpart P, Appendix B, Figure B-1.4.1.

8 CCR Subchapter 4, Article 6, § 1541.1, Appendix B (c),  
Figure B 1.4.1.

### Table 9-4

29 CFR § 1926, Subpart P, Appendix B, Figure B-1.4.1.

8 CCR Subchapter 4, Article 6, Section 1541.1, Appendix B,  
Figure B-1.4.1.

### Table 9-5

29 CFR § 1926, Subpart P, Appendix B, Figure B-1.4.1.

8 CCR Subchapter 4, Article 6, §1541.1, Appendix B (c),  
Figure B-1.4.1.

### Table 9-6

29 CFR § 1926, Subpart P, Appendix B (c), Figure B-1.4.1.

8 CCR Subchapter 4, Article 6, § 1541.1, Appendix B (c),  
Figure B-1.4.1.

## Appendix A

OTM Section V: Chapter 2, "Excavations: Hazard Recognition in Trenching and Shoring."

North Carolina Department of Labor, Occupational Safety and Health Division, "A Guide to the OSHA Excavations Standard", updated 2011:

<http://www.nclabor.com/osha/etta/indguide/ig14.pdf>

## Appendix E

8 CCR Title 8, Subchapter 4, Article 6, 1541, (h)(1) to (2).

North Carolina Department of Labor, Occupational Safety and Health Division, "A Guide to the OSHA Excavations Standard", updated 2011:

<http://www.nclabor.com/osha/etta/indguide/ig14.pdf>

## Publications

Utility Standard C-T&CS-S0213, "Work Procedures in Confined Spaces."

Utility Standard S4412, "Damage Prevention Manual."

*Final Report: Guidelines for the Support of Utility Excavations*, prepared by School of Civil and Environmental Engineering, Cornell University, Ithaca, NY 14850-3501. Published by the Gas Research Institute, 8600 Bryn Mawr Avenue, Chicago, IL 60631-3562.

*Underground Focus Magazine, The Magazine of Below-Ground Damage Protection* (ISSN: 1090-400X) available from Canterbury Communications, Inc., PO Box 638, Spooner, WI 54801. Subscriptions are restricted to those whose jobs involve placement, maintenance, or protection of underground distribution systems.

Interstate Natural Gas Association of America (INGAA) Construction Safety Consensus Guidelines – "Trenching and Excavations Safety" Draft, December 2011.

*A Guide to OSHA Excavations Standard*, North Carolina Department of Labor - Occupational Safety and Health Program. Updated 2009.

<http://www.safety.duke.edu/ohs/Documents/ig14.pdf>

## Online References

### **29 CFR § 1926**

[http://www.ecfr.gov/cgi-bin/text-idx?SID=1e3d9abec5128417e151c12c4ef37c83&c=ecfr&tpl=/ecfrbrowse/Title29/29cfrv8\\_02.tpl](http://www.ecfr.gov/cgi-bin/text-idx?SID=1e3d9abec5128417e151c12c4ef37c83&c=ecfr&tpl=/ecfrbrowse/Title29/29cfrv8_02.tpl)

8 CCR Subchapter 4, Article 6, § 1540

<http://www.dir.ca.gov/title8/1540.html>.

8 CCR Subchapter 4, Article 6, § 1541

<http://www.dir.ca.gov/title8/1541.html>.

8 CCR Subchapter 4, Article 6, § 1541.1

<http://www.dir.ca.gov/title8/1541.1.html>.

*Underground Focus Magazine*

<http://www.underspace.com>

National Utility Locating Contractors Association

<http://www.nulca.org>

OSHA Regulations for Ramps

[http://www.ehow.com/list\\_5925862\\_osh-regulations-ramps.html#ixzz2AAPRPoMO](http://www.ehow.com/list_5925862_osh-regulations-ramps.html#ixzz2AAPRPoMO)

Cal/OSHA Tailgate/Toolbox Topics

[http://www.dir.ca.gov/dosh/dosh\\_publications/tb\\_trench.pdf](http://www.dir.ca.gov/dosh/dosh_publications/tb_trench.pdf)

*Work Area Protection guide*

Company Intranet

[http://wssascon/SEandHS/Shared%20Documents/Web%20Docs/Manuals/Work\\_Area\\_Protection.pdf](http://wssascon/SEandHS/Shared%20Documents/Web%20Docs/Manuals/Work_Area_Protection.pdf)

## **APPENDIX N**

### **PG&E Slope Safety Standard**



## Slope Safety

### Summary

This utility procedure identifies hazards associated with working on sloped or angled terrain and describes appropriate work methods to mitigate potential slip and fall hazards.

Level of Use: Information Use

---

### Target Audience

All electric maintenance and construction (EM&C), general construction, electric transmission (ET), and restoration employees.

---

### Safety

- Slope safety is defined as using conventional [American National Standards Institute](#) (ANSI)- and Pacific Gas and Electric Company (PG&E)-approved fall protection equipment on sloped surfaces greater than 40°.
- Where a free fall over 2 feet (ft) exists, always use fall arrest equipment. Knot tying is not permitted where loads need support.
- Workers may only use approved fall protection equipment. Many Conformity European (CE) equipment types are not PG&E-approved (for example, non-ANSI-approved rope grabs).
- It is PG&E policy that employees not be exposed to fall hazards. When practical, design or retrofit work areas and processes to eliminate fall hazards before starting work.
- All workers on the job must understand their roles and how those roles relate to the overall work plan, as well as the hazards and hazard controls associated with the job.
- Where feasible, employ approved fall protection systems. Where using a fall protection system is not feasible, implement approved work procedures to protect employees from falls.
- When using a life line, each person must be anchored to a separate, unquestionably strong anchor and life line.
- Only one person may be attached to a life line at a time.
- If the first person ascending or descending a slope reaches stable footing on a slope less than 40°, that person may detach from the life line. The next person may then attach to the same life line to ascend or descend the slope.

## Slope Safety

- Before You Start**
- Consider all methods of accessing a site to determine if the worksite is accessible without ascending or descending the slope (helicopter long-line-certified employees, alternate route, line-throwing gun, etc.)
  - Evaluate and discuss the hazards associated with a sloped or angled jobsite.
  - Complete PG&E Course, “Safety at Heights – Authorized Person” (at a minimum).
    - **Authorized person:** A person designated by PG&E who, by reason or training or experience, can work safely at heights and knows how to select and use fall protection equipment properly.
    - **Competent person:** “One who is capable of identifying existing and predictable hazards in the surroundings or working conditions which are unsanitary, hazardous, or dangerous to employees, and who has authorization to take prompt corrective measures to eliminate them.” ([California Code of Regulations, Title 8, Subchapter 4, Article 2](#))
    - **Qualified person:** “A person designated by the employer who by reason of training, experience or instruction has demonstrated the ability to safely perform all assigned duties and, when required, is properly licensed in accordance with federal, state, or local laws and regulations.” ([California Code of Regulations, Title 8, Subchapter 4, Article 2](#))

### Table of Contents – Procedures

Subsection	Title	Page
1	First Aid Emergency Procedures.....	3
2	Evaluating the Hazards .....	3
3	Accessing a Slope .....	6
4	Tools and Equipment – Harnesses .....	11
5	Ropes and Life Lines.....	12



## Slope Safety

### Procedures

#### 1 First Aid Emergency Procedures

- Before ascending or descending slopes at the jobsite, establish a site emergency/first aid response plan; document this plan using the jobsite tailboard form and magnetic placard. Ensure the information is complete, communicated, and understood by the entire crew.
- When working alone, perform and document a single-worker tailboard. Always discuss the following information with the person in charge (PIC) – for example, the supervisor:
  - Exact location (global positioning system [GPS] and/or physical location).
  - Time the employee reports back to the PIC after ascending or descending a slope.
  - A follow-up plan in the event the employee is unable to report back at the designated time.

#### 2 Evaluating the Hazards

- When practical, ensure that work areas and processes are designed or retrofitted to eliminate fall hazards.
- Consider all methods of accessing the worksite before working on slopes. Determine if the work can be performed without ascending or descending the slope (helicopter long-line-certified employees, alternate route, line-throwing gun, etc.).



#### CAUTION

There is no state or federal requirement for working on sloped surfaces less than 40°. However, sloped surfaces less than 40° may pose a hazard. Always consider using fall protection under these circumstances.

2.1 When working on slope surfaces steeper than 40°, adhere to the following guidelines:

- Using fall protection equipment is required, per the [Safety Engineering and Health Services \(SEHS\) Safety at Heights User Guide](#).
- Using a fall arrest system is required when working on a slope ending in a cliff.
- A minimum of two people are required and a fall arrest system must be used when working on a slope where a drop-off greater than 2 ft exists.



## Slope Safety

2.2 IF a hazard cannot be abated through design and any of the following conditions exist:

- The potential vertical fall distance is 2 ft or greater.
- There are sloped roof surfaces steeper than 7:12.
- There are sloped surfaces steeper than 40°.

THEN employ approved fall protection systems, where feasible.

2.3 IF using a fall protection system is not feasible,

THEN implement approved [Safety at Heights User Guide](#) procedures to protect employees from falls. If necessary, contact a Safety at Heights qualified person (QP) before starting work.

2.4 Before starting work, evaluate and discuss the hazards associated with sloped or angled worksites.

2.5 Always assess the environment. The following is a partial list of work environment and footing conditions to consider:

- What are the general soil conditions (for example, dry and loose or wet and slippery)?
- What are the terrain conditions (for example, general stability, loose rocks, leaves, debris, bush, uneven or moss covered surfaces, steep drop off)?
- What type of vegetation is at the worksite and how might it impact jobsite safety?
- What is the potential for falling/sliding objects (for example, rocks and tools)?
- What are the weather conditions and how might they impact the workers' ability to perform the job safely?
- Is visibility and lighting sufficient to perform the job safely?
- Is the crew properly staffed or are additional resources needed?
- Are approved tools and equipment available at the jobsite to access the slope safely?
- What personal protective equipment (PPE) is needed to perform the job safely? (Be sure to include foot wear for ankle support and traction.)
- Are the workers' hands free of materials and tools while ascending or descending slopes?

## Slope Safety

### 2.6 Identifying a Slope Hazard

Use a slope indicator to determine the angle of the slope or worksite where employees will be working or must access. (Backcountry slope meter: Code BCASS-10)

- A bubble level or inclinometer may be used to indicate slope angle.
- A protractor may be used ([Figure 1](#)), as described in the following [Section 2.7, "Identifying Slope Angle Using a Protractor."](#)

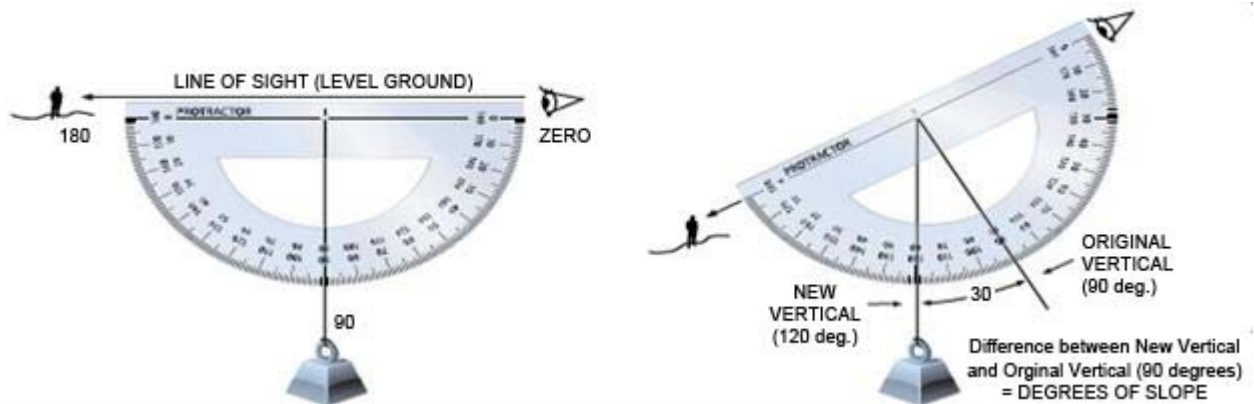

**Figure 1. Identifying Slope Angle Using a Protractor**

### 2.7 Identifying Slope Angle Using a Protractor

1. Attach the string to the protractor at the midpoint between the zero and 180° marks (the vertex of the angle).
2. Hang a small weight on the end of the string to make a plumb-bob. The string should hang over the 90° mark when the protractor's flat edge is parallel to level ground.
3. To measure the slope angle from the top of the slope, put your eye by the zero degree mark, and look along the flat edge of the protractor toward the bottom of the hill. If you are at the bottom of the hill, put your eye at the 180° mark and look up toward the top.
4. Check the new angle where the string falls when the plumb-bob is hanging straight down.
5. To ascertain the slope measurement in degrees, subtract 90° from the new vertical angle. In [Figure 1](#) the new angle is 120°, so the slope angle is 30° (120-90=30).
6. To be as accurate as possible, look along the protractor's edge to a point the same height above the ground as eye level. (It helps to imagine someone the same height standing at the other end of the slope.)



## Slope Safety

### 3 Accessing a Slope

3.1 Consider the following partial list of precautions when accessing a slope:

- Access the worksite from above whenever possible. Employees must always be attached to a fall protection system, provided there is a suitable anchor.
- Maintain a sharp visual and mental focus (keep eyes on path) when ascending or descending a slope.
- Wear heavy, Vibram-type boots with good ankle support.
- Use a side step method, if necessary, to maintain stable footing.
- Use a hiking stick or pole for balance.
- Proceed with caution, maintaining a firm footing with each step (take smaller steps).
- Create a step at the worksite for level footing, if needed.

3.2 When using a life line, each person must be anchored to a separate, unquestionably strong anchor. Make sure the anchor is connected at the following points:

- To the frame or other anchor points of a vehicle weighing more than 5,000 pounds (lb.) for fall arrest. Make sure the vehicle ignition is off, the key is removed, and the man-on-line (MOL) tag (notifying others that the vehicle is being used as an anchor) is attached to the steering wheel.
- To a large, firmly planted tree greater than 8 inches in diameter.

3.3 IF there are no suitable anchor points (such as a tree, pole, tower, or truck),

THEN re-evaluate the worksite access. Terrain variables do not allow for a portable engineering solution.

3.4 Accessing a Slope from Above

1. Assess the entire jobsite and slope for potential hazards from the top of the slope.
2. Identify appropriate anchor(s).
3. Ensure that the entire crew participates in a tailboard. Tailboard topics must include the documented emergency plan and all identified, discussed, and mitigated hazards. The entire crew must understand all aspects of the job and emergency plan.
4. Attach a  $\frac{5}{8}$ -inch green life line to the anchor (using a permanently attached steel sling with a minimum  $\frac{5}{8}$ -inch shackle or a 5,000 lb. carabiner).

## Slope Safety

3.4 (continued)



**Figure 2. 5/8-Inch Green Life Line**

5. IF the steel sling is too short,  
THEN choke an improvised anchor strap ([Figure 3](#)) around the anchor, and attach the steel sling eye to the D-ring on the improvised anchor strap with a minimum 5/8-inch shackle or 5,000 lb. carabiner.



**Figure 3. Improved Anchor Strap**  
(See [Table 2](#) on Page 13 for ordering information.)

6. Put on and adjust an approved full body harness ([Figure 4](#), Page 11).
7. Attach the shock pack end of shock absorbing lanyard ([Figure 6](#), Page 12) to the dorsal (back) D-ring on the harness, and attach the other end to the compatible Buckingham rope grab using approved 5,000 lb. carabiners supplied with shock absorbing lanyard.
8. Attach the approved and compatible Buckingham rope grab ([Figure 6](#)) to the life line with the arrow pointing toward the anchor.
9. Begin walking down the slope while holding the rope and moving the rope grab down the rope.
10. When at the worksite, if the slope is over 40°, pull down on the ring of rope grab to lock the rope grab on the life line.
11. Keep equipment on while working on the ground at this location unless the slope can be minimized to less than 40° by digging, relocating to a flatter area, etc.

## Slope Safety

### 3.4 (continued)



#### CAUTION

Only one person may be attached to any life line at a time.

#### NOTE

When using a life line, each person must be anchored to a separate, unquestionably strong anchor and life line.

12. IF the first person remains on the first life line,  
THEN the next person repeats [Steps 4-10](#) (starting on Page 6).
13. IF the first person reaches stable ground with less than 40° of slope and disconnects from the life line,  
THEN the next person repeats [Steps 6-10](#) (on Page 7) for each person accessing the slope.
14. Reverse these steps (Section 3.4, "Accessing a Slope from Above," [Steps 1-13](#) starting on Page 6) to ascend the slope after the work is completed.

### 3.5 Accessing Slope from Below

#### 1. First Person Up

The first person up performs the following [Steps a-j](#) to access a slope from below:

- a. Assess the entire jobsite from the bottom of the slope for potential hazards.
- b. Ensure that the entire crew participates in the tailboard. Tailboard topics must include the documented emergency plan and all identified, discussed, and mitigated hazards. The entire crew must understand all aspects of the job and emergency plan.
- c. Put on and adjust the approved full body harness ([Figure 4](#), Page 11).
- d. Coil the life line up and carry it over your shoulder, or uncoil and attach the life line steel sling to the harness, dragging the life line rope up the hill by the steel sling.
- e. Carry an additional short life line to secure the first person up to a separate anchor, in the event the first person up cannot reach stable ground with less than a 40° slope and additional people will be ascending the hillside.

## Slope Safety

3.5 (continued)



### CAUTION

Use extreme caution while ascending a hillside. Consider moving up the hill in a switchback pattern, and side step up and along the path to ensure there is a solid foundation for each step. (Consider using a hiking stick/pole for balance.)

- f. Use extreme caution while ascending the hillside.
- g. When the worksite is reached, identify the appropriate anchor(s).
- h. IF the first person up cannot reach stable ground with less than a 40° slope,  
THEN the first person up attaches a short  $\frac{5}{8}$ -inch green life line ([Figure 2](#), Page 7) to the appropriate anchor using a permanently attached steel sling with a minimum  $\frac{5}{8}$ -inch shackle or 5,000 lb. carabiner.
- i. IF the steel sling is too short,  
THEN choke an improvised anchor strap ([Figure 3](#), Page 7) around the anchor, and attach the steel sling eye to the D-ring on the improvised anchor strap with a minimum  $\frac{5}{8}$ -inch shackle or 5,000 lb. carabiner.
  - (1) Attach the shock pack end of shock absorbing lanyard ([Figure 6](#), Page 12) to the dorsal (back) D-ring on the harness.
  - (2) Attach the approved and compatible Buckingham rope grab to the other end of the shock absorbing lanyard using approved 5,000 lb. carabiners supplied with shock absorbing lanyard.
  - (3) Attach the approved and compatible Buckingham rope grab ([Figure 6](#)) to the life line with the arrow pointing toward the anchor.

### NOTE

When using a life line, each person must be anchored to a separate, unquestionably strong anchor and life line.



### CAUTION

Only one person may be attached to any life line at a time

- j. Attach the other  $\frac{5}{8}$ -inch green life line to another appropriate anchor (see [Step h](#) above).

## Slope Safety

### 3.5 (continued)

#### 2. Next Person Up

The next person up ascends the hillside using the vacant life line ([Steps a-g](#) below).

- a. Put on and adjust an approved full body harness ([Figure 4](#), Page 11).
- b. Attach the shock pack end of shock absorbing lanyard ([Figure 6](#), Page 12) to the dorsal D-ring on the harness, and attach the other end to the Buckingham rope grab.
- c. Attach the approved and compatible Buckingham rope grab ([Figure 6](#)) to the life line with the arrow pointing toward the anchor.
- d. IF the next person up will remain on the life line at the worksite,  
  
THEN that person will take another life line up, and attach the life line to another appropriate anchor for the next person.
- e. The next person up begins walking up the slope, while holding the rope and moving the rope grab up the rope.
- f. When at the worksite, if the slope is over 40°, pull on the rope grab to lock it on the life line.
- g. Keep equipment on while working on the ground at this site unless the slope can be minimized by digging, relocating to a flatter area, etc.
- h. Reverse [Steps a-g](#) above to descend the slope after the work is completed.

#### 3. Last Person Down

The last person to walk down the slope must disconnect the remaining life lines from the anchors so they can be pulled down the hill.



#### CAUTION

Use extreme caution while descending a hillside. Consider moving down the hill in a switchback pattern, and side step down and along the path to ensure there is a solid foundation for each step. (Consider using a hiking stick/pole for balance.)



## Slope Safety

### 4 Tools and Equipment – Harnesses

For information regarding other tools and equipment, see the SEHS [Safety Equipment Guide](#).

#### 4.1 Full Body Harness

A full body harness is designed with straps that fasten around a person to contain their torso and distribute fall arrest forces over at least their upper thighs, pelvis, chest, and shoulders (with a means for attaching the harness to other components or subsystems).

Workers may use front, side, or back D-rings with a full body harness. While working on steeper slopes, workers must employ a fall arrest system and use a back D-ring as the attachment point.

#### 4.2 Fall Arrest Harness

A fall arrest harness has a single forged D-ring affixed to the shoulder straps and positioned between the shoulder blades. It allows workers to climb and work without interference from the rope. The dorsal attachment ensures that an individual hangs in an upright position after a fall and that the forces of a fall are distributed correctly. The upright position is especially helpful if the fallen worker is unconscious or injured. This design enables workers to be safe and reasonably comfortable while suspended for prolonged periods of time.

#### 4.3 PG&E-Approved Harnesses

When working on slopes, use any of the following harnesses:

- Buckingham Harness.
- DBI Exofit – XP Full Body 4 D-Ring Harness ([Figure 4](#)).
- Yates Tower Harness.



**Figure 4. DBI Exofit – XP Full Body 4 D-Ring Harness**

## Slope Safety

### 5 Ropes and Life Lines

- 5.1 Rope is defined as any cordage (synthetic or natural) with an external diameter greater than 3/16 inch (4 millimeters [mm]). The length may be twist balanced, as in a “laid” rope, or braided.
- 5.2 Vertical Life Line ([Figure 5](#) and [Table 1](#) below)

A component, element, or constituent of a life line subsystem consists of a vertically suspended flexible line with a connector at the upper end for fastening the line to an overhead anchor or anchor connector, along which a fall arrester travels.

[Figure 5](#) and [Figure 6](#) are illustrations of the PG&E-approved rope/vertical life line with compatible shock pack and rope grab.



Figure 5. 5/8-Inch Green Life Line



Figure 6. Rope Grab and Buckingham Lanyard for Use with 5/8-Inch Green Life Line

Table 1. Single Braided 12-Strand Rope for Fall Arrest Systems – Requirements and Ordering Codes

Rope Size (inches)	Minimum Breaking Strength (lbs)	Approximate Net Weight per 100 ft (lbs)	Diameter (inches)	M&S Ordering Codes
5/8	15,000	13.1 ±/-.5	0.657 ±/-.015	
<b>Standard Fall Arrest System Ropes</b>				
	Specify length of rope			20-9276
<b>Tower Structure Fall Arrest System Ropes</b>				
	25 ft length			20-9277
	40 ft length			20-9278
	Specify length of rope			20-9279
<b>Rope Grab Devices</b>				
	MIO 5/8-inch rope grab (non-free following)			20-9280
	3 ft Buckingham Energy Absorbing Lanyard, Pt. No. 611113			20-9282
	*RTC Rope Grab and Energy Absorbing Lanyard (free following), Mod. No. 23000P3E			20-9281

\*Do not use the RTC Rope Grab and Energy Absorbing Lanyard with a Buckingham Bucket Harness.

## Slope Safety

5.2 (continued)

**Table 2. Improvised Anchor Strap – Ordering Information** (See [Figure 3](#) on Page 7 for illustration.)

Supplier Part #	Description	Manufacturer Part #
DBI1002200	Tie-off adapter, 3 ft long – welding and arc-flash rated (made with Kevlar)	1002200
DBI1002202	Tie-off adapter, 6 ft long – welding and arc-flash rated (made with Kevlar)	1002202
DBI1002207	Tie-off adapter, 12 ft long (for CRE only), welding and arc-flash rated (made with Kevlar)	1002207
DBI1002206	Tie-off adapter, 20 ft long (for CRE only), welding and arc-flash rated (made with Kevlar)	1002206

Tie-off adapters wrap around a structural member to provide an anchorage point for fall restraint/arrest systems. Pass a tie-off adapter through a type D-ring, 1-<sup>3</sup>/<sub>4</sub> inch polyester load strap, with a 3-inch wide wear pad and green webbing down the middle of the strap.

### 5.3 Horizontal Life Line

The horizontal life line consists of an anchor, anchor connector, life line, and a variety of subsystems. The entire system (from anchor to body support) must be designed, engineered, and approved by a QP and must have a safety factor of at least two.

QP(s) designing or engineering horizontal life line systems **must** conduct appropriate research, maintain adequate safety margins, and receive additional training on designing man-rated systems. Employees may not install or use a horizontal life line for fall arrest unless a QP has properly designed or engineered such life line. Horizontal life line systems are relatively flexible in type, situation, size, and the span they can accommodate.

**END of Instructions**



## Slope Safety

### Definitions

**Fall arrest system:** Prevents an employee from free falling to the ground. Always wear a full body harness as part of a fall arrest system.

**Fall arrester (rope grab):** A device which travels along a lifeline and automatically engages a line and lock to prevent an employee from falling.

**Fall restraint system:** A fall protection method that prevents employees from approaching an edge. With a properly constructed fall restraint system, employees are not in danger of a free fall should they trip or become unconscious. In situations where exposure to a fall hazard cannot be prevented, always use a fall arrest system.

**Jobsite:** A 360° area within which a worksite is contained.

**Worksite:** The immediate site where a task is conducted within a jobsite.

### Implementation Responsibilities

All electric maintenance and construction (EM&C), general construction, electric transmission (ET), and restoration area superintendents must ensure that the supervisors in their areas conduct tailboards on this procedure.

### Governing Document

NA

### Compliance Requirement/Regulatory Commitment

[American National Standards Institute \(ANSI\)](#)

[California Code of Regulations, Title 8, "Industrial Relations"](#)

[California Occupational Safety and Health Administration \(Cal/OSHA\)](#)

### Reference Documents

PG&E Courses:

- Safety at Heights – Authorized Person
- Safety at Heights – Competent Person
- Safety at Heights – Qualified Person



## Slope Safety

**Reference Documents,**  
*Continued*

Safety Engineering and Health Services (SEHS) Manuals:

- [Safety at Heights Reference Manual](#)
- [Safety at Heights User Guide M62-1073](#)
- [Safety Equipment Guide](#)

[SEHS Safety Tailboard, "Safety in the Field – Slope Safety Awareness"](#)

[Utility Standard Practice \(USP\) 22, "Safety and Health Program"](#)

**Appendices**

NA

**Attachments**

NA

**Document Recision**

NA

**Approved By**

Charles Gebhardt, Manager

**Document Owner**

Jerry Meleski, Supervisor

**Document Contact**

Tim Combs (TJCF)  
Senior Work Methods Specialist  
(209) 662-4499

**Revision Notes**

Where?	What Changed?
NA	This is a new document.

## **APPENDIX O**

### **Topcock Remedy Biological Hazards**

## Appendix P

### Biological Hazard Information Supplement

Topock Groundwater Remedy (PIVOX, Construction Health and Safety Plan, 2015)

---

## Biological Hazards and Controls

### Spiders

Spiders are frequently encountered in or near well monuments, inside sheds, or anywhere protected from the elements. Be very careful when working around these areas where spiders may be established. Take proper precautions-wear gloves and pay attention to where you are working.

If a person is bitten by a spider, clean the site well with soap and water. Apply a cool compress over the bite location and keep the affected limb below heart level, if possible. Aspirin or Tylenol may be used to relieve minor symptoms. **DO NOT** cut the wound or apply a tourniquet. If the wound is painful, seek medical attention immediately, or call the Poison Control Center at 1-800-222-1222.

Try to identify the type of spider: note color, size, patterns, and markings. The main spiders of concern in the Mojave area are the Black Widow and Brown Recluse.

#### **Black Widow (*Lactrodectus mactans*)**

The black widow spider is easily identified by its shiny black body and red, hour-glass marking on the underside of its abdomen. The venom of the black widow spider is 15 times as toxic as the venom of the Prairie Rattlesnake. But only a minute amount of the toxin is injected with a single bite by the spider, so they are rarely fatal.

The bite itself is often not painful and may go unnoticed, but the poison injected by the Black Widow bite can cause abdominal pain similar to appendicitis as well as pain to muscles or the soles of the feet. Other symptoms include alternating salivation and dry-mouth, paralysis of the diaphragm, profuse sweating and swollen eyelids.

Persons younger than 16 and older than 60, especially those with a heart condition, may require a hospital stay. (Heart and lung failure may result in death.) A physician can give specific antivenin or calcium gluconate to relieve pain. Healthy people recover rapidly in two to five days.

#### **Desert Recluse (*Loxosceles deserta*)**

The abdomen of the brown recluse spider is uniformly colored, although the coloration can range from light tan to dark brown, and is covered with numerous fine hairs that provide a velvety appearance. The long, thin, brown legs also are covered with fine hairs, but not spines. Brown recluse spiders are also commonly referred to as "fiddleback" spiders or "violin" spiders because of the violin-shaped marking on the top surface of the cephalothorax (fused head and thorax). However, this feature can be very faint depending on the species of recluse spider, particularly those in the southwestern U.S., or how recently the spider has molted.

Adult brown recluse spiders have a leg span about the size of a quarter. Their body is about 3/8 inches long and about 3/16 inches wide. Males are slightly smaller in body length than females, but males have proportionally longer legs. Both sexes are venomous. The brown recluse spider is not aggressive, and it normally bites only when crushed, handled or disturbed. Some people have been bitten in bed after inadvertently rolling over onto the spider. Others have been bitten after accidentally touching the spider when cleaning storage areas. Some bites occur when people put on seldom used clothing or shoes inhabited by a brown recluse.

The physical reaction to a brown recluse spider bite depends on the amount of venom injected and an individual's sensitivity to it. Some people are unaffected by a bite, whereas others experience immediate or delayed effects as the venom kills the tissue (necrosis) at the site of the bite. Many brown recluse bites cause just a little red mark that heals without event.

Initially, the bite may feel like a pinprick or go unnoticed. Some may not be aware of the bite for 2 to 8 hours. Others feel a stinging sensation followed by intense pain. Infrequently, some victims experience general systemic reactions that may include restlessness, generalized itching, fever, chills, nausea, vomiting, or shock. A small white blister usually initially rises at the bite site surrounded by a swollen area. The affected area enlarges and becomes red, and the tissue is hard to the touch for some time. The lesion from a brown recluse spider bite is a dry, blue-gray or blue-white,

irregular sinking patch with ragged edges and surrounding redness--termed the "red, white, and blue sign." The lesion usually is 1½ inches by 2¾ inches or smaller.

#### **Tarantula (g. *Aphonopelma*)**

The tarantula, the largest Mojave desert spider (body, 2 to 3 inches; 4 inch legs), is not poisonous to humans but its bite can be painful. They inhabit burrows, but freely roam. They are reluctant to bite humans and their venom is usually no worse than a bee sting. Tarantulas also release bristles from their abdomen for self-defense. The bristles, while not venomous, can be highly irritating to the skin and mucus membranes. If a person receives tarantula bristles, wash the effective area thoroughly with soap and water. Use an eyewash and seek medical attention if receiving bristles to the eye.

#### **Snakes**

Mojave-area snakes typically are found in underbrush, rock ledges, shady spots on hot days, and sunny rock shelves on cool mornings. If you encounter a snake, stay calm and look around; there may be other snakes. If it is apparent the snake is a rattlesnake, or if an identification cannot be made, turn around and walk away on the same path you used to approach the area.

Notify a project biologist whenever a snake has been encountered, regardless of whether the snake could be identified. Do not attempt to pick up or otherwise move a snake that may be in a work area or on an access/travel path. Instead, stop work to allow the snake to leave on its own, and/or notify a project biologist.

If a person is bitten by a snake, wash and immobilize the injured area, keeping it lower than the heart if possible. Seek medical attention immediately and contact the Poison Control Center at 1-800-222-1222. **DO NOT** apply ice, cut the wound, or apply a tourniquet. Try to identify the type of snake: note color, size, patterns, and markings.

#### **Mojave Rattlesnake (*Crotalus scutulatus*)**

The Mojave rattlesnake (Figure 1), also known as the Mojave Green Rattlesnake, is the most dangerous of rattlesnakes in the area. Its venom, about 16 times more powerful than that of the Sidewinder rattlesnake (see below), attacks both the nervous system and the bloodstream. These snakes are not known to be aggressive, but are known to stand their ground rather than to flee from perceived danger.

It looks similar to a diamondback rattlesnake, having diamond shapes along its back. Its color will vary from green-gray to yellowish tones. Adults range from 2-4 feet in length. The creosote bush (see Figure 2), found in the 2,000 to 4,000 foot elevation is the primary, but not the only, habitat of this snake.

They can be identified by their triangular-shaped head and diamond-shaped markings along their body, and of course, rattles. They are brown in color in the lower elevations and darken to a green in the higher regions near the mountains. It seems to prefer desert flats over hilly or canyon habitat. This species is active from April until September. It forages actively in the open and under bushes.

Figure 1 – Mojave Rattlesnake





Figure 2 – Typical Creosote Brush Habitat of the Mohave Rattlesnake



**Sidewinder rattlesnake (*Crotalus cerastes*)**

The sidewinder rattlesnake is most abundant in desert washes and flats with shrub cover and wind-blown sand, and especially at the bases of bushes partially buried in sand. This snake is active from mid-spring to early fall, but activity may be restricted during the hottest part of the summer. It is an active forager, but it also waits under bushes for prey, partially buried. It may occasionally use mammal burrows or surface cover objects.

**Other venomous snakes**

Two other snakes, the Speckled Rattlesnake and the Timber Rattle-snake may also be encountered, and excepting color variations and size, are very distinguishable as belonging to the rattlesnake family.

**Field Identification – Rattlesnakes**

By comparing Figure 1 with Figure 3, it can be seen the most distinguishing features in identifying rattlesnakes are the triangle-shaped head, and a less-pronounced tapering of the tail with whole or remnant rattles. Do not rely on the “buzz” of the rattles for identification, they are sometimes lost, or not deployed!

Figure 3 – A non-venomous gopher snake.



**Mammals and Associated Hazards**

The only predatory mammal in the area is the mountain lion, although mountain lions are rare in the Topock area. While generally wary of human activities, and seldom prone to attack, they will engage in stalking behavior, particularly for unaccompanied individuals. Attacks are most likely when they have the clear advantage of surprise, or rapid overpowering of their target.

Other mammals such as skunks, rats, bats, coatimundis, coyotes, foxes, raccoons, are present and are often not afraid of humans, particularly if poor food-waste practices draw their attention. Approaching “friendly” animals, juveniles,

or injured animals is particularly dangerous. These animals are sometimes found in open holes and trenches, and are particularly active at night, or cooler times of the day.

Being bitten can potentially result in rabies, and/or infections. Observations of the animal's behavior, and the carcass if safely available, will be important in the physician's evaluation regarding whether to implement prophylactic rabies treatment.

Hanta Virus or Four Corners disease, is a debilitating disease that may be fatal. It is associated with airborne exposure to fecal residue of rodents. Inactive areas where rodent activities are in evidence (pellet-like feces, shredded nesting materials) should be treated as Hanta virus suspect and precautions taken to prevent air-borne dissemination of dust bearing the virus. Use of wet methods for clearing the area will provide dust control to keep surfaces from shedding dust. Do not use dry sweeping, or pressurized air. Best practice is to use a mixture of soap, water and bleach applied by appropriate sized sprayer. "HEPA" filter respiratory protection is recommended during cleaning.

### **Bees, Stinging Insects, and Scorpions**

Bee and other stinging insects may be encountered almost anywhere and may present a serious hazard, particularly to people who are allergic. Personnel are to watch for and avoid nests, and keep exposed skin to a minimum. Personnel known to be allergic should also carry sting kit, and inform the SSO and immediate coworkers, who may be called to assist in the event of a sting and allergic response. If a stinger is present, remove it carefully with tweezers. Wash and disinfect the wound, cover it, and apply ice. Watch for allergic reaction; seek medical attention if a reaction develops.

Mosquitoes breed in open still water and will be uncommon unless rain events or unusual factors contribute to their propagation. They carry a number of infectious diseases in their saliva. If identified or suspected, DEET and similar class of mosquito repellents are effective in minimizing bites to exposed skin. Mosquito borne diseases recognized in California include:

- Chikungunya
- Dengue
- Malaria
- Mosquito-Borne Encephalitis/Encephalomyelitis
- Rift Valley Fever
- West Nile virus

The Striped Bark Scorpion is found in areas with a lot of cracks where it will hide. It is an active forager that does not burrow. It is distinctly associated with dead vegetation. During periods of hot weather, scorpions may move into living areas to escape the high temperatures. Scorpion behavior is non-aggressive, unless physically threatened.

Figure 4 - Striped Bark Scorpion



Scorpions have two pincers, 8 legs and an elongated body with a tail composed of segments. The last tail segment contains the stinger (also termed a telson) that transmits a toxin to the recipient of a sting. Scorpions may sting more than once; the stinger, located at the end of the tail segment is usually not lost or left in the person's tissue after a sting.

The sting is very a painful, but has a minor medical significance for healthy humans. Besides being painful a person who has been stung by a scorpion may feel a tingling, burning or numbing sensation at the sting site.

The reaction at the sting site may appear mild. However, infrequently, a person experiencing a serious reaction may develop severe symptoms throughout the body. Severe symptoms include widespread numbness, difficulty swallowing, a thick tongue, blurred vision, roving eye movements, seizures, salivation, and difficulty breathing. These symptoms constitute a medical emergency. Death may occur. Antivenom therapy is available.

1. Wash the sting with soap and water and remove all jewelry because swelling of tissue may impede the circulation if it not allowed to expand (for example, a sting on a finger that has a ring surrounding it).
2. Apply cool compresses, usually 10 minutes on and ten minutes off of the site of the sting.
3. Acetaminophen (Tylenol) 1-2 tablets every 4 hours may be given to relieve pain (usually not to exceed 3g per 24 hours). Avoid aspirin and ibuprofen (Advil, Motrin) because they may contribute to other problems.
4. Antibiotics are not helpful unless the sting area become secondarily infected.
5. Do not cut into the wound or apply suction.

Many scorpion stings can be prevented by taking precautions such as shaking out clothing and shoes to dislodge any scorpions, wearing clothing that covers the body (for example, wearing gloves and tucking in pant legs into boots may limit exposure). Many pesticides that are commercially used outside on homes may make some scorpions sluggish and easier to kill before they can sting. In addition, pesticides may markedly reduce the food source of scorpions.

If a scorpion is seen or felt on the skin, it is better to brush it off quickly instead of slapping at it because the scorpion will likely sting if the slap does not kill it.

Scorpions glow (fluoresce) under UV light (black light), so if a person is doing tasks in areas where scorpions might reside (dark areas like a closet or underneath a porch), people can use a black light to find them before they sting. This technique can be used at night when scorpions are more active and may be found on the floors or walls.

### **Bloodborne Pathogens**

Exposure to bloodborne pathogens may occur when rendering first aid or CPR, or when coming into contact with landfill waste or waste streams containing potentially infectious material. Exposure controls and PPE are required per recommendation of Medical Professional. Hepatitis B vaccination must be offered before the person participates in a task where exposure is a possibility.

All site H&S equipment must include a bloodborne pathogen kit, to be used when rendering first aid, and H&S personnel expected to serve as first responders are to be trained in the use of the bloodborne pathogen kit.



## Protection from Valley Fever

Valley fever is an illness caused by a fungus found in the soil in many parts of California, especially the Central Valley and Central Coast. For some, it can be serious and even fatal. Workers who work outdoors are especially at risk if they dig or disturb soil, operate heavy machinery, or work in windy conditions without taking steps to prevent valley fever.

### Information for Employers

- **Employers have a legal responsibility to immediately report to Cal/OSHA any serious injury or illness, or death (including any due to Valley Fever) of an employee occurring in a place of employment or in connection with any employment. Employers also have responsibilities to control workers' exposure to hazardous materials.**
- Applicable regulations with regard to Valley Fever protection and exposure can be found in the California Code of Regulations, Title 8, sections
  - [Section 342](#) (Reporting Work-Connected Fatalities and Serious Injuries),
  - [Section 3203](#) (Injury and Illness Prevention),
  - [Section 5141](#) (Control of Harmful Exposures),
  - [Section 5144](#) (Respiratory Protection) and
  - [Section 14300](#) (Employer Records-Log 300).
- Construction employers must train workers on Valley Fever prevention in counties where Valley Fever is highly endemic including but not limited to including, but not limited to, the Counties of Fresno, Kern, Kings, Madera, Merced, Monterey, San Joaquin, San Luis Obispo, Santa Barbara, Tulare, and Ventura. Other counties may be added to this list, depending on Valley Fever rates in future years.



## What is Valley Fever?

Valley Fever is caused by a microscopic fungus known as *Coccidioides immitis* which lives in the top two to 12 inches of soil in many parts of the state. When soil is disturbed by activities such as digging, driving, or high winds, fungal spores can become airborne and potentially be inhaled by workers. Populations with more than 20 cases annually of Valley Fever per 100,000 people are considered highly endemic.

While the fungal spores are more likely to be present in the soils of the Central Valley, they may also be present in other areas of California. The map below shows the areas with the greatest incidence of reported human Valley Fever cases. Work-related cases of Valley Fever at solar installation plants in the Central Valley have drawn attention to the health risks faced by California workers whose jobs may expose them to fungal spores found in soil.

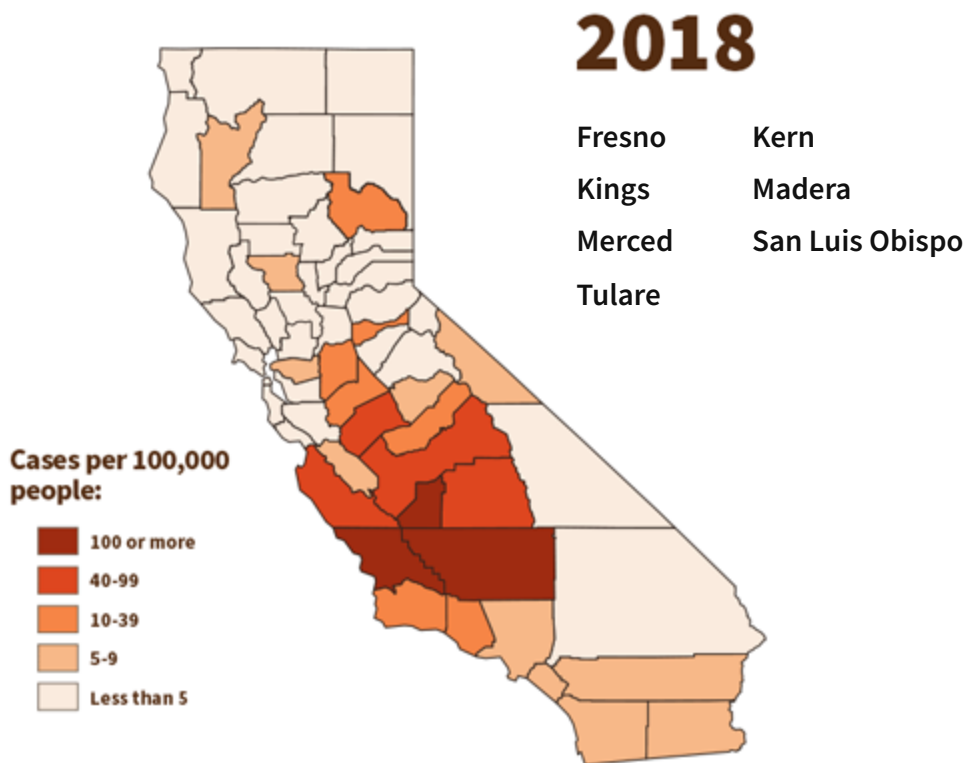

map source: [CDPH Valley Fever website portal](#)

## How can Valley Fever be Prevented?

While there is no vaccine to prevent Valley Fever, the following steps are important to take in order to limit risk:

- Determine if your worksite is in an endemic area.

- For employers in the construction industry, follow the requirements to train workers in [labor code section 6709](#).
- Adopt site plans, controls, and work practices that reduce workers' exposure, which may include:
  - Minimize the area of soil disturbed.
  - Use water, appropriate soil stabilizers, and/or re-vegetation to reduce airborne dust.
  - Stabilize all spoils piles by tarping or other methods.
  - Provide enclosed air conditioned cabs for vehicles that generate dust and make sure workers keep windows and outside air vents closed.
  - Suspend work during heavy winds.
  - Keep workers upwind of digging and other dust-producing activities, such as grading, driving, dumping soil, drilling, or blasting.
  - Use vacuums equipped with HEPA filters, water, wet towels, or other wet methods to clean soiled equipment, tools, and surfaces. Do not use compressed air, dry sweeping, or other methods that create dust when cleaning.
  - Keep break areas, eating areas, and sleeping quarters, if provided, clean and protected from sources of dust.
- When exposure to dust is unavoidable, provide NIOSH-approved respiratory protection with particulate filters rated as N95, N99, N100, P100, or HEPA. Employers must develop and implement a respiratory protection program in accordance with Cal/OSHA's Respiratory Protection standard (8 CCR 5144). Face coverings and masks do not protect against Valley Fever.
- Take measures to reduce transporting spores offsite, such as:
  - Clean tools, equipment, and vehicles safely before transporting offsite.
  - At dusty worksites, provide coveralls and change rooms, and showers where possible. Ensure workers change into clean clothes and shoes before leaving the worksite.
- Identify a health care provider for occupational injuries and illnesses who is knowledgeable about the diagnosis and treatment of Valley Fever
- Train workers and supervisors about the risk of Valley Fever, the work activities that may increase the risk, and the measures used onsite to reduce exposure. Also train on how to recognize Valley Fever symptoms.
- Encourage workers to report Valley Fever symptoms promptly to a supervisor. Not associating these symptoms with workplace exposures can lead to a delay in appropriate

diagnosis and treatment.

## What work activities increase the risk of Valley Fever?

When fungal spores are present, wind and any work activity that disturbs the soil, such as digging, grading or other earth moving operations, or vehicle operation on dirt roads, can cause the spores to become airborne, therefore increasing the risk of Valley Fever. All workers on sites where the fungus is present, and who are exposed to dusty conditions and wind-blown dusts are at increased risk of becoming infected.

- Construction workers and other workers on construction sites, including road building and excavation crews
- Archeologists
- Geologists
- Wildland firefighters
- Military personnel
- Workers in mining, quarrying, gas and oil extraction jobs
- Agricultural workers \*

\* Cultivated, irrigated soil may be less likely to contain the fungus compared to undisturbed soils.

## What should employers do if a worker reports Valley Fever symptoms?

- Report all hospitalized cases and deaths to Cal/OSHA.
- Complete the ["Employer's Report of Occupational Injury or Illness" \(Form 5020\)](#) for each suspected occupational Valley Fever illness.
- Send the worker to a workers' compensation healthcare provider or occupational medicine clinic whose staff is knowledgeable about Valley Fever. Alert the provider or clinic to the possibility that the employee was exposed to dusts that may contain coccidioides spores. Physicians must submit a ["Doctor's First Report of Occupational Injury or Illness" \(Form 5021\)](#) for each employee evaluated for occupational Valley Fever.
- [Record all cases](#) on the Cal/OSHA Log 300.

## More Resources ...

---

- [California Department of Public Health Valley Fever webpage](#)

- [Preventing Work-Related Valley Fever](#)
- [VALLEY FEVER: Tailgate Training Guide for California Construction Workers](#)
- [FIEBRE DEL VALLE: Guía de Capacitación Breve para Trabajadores de la Construcción de California](#)
- [Kern County Public Health Services Department Valley Fever webpage](#)
- [Centers for Disease Control and Prevention Valley Fever webpage](#)

*Updated: April 2022*



### 1. ABOUT THIS GUIDE

This guide will help you train workers on Valley fever. It covers the 8 topics required for construction worker Valley fever training under 2019 California legislation, AB 203.

This training is required for employees working in 11 counties where work activities disturb the soil. These counties have the highest rates of Valley fever: Fresno, Kern, Kings, Madera, Merced, Monterey, San Joaquin, San Luis Obispo, Santa Barbara, Tulare, and Ventura. Other counties may be added to this list, depending on Valley fever rates in future years.

You can use this guide with the [“Preventing Work-Related Valley Fever” fact sheet](https://bit.ly/VfWorkFacts) (bit.ly/VfWorkFacts). ***Instructions for trainers using this guide are in bold italics.*** Answers to questions are in the shaded boxes.

### 2. INTRODUCTION

**Say:** Today we are going to talk about Valley fever, which is a known hazard for construction workers in certain parts of California. We are doing Valley fever training because you may work in one of the 11 counties with the highest rates of this illness. This training is also required by law.

**Ask:** What do you all already know about Valley fever?

**Let workers respond and then read:**

Valley fever is an illness that usually affects the lungs. It is caused by a fungus that lives in the soil in many parts of California.

- When the soil is disturbed by digging, vehicles, or wind, the fungus spores get into the air. Spores are like tiny seeds that are too small to see.
- People can breathe the spores into their lungs and get Valley fever.
- Valley fever affects people differently. While many people who get Valley fever have no symptoms or only very mild ones, others can get very sick or even die.
- Valley fever is not a contagious disease - it cannot be spread from person to person. It is almost always caused by breathing in the fungus from dust in the air.

### 3. VALLEY FEVER SYMPTOMS

**Ask:** What are some symptoms of Valley fever?

**Let workers respond; acknowledge correct answers, then say:**

More than half of people (about 60%) infected with Valley fever have no symptoms, and their bodies will fight off the infection naturally. People who get sick usually develop symptoms one to three weeks after breathing in the fungus. Valley fever usually infects the lungs, and some people can develop respiratory symptoms or pneumonia. Common Valley fever symptoms can be mistaken for a cold, influenza, or pneumonia, but last longer than one week. They include:

Fatigue (tiredness)	Night sweats	Weight loss
Cough	Muscle or joint pain	Headache
Difficulty breathing	Chest pain	Rash
Fever		

**Ask:** How long do Valley fever symptoms last?

**Say:**

Valley fever can affect people in different ways. Some people with Valley fever may only have mild symptoms that get better on their own within a few weeks. However, some symptoms, especially fatigue, can take longer to go away and can last for several months.

In rare cases, Valley fever can cause severe infections in the lungs or in other parts of the body. This more severe form of Valley fever can cause infections in the skin, bones, joints, or brain. People with severe Valley fever may need to be hospitalized, and they will likely need follow-up medical care from a doctor for several months or even years. In very rare instances, severe Valley fever can be fatal.

#### 4. VALLEY FEVER RISK

**Ask:** Who can get sick?

**Let workers respond; acknowledge correct answers, then say:**

Anyone can get Valley fever, even healthy adults and children. Living, working, and even driving around outside in dust can put you at risk.

**Ask:** Are any people more likely to get very sick with Valley fever?

**Let workers respond, then say:**

Some people have a higher risk of getting very sick if they get Valley fever. These include:

- Older adults (60 years and older), pregnant women, and people with diabetes.
- Certain racial/ethnic groups: African Americans and Filipinos.
- People with health conditions that weaken your immune system such as cancer, HIV, autoimmune illnesses, chemotherapy or steroids treatment, and organ transplants.

## 5. VALLEY FEVER TREATMENT & OUTCOMES

**Ask:** How is Valley fever diagnosed and treated?

**Let workers respond, then say:**

Valley fever can be diagnosed with a blood test or other laboratory test. Although specific medications called “antifungals” are available to treat fungal infections like Valley fever, not everyone needs this kind of treatment.

- It is **very important** that you report symptoms that might be Valley fever as soon as you suspect it, so that a doctor familiar with Valley fever can evaluate you, confirm if it is Valley fever, and determine if you need treatment.
- Be sure to tell your doctor if, in the month before you got sick, you were in an area where Valley fever has been reported and if you were exposed to dirt or dust in that area, for example if you were on a worksite where digging was occurring, or if you were outdoors during a dust storm.
- Your doctor will consider a number of factors when deciding if you need testing, treatment, or neither.
- Some people with Valley fever get better without treatment because their bodies will fight off the infection naturally.
- Antifungal medications used to treat Valley fever are usually given to people who may need to take them for months or even years because of severe disease. Not everyone with Valley fever needs to take these medications.

## 6. WHERE THE FUNGUS MAY BE PRESENT

**Ask:** How do you know if the fungus is present in the soil?

**Let workers respond, then say:**

Fungus in the soil is too small to see. There is no reliable way to test the dirt around a worksite for Valley fever. Valley fever is most common in California in the Central Valley and Central Coast. But best practice is to prevent dust from getting in the air on all jobsites.

*This map shows where people who had Valley fever lived, not where they worked.*

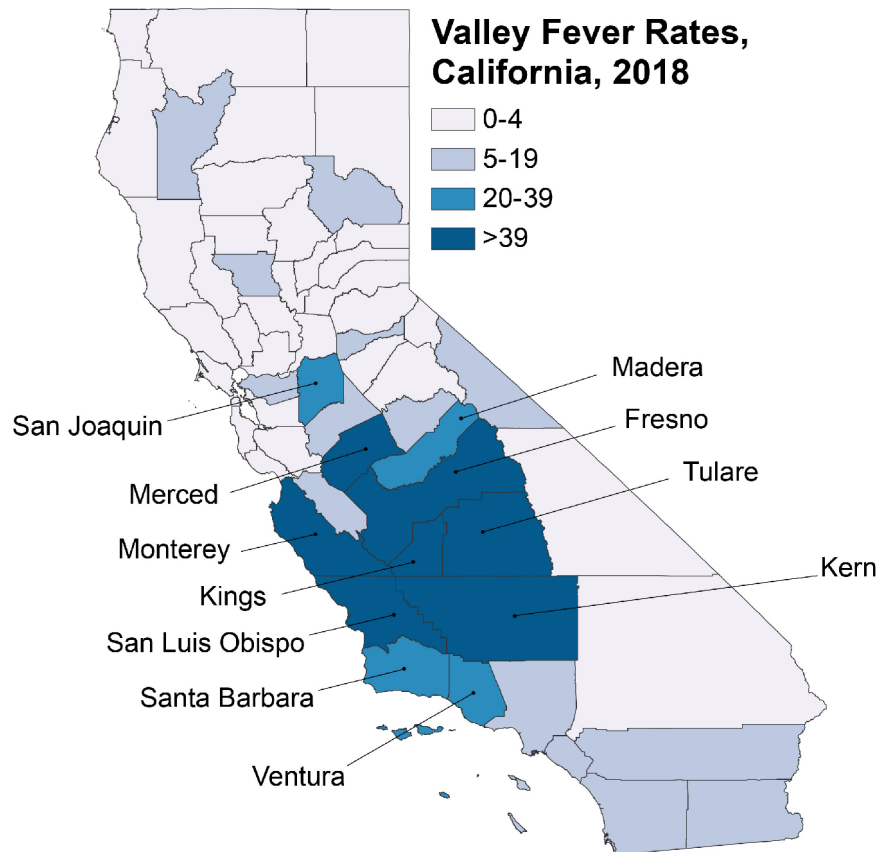

*Rates of Valley fever cases reported per 100,000 population. Darkest colored counties had the highest rates of Valley fever.*

## 7. CONTROL MEASURES

**Ask:** What are some things we can do to prevent worker exposure to the Valley fever fungus?

**Let workers respond; acknowledge correct answers, then say:**

- Use enough water on open dirt areas to keep dust down.
- Avoid work during dust storms or high winds.
- Stay upwind of digging and other dust-producing activities, such as dumping soil, drilling, or blasting.
- Heavy equipment should have enclosed cabs, air conditioning, and filters that clean the air coming in. Operators should have a way to communicate without opening windows.
- Use water to clean dusty equipment whenever you can.
- Keep dust away from your food and drinks. Take dusty clothes off and wash up before you take a break or eat lunch.
- Change into clean clothes and shoes before leaving a dusty job site. Keep dusty clothes and shoes in a plastic bag.
- Shower and wash your hair at work or as soon as you get home.
- If controlling dust is not possible, workers should be protected by respirators with particulate filters under a respirator program. Bandanas and simple dust masks are not protective against Valley fever.\*

\* See Resources on Page 10 for more info on respirator programs.

## 8. AT YOUR JOBSITE (IF APPLICABLE)

***It's important for employees to know what protections should be in place so they can speak up if things don't go the way they are supposed to. Fill in the following items before you do the training.***

**Say:** On this job the things we'll do to protect you from Valley fever are:

Using water trucks (describe where and how often they will go by):

---

---

---

Using water hoses when digging (describe how they will be used):

---

---

---

Workers will need to wear a respirator for these tasks:

---

---

---

Include other controls specific to your jobsite:

---

---

---

**Say:** It is important to keep workers safe. If anyone sees dust that is not being controlled, let \_\_\_\_\_ know right away.

***(Fill in name and number of supervisor in charge of dust control.)***

## 9. PRACTICE SCENARIO

**Say:** It's a hot, windy day at a new housing development. A trenching crew is installing a sewer main while a surveyor measures the location of property lines next to them. The trenching crew was trained on Valley fever prior to beginning excavation. The surveyor was not trained. Before digging, the laborers in the trenching crew put on their respirators and the heavy equipment operator confirmed with the foreman that his cab had clean HEPA filters. During the excavation, no water was used for dust suppression. The surveyor, who was downwind, was bothered by the dust. She shouted for the digging to stop until the wind died down but could not be heard, so she kept working.

**Ask:** What went right in this scenario?

**Let workers respond; acknowledge correct answers, then say:**

- The trenching crew was trained on Valley fever prevention.
- The crew had respirators.
- The heavy equipment operator was in an enclosed cab with clean HEPA filters.
- The surveyor tried to speak up about the dust.

**Ask:** What could have been done to prevent the surveyor from possible exposure to Valley fever?

**Let workers respond; acknowledge correct answers, then say:**

- EVERYONE in a dusty area should be trained on Valley fever before working.
- Water should be used to keep dust down.
- The work should have been postponed until it was less windy.
- The supervisor should have made sure no one was downwind.
- The surveyor should have been included in the respirator program so she would be able to wear a respirator.



## 10. WORKER ACTIONS

**Ask:** What can workers do if they are concerned about Valley fever?

**Let workers respond; acknowledge correct answers, then say:**

There are a few important things you as workers can do:

- Talk with your supervisor, safety manager, or union representative if you have any concerns about dust control, respiratory protection, or other health or safety issues.
- If you have symptoms that may be Valley fever, ask to see an occupational health doctor under workers' compensation. Tell the doctor where you work and what you do.

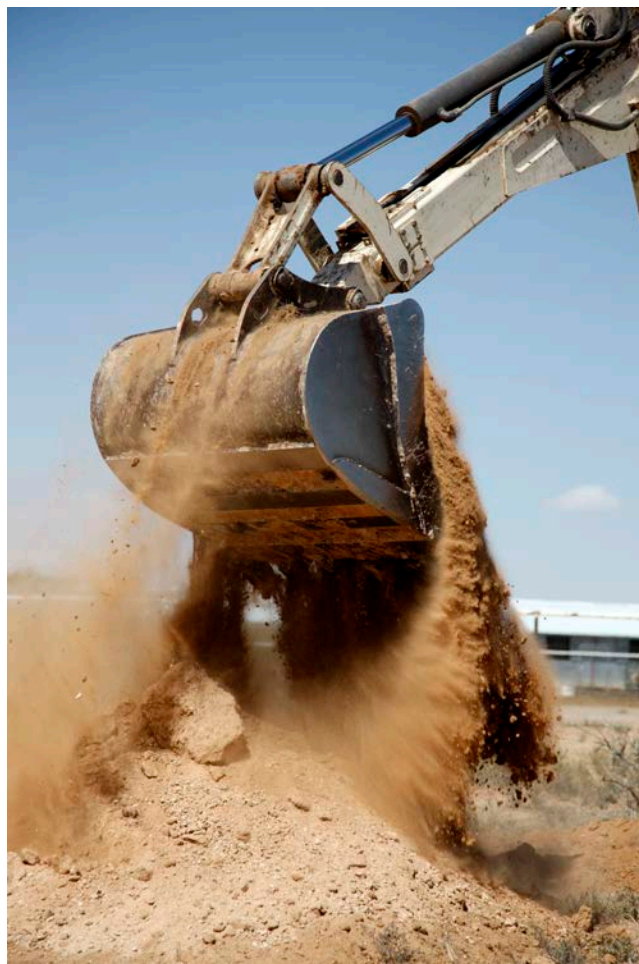

## RESOURCES & EMPLOYER ACTIONS

### WHAT EMPLOYERS CAN DO

- Include Valley fever in your Injury and Illness Prevention Program.
- Train workers on Valley fever prevention and symptoms.
- Check out the California Department of Public Health's resources on the [CDPH work-related Valley fever web page](http://www.cdph.ca.gov/workrelatedvalleyfever) ([www.cdph.ca.gov/workrelatedvalleyfever](http://www.cdph.ca.gov/workrelatedvalleyfever)).
- See Cal/OSHA's guidance on employer responsibilities for preventing Valley fever and what to do if workers get sick. Includes guidance on respirator programs. Visit [Cal/OSHA Valley fever guidance](http://www.dir.ca.gov/dosh/valley-fever-home.html) ([www.dir.ca.gov/dosh/valley-fever-home.html](http://www.dir.ca.gov/dosh/valley-fever-home.html)).
- Contact Cal/OSHA Consultation for free help with Valley fever prevention. Call 1-800-963-9424 or [email Cal/OSHA consultation](mailto:infocons@dir.ca.gov) ([infocons@dir.ca.gov](mailto:infocons@dir.ca.gov)).
- Visit the [CDPH general Valley fever web page](http://www.cdph.ca.gov/valleyfever) for more information about Valley fever illness. ([www.cdph.ca.gov/valleyfever](http://www.cdph.ca.gov/valleyfever)).
- Call or email your local health department's communicable disease contact for information on Valley fever in areas where you will be working. Find your local health department on the [CDPH list of local health departments](http://www.cdph.ca.gov/Pages/LocalHealthServicesAndOffices.aspx) ([www.cdph.ca.gov/Pages/LocalHealthServicesAndOffices.aspx](http://www.cdph.ca.gov/Pages/LocalHealthServicesAndOffices.aspx)).



Special thanks to the **State Building and Construction Trades Council** for their generous collaboration.

---

*To obtain a copy of this document in an alternate format, please call (510) 620-5757 (CA Relay Service: 711). Please allow at least ten (10) working days to coordinate alternate format services.*

California Department of Public Health, Occupational Health Branch  
850 Marina Bay Parkway, P-3, Richmond, CA 94804  
Phone: (510) 620-5757 | [www.cdph.ca.gov/ohb](http://www.cdph.ca.gov/ohb)

TAILGATE SAFETY TRAINING SIGN-IN SHEET

***Make copies of this sign-in sheet to use each time you deliver the training. Save the ones you use at trainings to keep track of which workers were trained.***

Training Date: \_\_\_\_\_ Job-site Location: \_\_\_\_\_

Training Topic(s): \_\_\_\_\_

Training Done By: \_\_\_\_\_ Signature: \_\_\_\_\_

**Names of Workers Attending**

_____	_____
_____	_____
_____	_____
_____	_____
_____	_____
_____	_____
_____	_____
_____	_____
_____	_____
_____	_____
_____	_____
_____	_____
_____	_____
_____	_____
_____	_____
_____	_____
_____	_____
_____	_____
_____	_____
_____	_____
_____	_____
_____	_____
_____	_____

## **APPENDIX P**

### **Contaminants Of Concern Primary Health Hazards and OELs**

**Chemicals of Concern Primary Health Hazards**

Mixture/Chemical	Physical and Chemical Properties	Routes of Exposure	Target Organs	Symptoms	IARC <sup>i</sup> or EPA Carcinogen	EXPOSURE LIMIT PEL/STEL/IDLH
<p align="center">Arsenic (Inorganic) (CAS No. 744-38-2)  Title 8 §5214</p>	<p align="center">Silver-gray or tin-white, brittle, odorless solid</p>	<p align="center">Inhalation, ingestion, skin and/or eye contact</p>	<p align="center">Liver, kidneys, skin, lungs. Lymphatic system</p>	<p align="center">Ulceration of nasal septum, dermatitis, gastrointestinal disturbances, peripheral neuropathy, respiratory irritation, hyperpigmentation of skin, potential occupation carcinogen</p>	<p align="center">Group 1 Yes</p>	<p align="center">CALOSHA PEL 0.01 mg/m<sup>3</sup> TWA  NIOSH REL C 0.002 mg/m<sup>3</sup> (15 minutes)  5 mg/ m<sup>3</sup> IDLH</p>
<p align="center">Asbestos</p>	<p align="center">White or greenish (chrysotile), blue (crocidolite), or gray-green (amosite) fibrous, odorless solids.</p>	<p align="center">Inhalation, ingestion, skin and/or eye contact</p>	<p align="center">Respiratory system, eyes</p>	<p align="center">Asbestosis (chronic exposure): dyspnea (breathing difficulty), interstitial fibrosis, restricted pulmonary function, finger clubbing; irritation eyes; [potential occupational carcinogen]</p>	<p align="center">Yes</p>	<p align="center">0.1 f/cc 1 f/cc 30 min. NA  Clearance - &lt; 0.01 f/cc</p>

**Chemicals of Concern Primary Health Hazards**

Mixture/Chemical	Physical and Chemical Properties	Routes of Exposure	Target Organs	Symptoms	IARC <sup>i</sup> or EPA Carcinogen	EXPOSURE LIMIT PEL/STEL/IDLH
<p align="center">Benzo (a) Pyrene (CAS No. 50-32-8)</p>	<p align="center">Black or dark-brown amorphous residue (Coal tar pitch volatiles)</p>	<p align="center">Ingestion or inhalation. It may cause irritation. When heated to decomposition it emits acrid smoke and toxic fumes of carbon monoxide and carbon dioxide.</p>	<p align="center">Eyes, skin, respiratory system, blood, central nervous system</p>	<p>Symptoms of exposure to this compound include mucous membrane irritation, dermatitis, bronchitis, cough, dyspnea, conjunctivitis, photosensitization, pulmonary edema, reproductive effects and leukemia. Contact with the skin may result in erythema, pigmentation, desquamation, formation of verrucae and infiltration. It may also cause keratoses which are relatively small, heaped-up, scaling, brown plaques on the skin, some of which may be fissured and may itch. Exposure to this type of compound may cause reddening and squamous eczema of the lid margins with only small erosion of the corneal epithelium and superficial changes in the stroma which disappear a month following exposure. Repeated exposure may cause sunlight to have a more severe effects on a person's skin and also an allergic skin rash. Aplastic anemia may also occur. Chronic exposure to the fumes and dust of this type of compound can cause discoloration of the cornea and epithelioma of the lid margin.</p>	<p align="center">Group 1 Yes</p>	<p align="center">CALOSHA PEL 0.2 mg/m<sup>3</sup> TWA  NIOSH REL 0.1 mg/m<sup>3</sup> TWA  80 mg/m<sup>3</sup> IDLH</p>
<p align="center">Carbon Monoxide (CAS No. 630-08-0)</p>	<p align="center">Colorless, odorless gas.</p>	<p align="center">Inhalation, skin and/or eye contact (liquid)</p>	<p align="center">Cardiovascular system, lungs, blood, central nervous system</p>	<p align="center">Headache, tachypnea, nausea, lassitude (weakness, exhaustion), dizziness, confusion, hallucinations; cyanosis; depressed S-T segment of electrocardiogram, angina, syncope</p>	<p align="center">No</p>	<p align="center">CALOSHA PEL 25 ppm TWA 200 ppm C  ACGIH TLV 5 ppm TWA  1200 mg/m<sup>3</sup> IDLH</p>

**Chemicals of Concern Primary Health Hazards**

Mixture/Chemical	Physical and Chemical Properties	Routes of Exposure	Target Organs	Symptoms	IARC <sup>i</sup> or EPA Carcinogen	EXPOSURE LIMIT PEL/STEL/IDLH
Chromium (as Cr(III)) (CAS No. 7440-47-3)  Chromium (as Cr(VI)) (CAS No. 133-82-0) CCR T8, §1532.2	Blue-white to steel-gray, lustrous, brittle, hard, odorless solid	Inhalation, ingestion, skin and/or eye contact	Eyes, Skin	Irritation eyes, Sensitization dermatitis	Group I Yes Cr(VI) only	CALOSHA PEL 0.5 mg/m <sup>3</sup> TWA 25 mg/m <sup>3</sup> STEL  2.5 ug/m <sup>3</sup> AL 5 ug/m <sup>3</sup> PEL
Crystalline Silica (CAS No. 14808-60-7)	Colorless, odorless solid	Inhalation, skin and/or eye contact	Eyes, respiratory system	Cough, dyspnea (breathing difficulty), wheezing; decreased pulmonary function, progressive respiratory symptoms (silicosis); irritation eyes; potential occupational carcinogen	Group 1 Yes	CALOSHA PEL 0.05 mg/m <sup>3</sup> TWA 0.025 mg/m <sup>3</sup> TWA Action Level (AL)
Dioxin (As 2,3,7,8-Tetrachlorodibenzo-p-dioxin (TCDD)) (CAS No. 1746-01-6)	Colorless to white, crystalline solid.	inhalation, skin absorption, ingestion, skin and/or eye contact	Eyes, skin, liver, kidneys, reproductive system	irritation eyes; allergic dermatitis, chloracne; porphyria; gastrointestinal disturbance; possible reproductive, teratogenic effects; In Animals: liver, kidney damage; hemorrhage; [potential occupational carcinogen]	Group 1 Yes	OEEHA REL 40 pg/m <sup>3</sup> (Chronic)

**Chemicals of Concern Primary Health Hazards**

Mixture/Chemical	Physical and Chemical Properties	Routes of Exposure	Target Organs	Symptoms	IARC <sup>i</sup> or EPA Carcinogen	EXPOSURE LIMIT PEL/STEL/IDLH
<p align="center">Hydrogen Sulfide (CAS No. 7783-06-4) IP: 10.46 eV</p>	<p>Colorless gas with a strong odor of rotten eggs. [Note: Sense of smell becomes rapidly fatigued &amp; can NOT be relied upon to warn of the continuous presence of H<sub>2</sub>S. Shipped as a liquefied compressed gas.]</p>	<p align="center">Inhalation, skin and/or eye contact</p>	<p align="center">Eyes, respiratory system, central nervous system</p>	<p>Irritation eyes, respiratory system; apnea, coma, convulsions; conjunctivitis, eye pain, lacrimation (discharge of tears), photophobia (abnormal visual intolerance to light), corneal vesiculation; dizziness, headache, lassitude (weakness, exhaustion), irritability, insomnia; gastrointestinal disturbance; liquid: frostbite</p>	<p align="center">No</p>	<p align="center">CALOSHA PEL 10 ppm TWA 15 ppm STEL 50 ppm C  NIOSH REL 10 ppm C  100 ppm IDLH</p>
<p align="center">Lead (CAS No. 7439-92-1)  Title 8 §1532.1</p>	<p align="center">A heavy, ductile, soft gray solid</p>	<p align="center">Inhalation, ingestion</p>	<p align="center">GI tract, CNS, kidneys, blood, gingival tissue</p>	<p align="center">Gastrointestinal disturbances, central nervous system depression, kidney damage, reproductive toxin &amp; red blood cell abnormalities</p>	<p align="center">Group 2A/B Yes</p>	<p align="center">CALOSHA PEL 0.05 mg/m<sup>3</sup> TWA  0.03 mg/m<sup>3</sup> AL</p>



**Chemicals of Concern Primary Health Hazards**

Mixture/Chemical	Physical and Chemical Properties	Routes of Exposure	Target Organs	Symptoms	IARC <sup>i</sup> or EPA Carcinogen	EXPOSURE LIMIT PEL/STEL/IDLH
Mercury (as Hg) (CAS No. 7439-97-6)	Silver-white, heavy, odorless liquid.	Inhalation, skin absorption, ingestion, skin and/or eye contact	Eyes, skin, respiratory system, central nervous system, kidneys	Irritation eyes, skin; cough, chest pain, dyspnea (breathing difficulty), bronchitis, pneumonitis; tremor, insomnia, irritability, indecision, headache, lassitude (weakness, exhaustion); stomatitis, salivation; gastrointestinal disturbance, anorexia, weight loss; proteinuria	Group 3	CALOSHA PEL 0.025 mg/m <sup>3</sup> TWA 0.1 mg/m <sup>3</sup> C  10 mg/m <sup>3</sup>
Polychlorinated biphenyl (PCB)  Chlorodiphenyl 54% (CAS No. 11097-69-1)	Colorless to pale-yellow, viscous liquid or solid (below 50°F) with a mild, hydrocarbon odor.	inhalation, skin absorption, ingestion, skin and/or eye contact	Skin, eyes, liver, reproductive system	irritation eyes, chloracne; liver damage; reproductive effects; [potential occupational carcinogen]	Group 1 Yes	CALOSHA PEL 0.5 mg/m <sup>3</sup> TWA [Skin]  NIOSH REL 0.001 mg/m <sup>3</sup>
Pentachlorophenol (m- CAS No. 87-86-5)	Colorless to white, crystalline solid with a benzene-like odor. [fungicide]	inhalation, skin absorption, ingestion, skin and/or eye contact	Eyes, skin, respiratory system, cardiovascular system, liver, kidneys, central nervous system	irritation eyes, nose, throat; sneezing, cough; lassitude (weakness, exhaustion), anorexia, weight loss; sweating; headache, dizziness; nausea, vomiting; dyspnea (breathing difficulty), chest pain; high fever; dermatitis	Group 1 Yes	CAL OSHA PEL 0.5 mg/m <sup>3</sup> TWA  IDLH 2.5 mg/m <sup>3</sup>

Chemicals of Concern Primary Health Hazards						
Mixture/Chemical	Physical and Chemical Properties	Routes of Exposure	Target Organs	Symptoms	IARC <sup>i</sup> or EPA Carcinogen	EXPOSURE LIMIT PEL/STEL/IDLH
Total Petroleum Hydrocarbons (TPH) - Diesel	Colorless liquid with a gasoline- or kerosene-like odor.	Inhalation, skin absorption, skin and/or eye contact ingestion	Eyes, skin, respiratory system, central nervous system	Eye irritation, central nervous system disorder, headache, dizziness, peripheral neuropathy, blood, immune system, lungs, skin and eyes.	No	ACGIH TLV 100 mg/m <sup>3</sup> TWA

<sup>i</sup> Group 1 – Carcinogenic to humans; Group 2A – Probably carcinogenic to humans; Group 2B – Possibly carcinogenic to humans; Group 3 – Not classifiable as to its carcinogenicity to humans; Group 4 Probably not carcinogenic to humans

## **APPENDIX Q**

### **PG&E ATV/UTV Guidance Documents**



# Utility-Terrain Vehicle (UTV) Guidelines: Contractor Frequently Asked Questions

Contractors are required to follow the updated PG&E operating guidelines for PG&E Class 1 and Class 2 Utility-Terrain Vehicles (UTV), including expanded training, safety controls and safety mechanisms. Non-compliance with these guidelines will be evaluated and could result in loss of contracting opportunities with PG&E.

**Effective July 16, 2020, before using a Class 1 UTV to complete work, all contractors must:**

- Upload into ISNetworld under “Owner/Client Specific Documents” their safety program for Class 1 UTV use and training curriculum specific to each make(s) and model(s) of the Class 1 UTV vehicle(s) used.
- Train and qualify Class 1 UTV operators on the make(s) and model(s) of vehicle(s) used, and upload training qualifications for each operator to ISNetworld; qualification criteria must meet or exceed the minimum expectations set by PG&E, and each operator will have to show competence in a knowledge and skill assessment. Minimum expectations provided in Appendix 1 of this document.
- To understand when it’s appropriate to request a UTV, use PG&E’s Decision Matrix provided in Appendix 2 of this document.
- To request a PG&E Class 1 UTV, use PG&E’s Class 1 UTV Approval Form provided in Appendix 3 of this document.

Please email [UtilityTerrainVehicleInfo@pge.com](mailto:UtilityTerrainVehicleInfo@pge.com) with additional questions regarding the use of UTVs.

**How do the updated requirements affect the March 17, 2020 off-highway utility vehicle stand down?**





The stand down related to off-highway utility vehicles may be lifted upon PG&E line-of-business vice president approval, along with SVP and Chief Safety Officer concurrence, on a case-by-case basis. PG&E’s contract workforce must use the request process detailed below, and with adherence required to newly implemented safety requirements around requesting and using Class 1 and Class 2 UTVs.

**What is a Class 1 Utility-Terrain Vehicle (UTV)?**

The term “Class 1 Utility-Terrain Vehicle” refers to both utility-terrain vehicles and recreational off-highway vehicles grouped together due to similar manufacturer specifications and PPE requirements.

Can-Am Units to be retrofitted with speed governors (orange Key Fob) at 25mph.

Examples of Class 1 UTVs are pictured to the right. Class 1 UTVs may be used with approval, required training and PPE if the vehicle meets all specifications outlined below.

Picture	Make/Model	People	Industry Current Classification	PG&E Classification
	Can-Am Defender Max XT HD10	4-person	ROV	Class 1
	Can-Am Defender XT-P HD10	2-person	ROV	Class 1
	Can-Am Maverick Trail	2-person	ROV	Class 1
	Kawasaki Pro DX EPS	2-person	UTV	Class 1





# Utility-Terrain Vehicle (UTV) Guidelines: Contractor Frequently Asked Questions

## Do I need approval from PG&E before using a Class 2 Utility-Terrain Vehicle (UTV)?

No. Class 2 UTVs are low speed golf carts style units designed for operation off the highway and have a maximum speed of 25 mph.

All Class 2 UTVs pictured to the right may be used if company training was completed before first use. Required minimum PPE, a hard hat, safety glasses, and any other PPE in the operator's manual, must be worn during use and the vehicle meets all specifications outlined below.

	Cushman 800	2-person	UTV	Class 2
	E-Z-GO Terrain 250	2-person	UTV	Class 2
	John Deere Gator	2-person	UTV	Class 2
	Polaris Gem E4	4-person	UTV	Class 2

## What is the process for a contractor to request a UTV?

Follow the steps below to receive approval from PG&E before using a UTV.

- 1) To understand if your project is eligible to use a Class 1 UTV, use PG&E's Decision Matrix provided in Appendix 2 and Appendix 3. Vendors may use their own decision matrix as long as it meets these PG&E minimum criteria.
- 2) If it is determined that a **Class 1 UTV** is required, complete the approval form in Appendix 3.
  - a) Return form to your superintendent or senior leadership for approval and submit with the project bid. Outside of the bidding process, contractor leadership should submit the form to a PG&E line of business leadership representative for approval.

## What UTV training do contractor UTV operators need to take?

Operators-in-training **must** complete the following prerequisites:

- Read the UTV manufacturer's operation and maintenance manual and recommended operating procedures.
- Complete your company's:
  - **Class 2 UTV** training if you're a first time Class 2 operator.
  - **Class 1 UTV** training specific to the model being used that includes classroom and hands-on operation familiarizing students with UTV capabilities and handling characteristics and:
    - Instruction by a qualified instructor.
    - The class must require students to pass a knowledge and skill assessment.
    - The knowledge and skill assessment used to qualify operators must, at minimum, meet the requirements provided in PG&E's Class 1 UTV knowledge and skill assessment provided in Appendix 1.
    - Operators must be requalified every 3 years.

## How does PG&E validate contractor training curriculum and UTV operator qualifications?

- Each PG&E line of business must add a training qualification (TQ) requirement in ISNetworld for their applicable contractors. A separate TQ must be created for each make/model of vehicle the contractor is providing training for.
- Contractor UTV training curriculum must be uploaded to ISNetworld with the company's UTV safety program in "Owner/Client Specific Documents."
- Contractor UTV knowledge and skill qualification assessments must be uploaded for each operator's training qualification and for each type of vehicle they are qualified to operate.
- PG&E will validate UTV training qualifications of contract employees by scanning ISNetworld badges prior to use. Only operators with valid UTV training qualifications in ISNetworld may operator Class 1 UTVs.



# Utility-Terrain Vehicle (UTV) Guidelines: Contractor Frequently Asked Questions

## What is the required personal protective equipment (PPE) for operating UTVs?

---

- Minimum PPE for Class 1 UTVs include a Department of Transportation (DOT) helmet for UTVs and goggles or eye visor attached to the helmet.
- Minimum PPE requirements for Class 2 low-speed vehicles include a hard hat and safety glasses.
- Other PPE items stated in the operator's manual of each specific vehicle are also required.

## What new safety features must UTVs have prior to use by PG&E workforce?

---

All Class 1 and Class 2 UTVs must meet the following specifications prior to use by the PG&E and contract workforce:

- Demonstrated engineered control-limiting speed to less than 30 mph and to not accelerate over 15 mph with an unfastened driver's seatbelt (speed governed)
  - Contractors utilizing Can-Am models: Can-Am models to be retrofitted with speed governors (must use orange Key Fob or other retrofitted control mechanism) at 25mph.
- Seat belt interlock system installed (if available by the manufacturer)
- Brightly colored three-point seat belt assemblies
- Cab doors or nets
- Eliminate the use of the front middle seat
- Installed rollover protection structure (ROPS)

## When are contractors and employees permitted to use a Class 1 UTV?

---

- The ability to use a pickup truck or other alternative, such as a snowcat, drone, foot or helicopter to complete a job must be thoroughly evaluated first.
- If terrain or conditions make a Class 1 UTV the best option to complete a job, a request may be submitted and approved.
- Written approval using Class 1 Pre-UTV Checklist and Safe Operating Limits criteria is required before use (Appendix 2 & 3).
- Class 1 UTV is the exception, not the norm.

## What company incidents occurred with UTVs?

---

PG&E and its contractors occasionally use off-road utility vehicles to access remote areas. However, serious safety incidents continue to occur, including two fatalities.

- **2020:** A vegetation management contractor crew was involved in an UTV incident, resulting in one fatality and two injured workers.
- **2019:** A two-person Electric Transmission Linemen crew could have been potentially injured when their off-highway vehicle lost the ability to brake while traveling downhill and rolled over multiple times.
- **2018:** An apprentice lineman was fatally injured in an off-highway vehicle accident near the Oak Bottom Marina while supporting the Carr Fire restoration efforts.

## APPENDICES

Appendix 1 – UTV Training Objectives and Assessments

Appendix 2 – UTV Conditions Decision Criteria

Appendix 3 – Class 1 UTV Approval Form



# Utility-Terrain Vehicle (UTV) Guidelines: Contractor Frequently Asked Questions

## APPENDIX

### Appendix 1 - UTV Training Objectives and Assessments

#### Training Objectives

---

***The following are the Training Objectives used to train PG&E employees toward UTV qualification; contractors will develop their own training curriculum applicable to the vehicle(s) being utilized, in accordance with the UTV manufacturer's operation and maintenance manual and recommended operating procedures:***

- Follow the appropriate policies and procedures governing the safe operation of Class 1 Utility Terrain Vehicles (UTV).
  - Determine the conditions and circumstances that warrant safe operation of a Class 1 Utility Terrain Vehicle (UTV).
  - Describe the different Class 1 Utility Terrain Vehicle (UTV) models and their uses.
  - Identify the safety hazards associated with operating a Class 1 Utility Terrain Vehicle (UTV).
  - List the PPE and safety equipment requirements for operating a Class 1 Utility Terrain Vehicle (UTV).
  - Identify the conditions which lead to Class 1 Utility Terrain Vehicle (UTV) accidents.
  - Explain the safety controls for preventing Class 1 Utility Terrain Vehicle (UTV) accidents.
- Perform Class 1 Utility Terrain Vehicle (UTV) pre-operation inspections.
  - Describe the pre-operation inspection process.
  - Identify required corrective actions to take when completing the pre-operation inspection.
  - Perform a pre-operation inspection on a Class 1 Utility Terrain Vehicle (UTV) with wheels.
  - Perform a pre-operation inspection on a Class 1 Utility Terrain Vehicle (UTV) with tracks.
- Assess terrain and operating conditions.
  - Explain the capabilities and limitations of Class 1 Utility Terrain Vehicles (UTV).
  - Explain how to drive a Class 1 Utility Terrain Vehicle (UTV) up and down hills.
  - Explain how to operate a Class 1 Utility Terrain Vehicle (UTV) in different types of terrain and conditions.
  - Describe the conditions in which tracks are appropriate.
  - Explain the differences between operating a Class 1 Utility Terrain Vehicle (UTV) with tracks and with wheels.
- Safely operate a Class 1 Utility Terrain Vehicle (UTV) equipped with wheels or tracks.
  - Wear approved PPE and follow safety rules for self and passengers.
  - Start and stop the engine according to procedures.
  - Drive the vehicle with wheels at safe speeds on all terrains.
  - Select the correct four-wheel drive settings according to terrain and conditions with wheels.
  - Avoid side-hilling when driving up hills and slopes with wheels.
  - Drive safely up and down hills with wheels.
  - Execute a contingency plan when needed.
  - Drive a Class 1 Utility Terrain Vehicle (UTV) with tracks at safe speeds on all terrains.
  - With tracks, select the correct four-wheel drive settings according to terrain and conditions.
  - Drive safely with tracks up and down hills.
- Transport cargo in a Class 1 Utility Terrain Vehicle (UTV).
  - Explain safe practices for transporting cargo.
  - Properly secure a load in the Class 1 Utility Terrain Vehicle (UTV) cargo box.
- Load and unload a Class 1 Utility Terrain Vehicle (UTV) on a trailer or utility truck.
  - Unload a Class 1 Utility Terrain Vehicle (UTV) from a trailer or utility truck.
  - Load a Class 1 Utility Terrain Vehicle (UTV) onto a trailer or utility truck.



# Utility-Terrain Vehicle (UTV) Guidelines: Contractor Frequently Asked Questions

## Training Assessment

---

*Contractors must qualify operators using a knowledge and skill assessment. The knowledge and skill assessment used to qualify operators must, at minimum, meet the requirements provided in the following Skill Assessment and Qualification:*

## Skill Assessment and Qualification

Participant Name (Print) / Employee ID:		Evaluator Name (Print):
Personnel Number / ISN Badge Number:		Evaluator Employee ID:
Training Location:	Date:	<b>Evaluator Signature:</b>
Driv.Lic. #	Driv. Lic. Expir. Date:	<b>Equipment Description (Make, Model, Vehicle Number):</b>
<b>Notes:</b>		





# Utility-Terrain Vehicle (UTV) Guidelines: Contractor Frequently Asked Questions

## Skill Assessment: Class 1 Utility Terrain Vehicle (UTV) - Wheels

### Overview

In order to successfully complete the Skill Assessment, each participant must demonstrate the ability to perform the following task:

Perform Class 1 Utility Vehicle (UTV) pre-operation inspections.

Safely operate a Class 1 Utility Terrain Vehicle (UTV) with wheels.

Transport cargo in a Class 1 Utility Terrain Vehicle (UTV) .

Load and unload a Class 1 Utility Terrain Vehicle (UTV) on a trailer or utility truck.

### Pass Criteria

Participants must pass ALL Critical Items and 16 out of 20 coachable items to pass the Class I UTV Skill Assessment.

✓ = Meets expectations    ✗ = Does not meet expectations    N/A = Not applicable

Pre-Operation Inspection	✓	✗	N/A
<b>Performs a Pre-Operation Inspection [CR].</b> Checks tire pressure and condition. Checks wheels for damage and abnormal play. Ensure lug nuts tightened. Checks coolant level. Checks lights. Checks all safety related items. Checks fuel tank and fuel level to ensure enough fuel for the trip.			
<b>Checks engine oil level. [CR]</b>			
<b>Checks brake fluid level. [CR]</b>			
<b>Checks brakes by pressing down on the brake pedal and making sure there is firm resistance and the pedal fully returns to position when released.[CR]</b>			
Checks safety related items, including: Rollover Protection Structure (ROPS) Hood latch secure Tailgate/Cargo box closed			
<b>Comments—Document any rankings of "N/A" and "Does not meet expectations."</b>			



# Utility-Terrain Vehicle (UTV) Guidelines: Contractor Frequently Asked Questions

## Skill Assessment: Class 1 Utility Terrain Vehicle (UTV) – Wheels, continued

Pre-Operation Inspection, continued	✓	✗	N/A
Checks accelerator pedal by pressing it a few times to ensure it operates freely and it returns to the rest position when released.			
Applies brake holding mechanism and checks if it operates properly.			
Checks doors or a cab net kit is installed.			
Checks seat belts for any damage. Fasten seat belts and confirm they latch securely.			
Checks if steering wheel operates freely by completely turning it from side to side.			
Locates Operator Guide.			
<b>Comments—Document any rankings of "N/A" and "Does not meet expectations."</b>			



# Utility-Terrain Vehicle (UTV) Guidelines: Contractor Frequently Asked Questions

## Skill Assessment: Class 1 Utility Terrain Vehicle (UTV) – Wheels, continued

Safety	✓	✗	N/A
<b>At all times, operator utilizes approved Personal Protective Equipment (PPE) and identifies if passengers are wearing appropriate PPE. [CR]</b>			
Ensures doors are properly latched; cab nets secure.			
Stays alert to surrounding conditions.			
Operating Skills	✓	✗	N/A
<b>Operates equipment safely and proficiently. [CR]</b>			
Starts and stops engine according to recommended procedures. Brake pedal is pressed down firmly Seat belt is latched			
Selects appropriate paths when driving. Follows instructions Identifies and chooses path of least resistance Accelerates and decelerates as needed for turning and stability control Selects appropriate drive and gear for terrain and conditions Checks for other vehicles and obstacles while traveling (look ahead)			
Selects appropriate paths when driving on hills. Avoids side hills Rides straight up hill Rides straight down hill Checks for other vehicles and obstacles while traveling (look ahead)			
Selects appropriate paths when driving over obstacles. Slows down and approaches obstacle; stops as needed Evaluates obstacle prior to driving Identifies and chooses path of least resistance			
Selects the correct four-wheel drive settings according to terrain and conditions. Vehicle with wheels			
<b>Comments—Document any rankings of "N/A" and "Does not meet expectations."</b>			



# Utility-Terrain Vehicle (UTV) Guidelines: Contractor Frequently Asked Questions

## Skill Assessment: Class 1 Utility Terrain Vehicle (UTV) – Wheels, continued

Cargo	✓	✗	N/A
Secures cargo according to recommended procedures. Ensures accessories are properly secured Identifies if cargo shifts during transport and corrects as needed			
Identifies maximum load transporting capacity.			
Adheres to recommended cargo capacities. Defender: Uses Low gear if total payload is greater than 860 lbs.			
Assures GVWR is appropriate for load.			
Trailing			
Performs pre-trip inspection of trailer.			
Load and unload equipment onto/off trailer safely.			
<b>Secure equipment to trailer following tie-down procedures. [CR]</b> Ensures equipment is secured using approved tie-down points Use DOT tie down straps			
Comments—Document any rankings of "N/A" and "Does not meet expectations."			



## Skill Assessment: Class 1 Utility Terrain Vehicle (UTV) - Tracks

### Overview

In order to successfully complete the Skill Assessment, each participant must demonstrate the ability to perform the following task:

- Perform Class 1 Utility Vehicle (UTV) pre-operation inspections.
- Safely operate a Class 1 Utility Terrain Vehicle (UTV) with tracks.
- Transport cargo in a Class 1 Utility Terrain Vehicle (UTV) .
- Load and unload a Class 1 Utility Terrain Vehicle (UTV) on a trailer or utility truck.

### Pass Criteria

Participants must pass ALL Critical Items and 16 out of 20 coachable items to pass the Class 1 UTV Skill Assessment.

✓ = Meets expectations    ✗ = Does not meet expectations    N/A = Not applicable

Pre-Operation Inspection	✓	✗	N/A
<b>Performs a Pre-Operation Inspection [CR].</b> Checks track condition. Checks tracks for damage and abnormal play. Checks coolant level. Checks lights. Checks all safety related items. Checks fuel tank and fuel level to ensure enough fuel for the trip.			
<b>Checks engine oil level. [CR]</b>			
<b>Checks brake fluid level. [CR]</b>			
<b>Checks brakes by pressing down on the brake pedal and making sure there is firm resistance and the pedal fully returns to position when released.[CR]</b>			
Checks safety related items, including: Rollover Protection Structure (ROPS) Hood latch secure Tailgate/Cargo box closed			
<b>Comments—Document any rankings of "N/A" and "Does not meet expectations."</b>			



# Utility-Terrain Vehicle (UTV) Guidelines: Contractor Frequently Asked Questions

## Skill Assessment: Class 1 Utility Terrain Vehicle (UTV) - Tracks, continued

Pre-Operation Inspection, continued	✓	✗	N/A
Checks accelerator pedal by pressing it a few times to ensure it operates freely and it returns to the rest position when released.			
Applies brake holding mechanism and checks if it operates properly.			
Checks doors or a cab net kit is installed.			
Checks seat belts for any damage. Fasten seat belts and confirm they latch securely.			
Avoids turning wheel while vehicle stopped.			
Locates Operator Guide.			
<b>Comments—Document any rankings of "N/A" and "Does not meet expectations."</b>			



# Utility-Terrain Vehicle (UTV) Guidelines: Contractor Frequently Asked Questions

## Skill Assessment: Class 1 Utility Terrain Vehicle (UTV) - Tracks, continued

Safety	✓	✗	N/A
<b>At all times, operator utilizes approved Personal Protective Equipment (PPE) and identifies if passengers are wearing appropriate PPE. [CR]</b>			
Ensures doors are properly latched; cab nets secure.			
Stays alert to surrounding conditions.			
Operating Skills	✓	✗	N/A
<b>Operates equipment safely and proficiently. [CR]</b>			
Starts and stops engine according to recommended procedures. Brake pedal is pressed down firmly Seat belt is latched			
Selects appropriate paths when driving. Follows instructions Identifies and chooses path of least resistance Accelerates and decelerates as needed for turning and stability control Selects appropriate drive and gear for terrain and conditions Checks for other vehicles and obstacles while traveling (look ahead)			
Selects appropriate paths when driving on hills. Avoids side hills Rides straight up hill Rides straight down hill Checks for other vehicles and obstacles while traveling (look ahead)			
Selects appropriate paths when driving over obstacles. Slows down and approaches obstacle; stops as needed Evaluates obstacle prior to driving Identifies and chooses path of least resistance			
Selects the correct four-wheel drive settings according to terrain and conditions. Vehicle with tracks			
Comments—Document any rankings of "N/A" and "Does not meet expectations."			



# Utility-Terrain Vehicle (UTV) Guidelines: Contractor Frequently Asked Questions

## Skill Assessment: Class 1 Utility Terrain Vehicle (UTV) - Tracks, continued

Cargo	✓	✗	N/A
Secures cargo according to recommended procedures. Ensures accessories are properly secured Identifies if cargo shifts during transport and corrects as needed			
Identifies maximum load transporting capacity.			
Adheres to recommended cargo capacities. Defender: Uses Low gear if total payload is greater than 860 lbs.			
Assures GVWR is appropriate for load.			
Trailing			
Performs pre-trip inspection of trailer.			
Load and unload equipment onto/off trailer safely.			
<b>Secure equipment to trailer following tie-down procedures. [CR]</b> Ensures equipment is secured using approved tie-down points Use DOT tie down straps			
Comments—Document any rankings of "N/A" and "Does not meet expectations."			





# Utility-Terrain Vehicle (UTV) Guidelines: Contractor Frequently Asked Questions

## Appendix 2 - UTV Conditions Decision Criteria

### Goal Oriented Decision Matrix

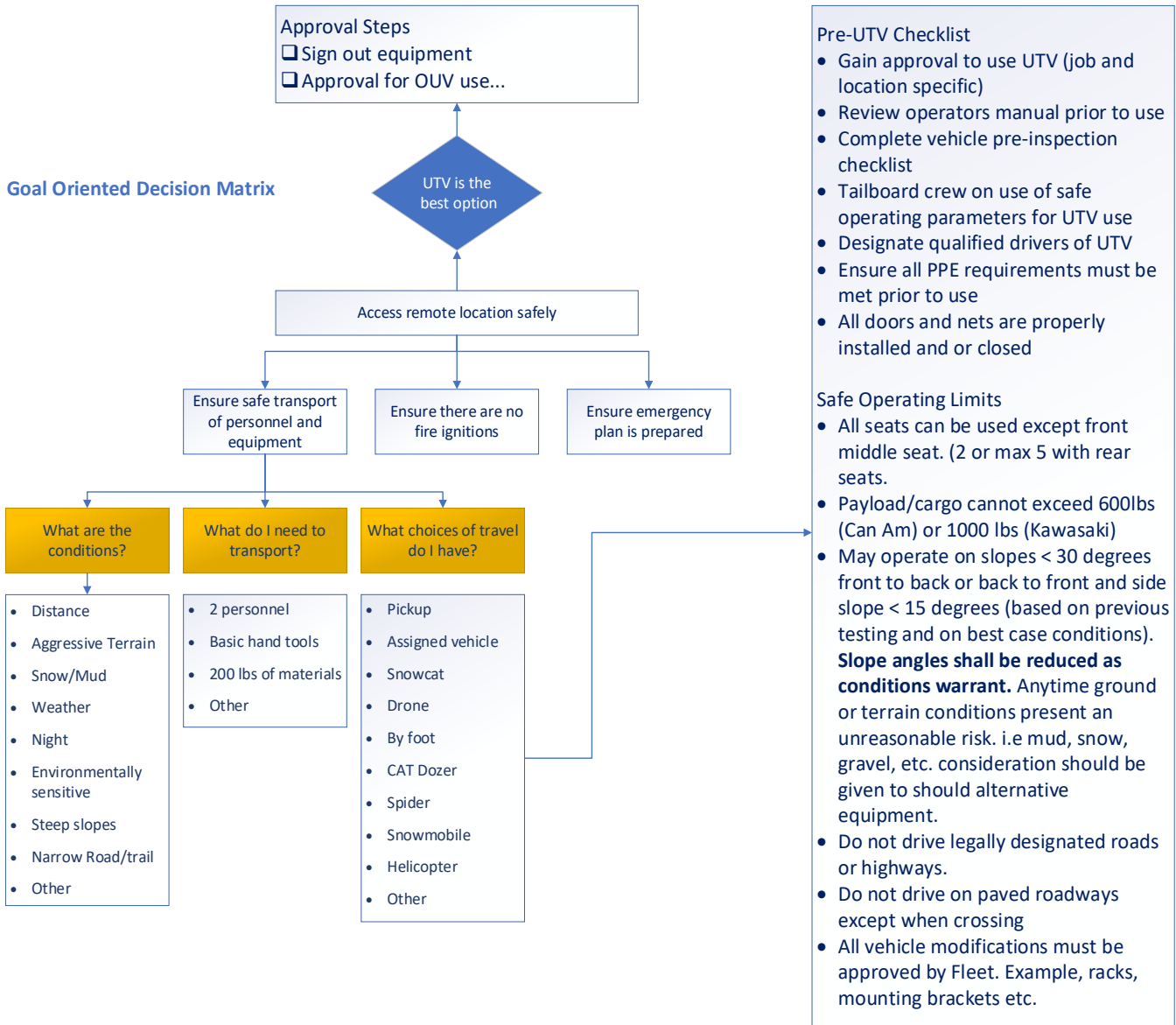



# Utility-Terrain Vehicle (UTV) Guidelines: Contractor Frequently Asked Questions

## Appendix 3 - Class 1 UTV Approval Form

### PG&E UTV APPROVAL FORM

<b>WP/Job No:</b>	<b>WP/Job Title:</b>	<b>Date:</b>
<b>Location of WP/Job No:</b>		
<b>WP/Job Scope Description:</b>		
<b>Reason for UTV:</b>		

<b>WORK PLAN REVIEW</b>	
<b>Method of Transportation</b>	<b>Reason why Can Not use</b>
<input type="checkbox"/> PG&E Pickup or SUV	
<input type="checkbox"/> Other Alternatives Snowcat, Drone, Foot, Helicopter, other	

<b>UTV to be used</b>	<b>Unit Number and Operator info</b>
<input type="checkbox"/> PG&E UTV# and Operator Corp Id(s) to be used	B _____ Op Corp ID _____ Op Corp ID _____

### Approval and Notification

Supervisor Approval: \_\_\_\_\_ / \_\_\_\_\_  
Print/Sign Date

Superintendent/Manager Approval: \_\_\_\_\_ / \_\_\_\_\_  
Print/Sign Date

## Operating Requirements for Utility-Terrain Vehicles Procedure

### SUMMARY

This utility procedure provides operating instructions for PG&E-owned and rented Off-Highway Utility Vehicles (OUV), including recreational off-highway vehicles (ROVs), utility-terrain vehicles (UTVs), golf carts and low-speed vehicles. For the purpose of this document all references and subsequent procedures, the terms ROV and UTV will be referred as Class 1 UTVs, and golf carts and low speed vehicles will be referred as Class 2 UTV to simplify the industry terminology and account for PG&E modifications to various vehicle types.

Level of Use: Informational Use

### TARGET AUDIENCE

This procedure is directed to PG&E leaders and employees who use or manage UTVs (owned or rented).

### SAFETY

This procedure assists PG&E leaders and employees in obtaining required authorizations, training prior operation, and identifying and avoiding hazards associated with UTVs.

Always follow appropriate procedures while operating class 1 UTVs. Never compromise personal and public safety. Always review and adhere to the manufacturer's recommended safety requirements before using UTVs.



#### CAUTION

Always AVOID traveling in or causing damage to environmentally sensitive areas and private property.

### BEFORE YOU START

PG&E Leaders and Operators must READ the following prerequisites:

- Utility Standard: TRAN-2053S Utility-Terrain Vehicles Standard

Operators-in-training must COMPLETE the following prerequisites:

- BECOME familiar with the manufacturer's operation and maintenance manual and recommended operating procedures.
- COMPLETE PG&E Academy training specific to Class 1 UTVs. This training includes classroom and hands-on operation with a qualified instructor. The class familiarizes students with the vehicle's capabilities and special handling characteristics.
  - Initial Training Course Codes: EQIP-0066WBT (pre-req), EQIP-0066
  - Annual Refresher Training Course Code: EQIP-0067WBT
  - Re-qualification Training Course Code (every three years): EQIP-0066Q

## Operating Requirements for Utility-Terrain Vehicles Procedure

**BEFORE YOU START** (continued)

**NOTE**

Operators who complete training are qualified to rent several brands of UTVs from different manufacturers without additional training. UTVs exceeding 30mph may not be rented.

- PRACTICE in safe areas free from obstacles and on a consistent surface of sand, dirt, snow, etc.

**TABLE OF CONTENTS**

SUBSECTION	TITLE	PAGE
1.	General Information .....	3
2.	Decision Criteria on Class 1 and Class 2 UTV Use .....	4
3.	Required UTV Enhanced Training Operator Qualifications and Requalifications .....	4
4.	Operator Safety .....	7
5.	General Operating Requirements .....	8
6.	Pre-operation Inspection .....	9
7.	Operating UTVs .....	10
8.	Maintenance Criteria are to Match Manufacturer Recommendations .....	12
Appendix	.....	16

## Operating Requirements for Utility-Terrain Vehicles Procedure





### PROCEDURE STEPS

#### 1 General Information

1.1 All PG&E-purchased Class 1 UTV units must be governed to less than 30 mph and must prevent the vehicle from exceeding 15 mph if the driver’s seatbelt is not fastened, brightly colored three-point seat belt assemblies, cab doors or nets, eliminate the use of the front middle seat, and a rollover protection structure (ROPS) as shown in figure 1 below. PG&E has approved the Class 1 UTV models listed below for purchase:

- Can-Am Maverick Trail 800 DPS
- Can-Am Defender XTP HD10 DPS
- Can-Am Defender HD10 Max XT DPS
- Kawasaki Mule Pro DX EPS

**Figure 1 – Class 1 UTV Units**





	Picture	Make/Model	People	Industry Current Classification	PG&E Classification	Top Speed	Speed limiting	TD-2412P-01 PPE	Seatbelts	Driver Seatbelt Interlock	ROPS	Doors/ Cab Nets
Units to be retrofitted with speed governors (“Keys”) at 25mph		Can-Am Defender Max XT HD10	4-person	RDV	Class 1	55 MPH	30 or less	DOT Helmet Goggles	Yes	Yes	Yes	Doors
		Can-Am Defender XT-P HD10	2-person	RDV	Class 1	55 MPH	30 or less	DOT Helmet Goggles	Yes	Yes	Yes	Doors
		Can-Am Maverick Trail	2-person	RDV	Class 1	55 MPH	30 or less	DOT Helmet Goggles	Yes	Yes	Yes	Doors
		Kawasaki Pro DX EPS	2-person	UTV	Class 1	29 MPH	N/A	DOT Helmet Goggles	Yes	No	Yes	Doors

1.2 Class 1 UTV units that do not meet the specification listed in section 1.1 may not be rented. UTVs are available for rental through Rental Central. Transportation services personnel have also approved various Class 2 UTVs for purchase. Approvals are based on a variety of factors, including minimum safety requirements that provide necessary protection to all employees.

1.3 Class 2 UTV units are designed for operation off the highway and have a maximum speed of 25 mph. UTVs, such as the Cushman 800 Electric, are capable of transporting employees and light-weight materials within paved or off-road PG&E facilities.

## Operating Requirements for Utility-Terrain Vehicles Procedure

**Figure 2 – Class 2 UTV Units**

Picture	Make/Model	People	Industry Current Classification	PG&E Classification	Top Speed	Speed limiting	TD-2412P-01 PPE	Seatbelts	Driver Seatbelt Interlock	ROPS	Doors/ Cab Nets
	Cushman 800	2-person	UTV	Class 2	15 MPH	N/A	Hard Hat Eye protection	No	No	No	No
	E-Z-GO Terrain 250	2-person	UTV	Class 2	17 MPH	N/A	Hard Hat Eye protection	No	No	No	No
	John Deere Gator	2-person	UTV	Class 2	15 MPH	N/A	Hard Hat Eye protection	No	No	No	No
	Polaris Gem E4	4-person	UTV	Class 2	25 MPH	N/A	Hard Hat Eye protection	Yes	No	No	No

### 2 Decision Criteria on Class 1 and Class 2 UTV Use

- 2.1 Senior Vice President approval required, each Line of Business (LOB) to review based upon risk, and necessity to utilize is required of each LOB for all UTV use.
- 2.2 Use of a pickup or sport utility vehicle (SUV) shall be first priority use unless terrain and conditions warrant the use of a Class 1 UTV (Use of a Class 1 UTV is the exception, not the norm). See appendix 2 – UTV Conditions Decision Criteria.
  1. Class 1 UTV usage permitted if conditions change (aggressive terrain, slope, weather, narrow or unmaintained access roads, environmentally sensitive areas, etc.) and
  2. There are no other alternatives (Snowcat, Drone, Foot, Helicopter, other), then
  3. **Written** Manager/Superintendent or designee approval using Class 1 Pre-UTV Checklist and Safe Operating Limits criteria are required before use. See appendix 4: [Class 1 UTV Approval Form](#)
    - A. Class 1 Pre-UTV Checklist:
      - Gain approval to use a Class 1 UTV (job and location specific)
      - Review manufacturer operator’s manual prior to use
      - Complete vehicle pre-operation checklist
      - Tailboard crew on use of safe operating parameters for UTV use
      - Identify qualified UTV operators and ensure qualifications are up to date
      - Verify all operators and passengers are wearing required PPE and all doors and nets are properly installed and or closed.

## Operating Requirements for Utility-Terrain Vehicles Procedure

### B. Safe Operating Limits:

- All seats can be used except front middle seat (2 or max 5 with rear seats)
- Payload/cargo cannot exceed 600lbs unless an exception is granted (Can Am) or 1000lbs (Kawasaki)
- May operate on slopes < 30 degrees front to back or back to front and side slope < 15 degrees (based on previous testing and on best case conditions). Slope angles shall be reduced as conditions warrant. Anytime ground or terrain conditions present an unreasonable risk (e.g. mud, snow, gravel, etc.), consideration should be given to should alternative equipment
- Do not drive legally designated roads or highways
- Do not drive on paved roadways except when crossing
- All vehicle modifications (e.g. racks, mounting brackets, etc.) must be approved by Transportation Services.

4. Supervisors are required to perform annual observations of employees operating class 1 UTV's. The observations are to be entered into SafetyNet (SAFE-1025S [Safety Observation Standard](#)).

### 3 Required UTV Enhanced Training Operator Qualifications and Requalification

#### 3.1 UTV operators of Class 1 units:

1. Initial training for new Class 1 operators
2. Existing Class 1 operators will re-train and re-qualify
3. 3-year qualification and requalification cycle for Class 1 operators.

#### 3.2 UTV operators of Class 2 (golf cart version, 15 to 25 mph) units:

1. One-time initial training (one-and-done) for new Class 2 operators
2. Existing Class 2 operators do not need to be retrained.



## Operating Requirements for Utility-Terrain Vehicles Procedure

**Figure 3 – Class 1 UTV Operator Training Requirements**

	Old Training (EQJP-0066)	New Training
Validity Type	One and Done	Initial training and requalification cycle; Previous qualifications are voided Employees are required to re-train and re-qualify
Training Length	<b>1 day</b> Instructor-Led with hands-on No Requalification	<b>Initial</b> training (WBT + 2 days hands-on) is one and done <b>Refresher</b> training (WBT w/ test out option) is annual <b>Requalification</b> every third year, employees are required to re-qualify (WBT w/ test out option and one day hands-on)
Assessment	Written Assessment	<b>Initial:</b> Knowledge check in WBT and Skill Assessment/Qualification <b>Requalification:</b> Knowledge check/test out in WBT and Skill Assessment/Qualification
Content Overview	<b>ILT &amp; Practice</b> Safety/Safe Driving/Reading Terrain Pre-Inspection Operation – Hills Cargo Using the Winch Trailing – De-Trailing  Maneuvers Pre-operation inspection Demo and trailing Demo and hills	<b>WBT</b> <b>Safety and Accountability</b> – Safety message from EO Leader, Key learnings from recent incidents, determining if OUV is right for the job <b>Pre-operation inspection</b> - Including new comprehensive checklist and interactive walkthrough Operating - Hills - Maximum incline, how to determine More emphasis on side hilling (avoid, choose another path) Operating an ROV with tracks <b>ILT &amp; Practice</b> – Situational Awareness discussed throughout Hills Slope: using an indicator - Slope: how to gauge by picking a line Additional skill practice regarding maneuvers, both wheels and tracks to Operating at safe speeds, Stopping, Turning, Driving uphill and downhill Gauge slope and back down hill – Tracks -Practice maneuvers
Remediation	Repeat Qualification checklist	If participant fails Skill Assessment/Qualification (Qual or Re-Qual), need to return and take initial training. (Qual revoked)







## Operating Requirements for Utility-Terrain Vehicles Procedure

### 4 Operator Safety

4.1 WEAR required clothing AND personal protective equipment (PPE) suitable for the work and location.

- Minimum PPE requirements for Class 1 UTVs include a Department of Transportation (DOT) helmet for UTVs and eye protection (goggles or eye visor attached to the helmet).
- Minimum PPE requirements for Class 2 low-speed vehicles include a hard hat and eye protection (safety glasses).
- Other PPE items stated in the operator's manual of each specific vehicle are also required.

**Figure 4 – Ordering Information for DOT-Approved Helmets, Visors, and Goggles**

Full-Face Helmet	Size	PG&E Code #	SRM S&S CODE #
	Small 6-7/8" to 7"	M206675	206675
	Medium 7-1/8" to 7-1/4"	M206676	206676
	Large 7-3/8" to 7-1/2"	M206677	206677
	X-Large 7-5/8" to 7-3/4"	M204721	204721
<b>Half-Face Helmet</b> 	Small		HEL0823010904
	Medium		HEL0823010905
	Large		HEL0823010906
	X-Large		HEL0823010907
	2X-Large		HEL0823010908
<b>Half-Face Visor</b>  <small>*FACE SHIELD ONLY*</small>	Clear Sun-Shield Visor		HEL0923900000
	Smoke Sun-Shield Visor		HEL0923901500
<b>Goggle</b> 	Lift Safety ESD-6C Goggle Clear		2791194

## Operating Requirements for Utility-Terrain Vehicles Procedure

### 5 General Operating Requirements

5.1 PG&E-approved Class 1 UTVs for purchase include the Can-Am Maverick, Can-Am Defender and Kawasaki Mule.

1. Can-Am Maverick Trail 800 DPS is designed to carry two persons.



When transporting material in the cargo area or towing a trailer, REFER to the operator's manual for rated capacities.

2. Can-Am Defender

- Can-Am Defender XTP HD10 DPS (2 person)
- Can-Am Defender HD10 Max XT DPS (5 person)

3. Kawasaki Mule

- Kawasaki Mule Pro DX EPS (2 person)



When transporting material in the cargo area or towing a trailer; REFER to the operator's manual for rated capacities.

5.2 The following Class 2 UTVs are PG&E-approved for purchase:

- Taylor Dunn
- Cushman
- E-Z-GO
- Other units designed for low-speed travel (under 25 mph) on flat or level ground used to transport employees

5.3 PG&E-approved low-speed vehicles have various capacities too numerous to list.

5.4 Transportation Services engineers PROVIDE the manufacturer's specifications for PG&E-approved equipment for purchase.

## Operating Requirements for Utility-Terrain Vehicles Procedure

### 6 Pre-Operation Inspection

- 6.1 All Class 1 UTV Operators are to COMPLETE a pre-operation inspection [form](#) for PG&E-owned or rental vehicles (see appendix 6 – UTV Pre-Operation Checklist):
- Always CHECK the tires (condition and pressure), lights, horn, AND other safety-related items per the operator’s manual for each vehicle.
  - CHECK the fuel tank to make sure it contains more than enough fuel for the ride, AND CHECK for leaks.
  - CHECK the brakes, throttle, fluids, AND all hand controls for proper operation.
  - ENSURE doors are on OR a cab net kit is installed.
  - CHECK the seatbelt interlock functions.
- 6.2 HAVE a first aid/emergency response plan that documents planned routes, communication method, and emergency response specifics in place if traveling outside a fenced-in PG&E facility.
- 6.3 ENSURE the vehicle is equipped with the following items:
- Operator’s manual
  - A shovel and an ax that meet local and [California Department of Forestry and Fire Protection](#) requirements (when applicable)
  - When working in remote locations where communication devices do not function, a personal locator beacon (PLB) may be helpful but is not required. SEE [Safety Tailboard – Safety in the Field, “Working Alone in Remote Locations – Personal Locator Beacon.”](#) for additional information.
- 6.4 ENSURE that no unauthorized attachments to haul material have been added to the vehicle.
- 6.5 NEVER TRANSPORT material on a vehicle, except in a designated cargo box where the material is properly secured. The weight distribution carried on the vehicle influences how the vehicle performs. Unauthorized attachments and unsecured loads can cause rollover.
- 6.6 DO NOT OPERATE vehicles with malfunctioning parts.
- 6.7 KNOW the round-trip capability of the vehicle, and DO NOT ATTEMPT a long trip that may be beyond its capacity. CARRY extra gasoline in safety cans when necessary.
- 6.8 Except in emergency situations, SECURE permission before traveling over private property outside normal access or rights-of-way.

## Operating Requirements for Utility-Terrain Vehicles Procedure

### 7 Operating Class 1 UTVs

**IMPORTANT!**

READ and thoroughly UNDERSTAND the following instructions before operating any Class 1 UTV.

#### 7.1 General Precautions

1. NEVER OPERATE Class 1 UTVs without either the doors on or cab net kits installed.
2. NEVER OPERATE Class 1 UTVs without wearing a seatbelt.
3. NEVER OPERATE Class 1 UTVs without wearing an approved DOT helmet.
4. NEVER OPERATE Class 1 UTVs using the front middle seat.
5. NEVER OPERATE a vehicle that has un-authorized attachments NOR INSTALL attachments to transport material on vehicles without fleet engineering and manufacturer approval.
  - a. Only TRANSPORT material in the designated cargo box (not to exceed the vehicle and cargo box weight limitation) where the material is properly secured.
  - b. The weight distribution carried on the vehicle influences how the vehicle performs. Un-authorized attachments and un-secured loads can cause roll-over.
  - c. ENSURE that the vehicle is in safe operating condition before operating the vehicle.
6. USE AND OPERATE any vehicle in accordance with the manufacturer and PG&E instructions.
7. FOLLOW marked roads AND trails when possible.
8. KEEP CLEAR of barbed-wire fences, guy wires, communication cables, overhead power lines, and other similar hazards.
9. When parking, STOP the engine AND SET the parking brake.
10. REMOVE the keys from the ignition when the vehicle is unattended.

#### 7.2 Driving Precautions

1. Once under way, always KEEP both feet inside the vehicle.
2. ACCELERATE the engine gradually to ensure the clutch engages smoothly, if applicable.

## Operating Requirements for Utility-Terrain Vehicles Procedure

3. To turn, STEER in the direction of the turn.
4. DO NOT USE excessive speed at any time.
5. ALLOW at least 50 feet of separation when following another vehicle.
6. DRIVE defensively AND BE PREPARED for sudden stops. NEVER DRIVE FASTER than vision or conditions permit.
7. NEVER USE a railroad right-of-way for travel.
  - a. IF crossing railroad tracks is necessary, THEN SHUT OFF the vehicle before crossing AND LISTEN for an approaching train.
  - b. CROSS at a 90° angle.
8. COME to a complete stop before crossing any street or highway.
9. CROSS obstacles at 90° angles, if possible.

### 7.3 Terrain and Weather Conditions

1. NEVER CROSS deep or swiftly moving water. The natural buoyancy of tires can cause a loss of directional control.
2. NEVER CROSS frozen lakes or rivers. REMEMBER that lakes appear as meadows when covered with snow and ice.
3. REDUCE speed AND USE caution when driving on wet roads, paved roads, or loose gravel. LIMIT this type of driving to short distances whenever possible.
4. CROSS metal surfaces such as bridge gates, railroad tracks, and expansion joints with extreme caution to avoid skidding.
5. Skids sometimes occur when driving on ice and in snow or mud.
  - a. HANDLE skidding safely by steering in the direction of the skid.
  - b. DO NOT APPLY the brakes OR CHANGE the throttle position until directional control is regained.
6. EXERCISE caution when driving UTVs up steep hills, down hills, sideways on steep hill grades, and when making sudden stops. UTVs must never exceed their operating limitations, as instructed by PG&E Academy personnel.

## Operating Requirements for Utility-Terrain Vehicles Procedure

### **8 Maintenance Criteria are to Match Manufacturer Recommendations**

- 8.1 FOLLOW the manufacturer's recommendations for lubricating and servicing vehicles.
- 8.2 Transportation Services personnel PERFORM or AUTHORIZE service and repair of purchased vehicles.
- 8.3 Report and deficiencies to the local garage or field mechanic immediately
- 8.4 Rental vehicles are serviced and managed by their rental contract agreement.
- 8.5 COMPLETE the following maintenance checks before using the vehicle:
  - ENSURE that the front AND rear brakes are properly adjusted.
  - CHECK the fuel tank for leaks.
  - CHECK the engine oil level (ADD oil when needed) and water level (ADD water when needed).
  - ENSURE that the air filter is clean.
  - ENSURE that all other manufacturer-suggested check points are within specifications before each use.

**END of Instructions**

## Operating Requirements for Utility-Terrain Vehicles Procedure

### DEFINITIONS

**Class 1:** PG&E definition to group similar units by manufacturer specifications and PPE requirements, can be a ROV or UTV.

**Class 2:** PG&E definition to group similar units by manufacturers specifications typically lower speeds and PPE requirements, typically a golf cart or low-speed vehicle. To include electric cart, or gas cart with a maximum speed of 25 mph.

**Golf Cart:** A motor vehicle having an unladen weight less than 1,300 pounds, which is designed to be and is operated at not more than 17 miles per hour and designed to carry not more than two persons, including the driver.

**Low-speed vehicle:** An electric cart with a top speed more than 20 mph and less than 25 mph with a gross vehicle weight rating less than 3,000 pounds. Also known as a "neighborhood electric vehicle."

**Off-Highway Utility Vehicle (OUV):** A low or high-speed motor vehicle designed by the manufacturer for operation off the highway.

**Recreational off-highway vehicle (ROV):** A motor vehicle designed by the manufacturer for operation primarily off the highway, including the Can-Am Maverick and Can-Am Defender. Has a steering wheel for steering control and non-straddle seating for the operator and passengers. Maximum speed capability is greater than 30 mph.

**Utility-terrain vehicle (UTV):** A motor vehicle designed by the manufacturer for operation off the highway, including the Kawasaki Mule Pro-DX Diesel. Has a steering wheel for steering control and non-straddle seating provided for the operator and all passengers.

### IMPLEMENTATION RESPONSIBILITIES

The superintendents and managers in charge of personnel that operate or manage ROVs and UTVs must communicate this procedure to all affected employees.

### GOVERNING DOCUMENT

NA

### COMPLIANCE REQUIREMENT / REGULATORY COMMITMENT

NA

## Operating Requirements for Utility-Terrain Vehicles Procedure

### REFERENCE DOCUMENTS

#### Developmental References:

[California Department of Motor Vehicles \(DMV\) – Frequently Asked Questions \(FAQs\) for Recreational Off-Highway Vehicles \(ROVs\)](#)

#### Code of Safe Practices:

- [Section 1, Rule 6, “Noise Control”](#)
- [Section 3, Rule 324, “Operation of Off-Road Vehicles \(ROVs & UTVs\)”](#)

TD-2355M [Electric Maintenance and Construction Manual](#)

#### Supplemental References:

[California Department of Forestry and Fire Protection](#)

[Safety and Health Tailboard – Safety in the Field, “Working Alone in Remote Locations – Personal Locator Beacon \(PLB\)”](#)

SAFE-1025S [Safety Observation Standard](#)

### APPENDICES

Appendix 1 – UTV Classifications

Appendix 2 – UTV Conditions Decision Criteria

Appendix 3 – UTV Slope Angle Decision Point

Appendix 4 – [Class 1 UTV Approval Form](#)

Appendix 5 – Class 1 UTV Operator Training Requirements

Appendix 6 – [Class 1 UTV Pre-Operation Checklist](#)

### ATTACHMENTS

NA

### DOCUMENT REVISION

This utility procedure cancels and supersedes Utility Procedure TD-2412P-01, “Operating Requirements for Recreational Off-Highway Vehicles and Utility-Terrain Vehicles” Rev. 3, dated 10/09/2019.



**Operating Requirements for Utility-Terrain Vehicles Procedure**

**DOCUMENT APPROVER**

Chris Piacentini, Director, Transportation Safety

**DOCUMENT OWNER**

Chris Piacentini, Director, Transportation Safety  
 Jim Powell, Senior Manager, Transportation Safety

**DOCUMENT CONTACT**

Walter Posey, Director, Electric Operations Safety  
 Ron Richardson, Sr. Director, Transmission Substation M&C  
 John Gilginas, Manager, Safety-Gas  
 Dan Amour, Sr. Manager, Casual Evaluation/Support  
 Frank Labelle, Manager, Safety  
 Brian Voyles, Manager, Fleet Engineering & Customer Strategy  
 Linda Floyd, Director, Electric Operations & Wildfire Training  
 Chris Pickett, Senior Director, PG&E Academy

**REVISION NOTES**

Where?	What Changed?
N/A	This is a new procedure

# Operating Requirements for Utility-Terrain Vehicles Procedure

## APPENDIX

### Appendix 1 – UTV Classifications

Units to be retrofitted with speed governors ("Keys") at 25mph

Kawasaki PPC changed to DOT helmet and goggles to align Class 1

Picture	Make/Model	People	Industry Current Classification	PG&E Classification	Top Speed	Speed Limiting	EN 12419:01 PPE	Seatbelts	Driver Seatbelt Interlock	ROPS	Doors/Cab Nets
	Can-Am Defender Max XT HD9	4-person	ROV	Class 1	55MPH	30 or less	DOT Helmet Goggles	Yes	Yes	Yes	Doors
	Can-Am Defender XT HD9	2-person	ROV	Class 1	55MPH	30 or less	DOT Helmet Goggles	Yes	Yes	Yes	Doors
	Can-Am Maverick Trail	2-person	ROV	Class 1	55MPH	30 or less	DOT Helmet Goggles	Yes	Yes	Yes	Doors
	Kawasaki Pro XC 1000	2-person	UTV	Class 1	29MPH	N/A	DOT Helmet Goggles	Yes	No	Yes	Doors
	Cub Cadet 800	2-person	UTV	Class 2	15MPH	N/A	Hard Hat Eye protection	No	No	No	No
	E-Z-GO Tensor 250	2-person	UTV	Class 2	17MPH	N/A	Hard Hat Eye protection	No	No	No	No
	John Deere Gator	2-person	UTV	Class 2	15MPH	N/A	Hard Hat Eye protection	No	No	No	No
	Polaris Legend 4	4-person	UTV	Class 2	25MPH	N/A	Hard Hat Eye protection	Yes	No	No	No

# Operating Requirements for Utility-Terrain Vehicles Procedure

## Appendix 2 – UTV Conditions Decision Criteria

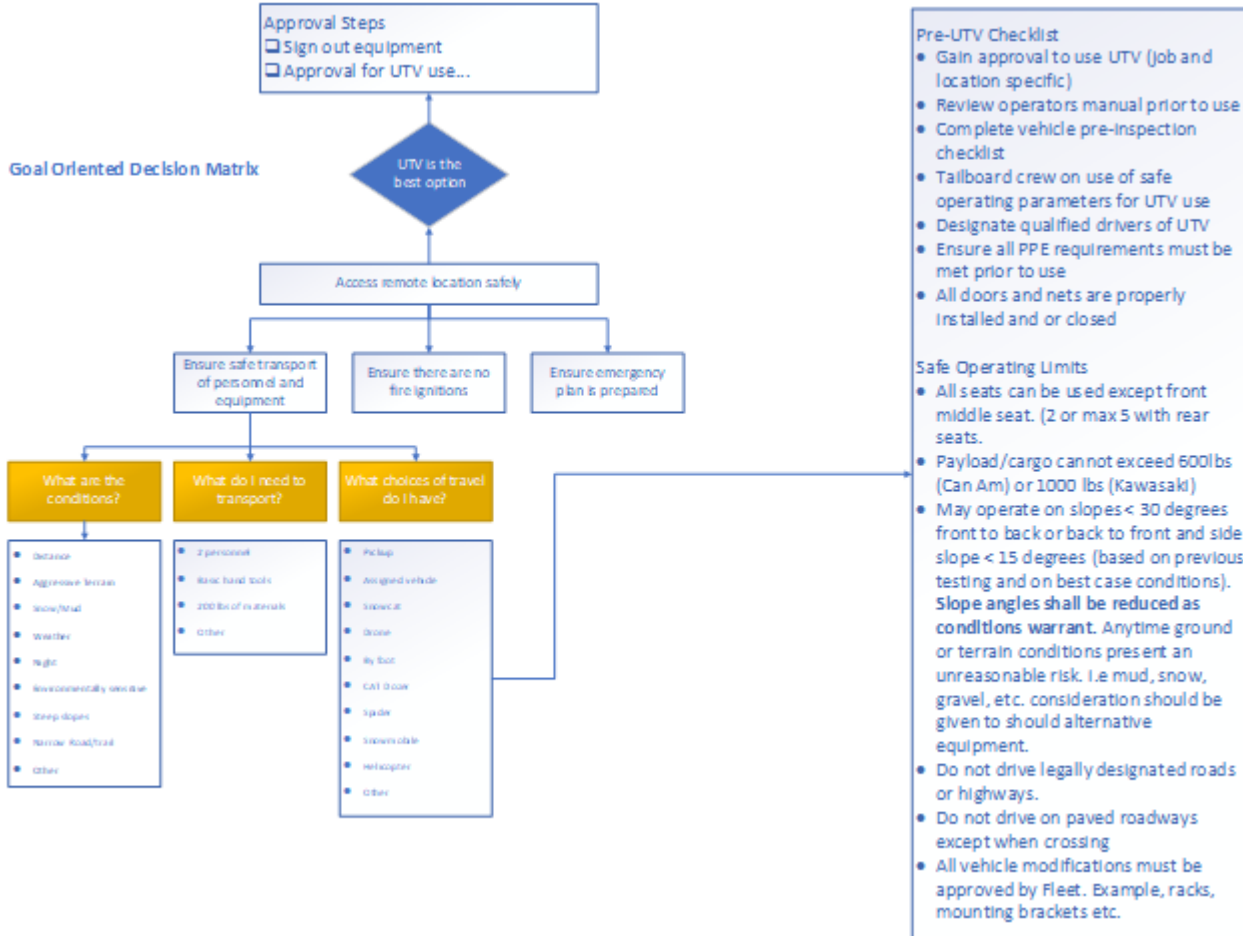

## Appendix 3 – UTV Slope Angle Decision Point

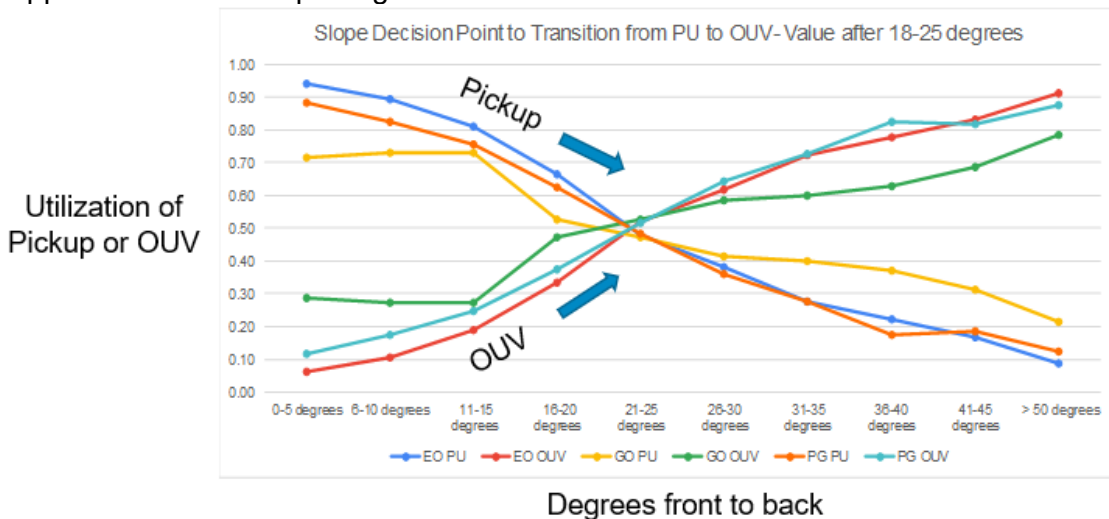

## Operating Requirements for Utility-Terrain Vehicles Procedure

 Appendix 4 – [Class 1 UTV Approval Form](#)

PG&E UTV APPROVAL FORM		
WP/Job No:	WP/Job Title:	Date:
Location of WP/Job No:		
WP/Job Scope Description:		
Reason for UTV:		
WORK PLAN REVIEW		
Method of Transportation	Reason why Can Not use	
<input type="checkbox"/> PG&E Pickup or SUV		
<input type="checkbox"/> Other Alternatives Snowcat, Drone, Foot, Helicopter, other		
UTV to be used	Unit Number and Operator info	
<input type="checkbox"/> PG&E UTV # and Operator Corp Id(s) to be used	B _____ Op Corp ID _____ Op Corp ID _____	
<u>Approval and Notification</u>		
Supervisor Approval:	/	
	Print/Sign	Date
Superintendent/Manager Approval:	/	
	Print/Sign	Date

## Operating Requirements for Utility-Terrain Vehicles Procedure

### Appendix 5 – Class 1 UTV Operator Training Requirements

	Old Training (EQIP-0066)	New Training
Validity Type	One and Done	Initial training and requalification cycle; Previous qualifications are voided Employees are required to re-train and re-qualify
Training Length	1 day Instructor-Led with hands-on No Requalification	Initial training (WBT + 2 days hands-on) is one and done Refresher training (WBT w/ test out option) is annual Requalification every third year, employees are required to re-qualify (WBT w/ test out option and one day hands-on)
Assessment	Written Assessment	Initial: Knowledge check in WBT and Skill Assessment/Qualification Requalification: Knowledge check/test out in WBT and Skill Assessment/Qualification
Content Overview	<b>ILT &amp; Practice</b> Safety/Safe Driving/Reading Terrain Pre-Inspection Operation – Hills Cargo Using the Winch Trailing – De-Trailing  Maneuvers Pre-operation inspection Demo and trailing Demo and hills	<b>WBT</b> <b>Safety and Accountability</b> – Safety message from EO Leader, Key learnings from recent incidents, determining if OUV is right for the job <b>Pre-operation inspection</b> - Including new comprehensive checklist and interactive walkthrough Operating - Hills - Maximum incline, how to determine More emphasis on side hilling (avoid, choose another path) Operating an ROV with tracks <b>ILT &amp; Practice</b> – Situational Awareness discussed throughout Hills Slope: using an indicator - Slope: how to gauge by picking a line Additional skill practice regarding maneuvers, both wheels and tracks to Operating at safe speeds, Stopping, Turning, Driving uphill and downhill Gauge slope and back down hill – Tracks -Practice maneuvers
Remediation	Repeat Qualification checklist	If participant fails Skill Assessment/Qualification (Qual or Re-Qual), need to return and take initial training. (Qual revoked)

## Operating Requirements for Utility-Terrain Vehicles Procedure

Appendix 6 – [Class 1 UTV Pre-Operation Checklist](#)

### Can -Am Units:

Before using this vehicle, the operator should always perform the following pre-ride inspection check list.

### Pre-Ride Inspection Check List

#### What to Do Before Starting the Engine (Key OFF)

ITEMS TO BE INSPECTED	INSPECTION TO PERFORM	✓
Tires	Check tire pressure and condition. Refer to <i>SPECIFICATIONS</i> and adjust according to load.	
Wheels	Check wheels for damage and for abnormal play, Make sure that lug nuts are tightened. Refer to <i>WHEELS AND TIRES</i> in <i>MAINTENANCE PROCEDURES</i> for torque specification.	
Radiator	Check cleanliness of the radiator.	
Front grill kit	Inspect front grill kit for cleanliness.	
Engine oil	Check engine oil level.	
Coolant	Check coolant level.	
Brake fluid	Check brake fluid level.	
Engine air filter	Inspect the engine air filter, clean or replace if needed (service more often when riding in dusty conditions).	
CVT air filter	Inspect and clean the CVT air filter (when riding in dusty conditions).	
Drive shaft boots	Check drive shaft boots and protectors condition.	



## Operating Requirements for Utility-Terrain Vehicles Procedure

ITEMS TO BE INSPECTED	INSPECTION TO PERFORM	✓
Cargo and load	<p><b>Cargo Load:</b> If you transport a cargo, respect the maximum loading capacity. Refer to <i>SPECIFICATIONS</i></p> <p><b>Vehicle Load:</b> Ensure that total load on the vehicle (including operator, passengers, cargo, tongue weight and added accessories) does not exceed the specifications. Refer to <i>CARRYING LOADS</i>.</p>	
	<p>If you are pulling a trailer or another equipment:</p> <ul style="list-style-type: none"> <li>– Check hitch and trailer ball condition.</li> <li>– Respect the tongue capacity and towing capacity as indicated on the label affixed to the hitch or refer to <i>SPECIFICATIONS</i>.</li> <li>– Ensure trailer is properly secured to hitch.</li> </ul>	
Rear cargo box	Check if the cargo box is properly latched.	
	Check if tail gate is properly latched.	
Chassis and suspension	Check underneath vehicle for any debris on chassis or suspension and clean them properly.	
Brake Holding Mechanism (If equipped)	Apply brake holding mechanism and check if it operates properly.	
Heater air filters (if equipped)	Inspect heater air filters, clean if needed (service more often when riding in dusty conditions).	

**Operating Requirements for Utility-Terrain Vehicles Procedure**

**What to Do Before Starting the Engine (Key ON)**

ITEMS TO BE INSPECTED	INSPECTION TO PERFORM	✓
Gauge	Check operation of indicator lamps in gauge (With the D.E.S.S. key ON, briefly push the Start/ Stop button).	
	Check for messages in gauge.	
Lights	Check operation and cleanliness of headlights and taillight.	
	Check operation of high and low beam.	
	Check operation of brake light.	
Seats, doors and seat belts	Check seat adjustment and make sure locking device is properly engaged before riding.	
	Check doors for any damage. Have the doors replaced if any damage is found. Close both doors and confirm that they latch securely.	
	Check seat belts for any damage (including retractors, buckles and semi-cinching tabs). Fasten seat belts and ensure that they remain securely fastened and tightened against the body	

ITEMS TO BE INSPECTED	INSPECTION TO PERFORM	✓
Accelerator pedal	Press on the accelerator pedal a few times to ensure it operates freely and it returns to the rest position when released.	
Brake pedal	Press down on the brake pedal and make sure you feel firm resistance and that it fully returns to position when released.	
Fuel level	Check the fuel level.	



## Operating Requirements for Utility-Terrain Vehicles Procedure

### What to Do After the Engine is Started

ITEMS TO BE INSPECTED	INSPECTION TO PERFORM	✓
Steering	Check if steering operates freely by completely turning it from side to side.	
Ignition switch	Turn the ignition switch to OFF to verify if engine will shut down. Restart engine.	
Shift lever	Check operation of shift lever (P, R, N, H and L).	
2WD/4WD selector	Check operation of 2WD/4WD selector.	
Brakes	Drive forward slowly a few feet and apply brakes. The brake pedal must feel firm when applied. The pedal must return to rest position when released. The brakes must respond adequately to the driver's input.	
Winch (if equipped)	Check operation of winch.	

### Kawasaki Units:

## HOW TO OPERATE

#### Daily Checks

Check the following items each day before operation. The time required is minimal, and habitual performance of these checks will help ensure safe, reliable operation.  
 If any irregularities are found during these checks, refer to the "MAINTENANCE AND ADJUSTMENT" chapter, see your dealer, or refer to the Service Manual for the action required to return the vehicle to a safe operating condition.

**⚠ WARNING**

Failure to perform these checks before operation may result in serious damage or an accident. Always perform daily checks before operation.

**⚠ DANGER**

Exhaust gas contains carbon monoxide, a colorless, odorless poisonous gas. Inhaling carbon monoxide can cause serious brain injury or death. DO NOT run the engine in enclosed areas. Operate only in a well-ventilated area.

- |                       |   |
|-----------------------|---|
| Fuel .....            | Enough fuel in tank, no leaks.  |
| Fuel Filter .....     | Check filter element for contamination.   |
| Water Separator ..... | Check for water accumulation and filter element contamination.                        |
| Engine Oil .....      | Oil level between Full and Low holes on the dipstick (when engine is cold), no leaks. |

# Operating Requirements for Utility-Terrain Vehicles Procedure

Tires .....	<p>Air pressure (when cold):</p> <table border="1" style="width: 100%; border-collapse: collapse; text-align: center;"> <thead> <tr> <th style="width: 15%;">Tire</th> <th style="width: 35%;">Load</th> <th style="width: 50%;">Cold Tire Pressure</th> </tr> </thead> <tbody> <tr> <td rowspan="2">Front</td> <td>Up to 717 kg (1 581 lb)</td> <td>78.4 kPa (0.80 kgf/cm<sup>2</sup>, 11.4 psi)</td> </tr> <tr> <td>Up to 590 kg (1 300 lb)</td> <td>110 kPa (1.12 kgf/cm<sup>2</sup>, 16.0 psi)</td> </tr> <tr> <td>Rear</td> <td>590 ~ 717 kg (1 300 ~ 1 581 lb)</td> <td>130 kPa (1.33 kgf/cm<sup>2</sup>, 18.9 psi)</td> </tr> </tbody> </table> <p>Check for cuts, cracks, damage, or excessive wear. Check for any imbedded stones or other foreign particles in tread.</p>	Tire	Load	Cold Tire Pressure	Front	Up to 717 kg (1 581 lb)	78.4 kPa (0.80 kgf/cm <sup>2</sup> , 11.4 psi)	Up to 590 kg (1 300 lb)	110 kPa (1.12 kgf/cm <sup>2</sup> , 16.0 psi)	Rear	590 ~ 717 kg (1 300 ~ 1 581 lb)	130 kPa (1.33 kgf/cm <sup>2</sup> , 18.9 psi)
Tire	Load	Cold Tire Pressure										
Front	Up to 717 kg (1 581 lb)	78.4 kPa (0.80 kgf/cm <sup>2</sup> , 11.4 psi)										
	Up to 590 kg (1 300 lb)	110 kPa (1.12 kgf/cm <sup>2</sup> , 16.0 psi)										
Rear	590 ~ 717 kg (1 300 ~ 1 581 lb)	130 kPa (1.33 kgf/cm <sup>2</sup> , 18.9 psi)										
Front Final Gear Case Oil .....	Oil level come to the bottom of the filler opening, no leaks.											
Transmission Case Oil .....	Oil level between high and low levels on the rib in the oil filler opening, no leaks.											
Coolant .....	Coolant level between level lines (when engine is cold), no leaks.											
Air Cleaner Element .....	Check for dirt; clean or replace as required.											
Screen at Belt Drive Transmission (CVT) Air Duct .....	Check and clean the screen for obstruction by insects, mud or foreign object.											
Throttle .....	Throttle pedal free play 2 ~ 10 mm (0.08 ~ 0.39 in.). Throttle pedal operates smoothly and returns to rest position when released.											
Steering .....	Steering wheel free play 0 ~ 20 mm (0 ~ 0.79 in.). Action smooth without excessive play, rough spots, or strange noises.											
Brakes .....	Check for braking effectiveness (while test running). Brake pedal free play 2 ~ 10 mm (0.08 ~ 0.39 in.). Brake fluid level between level lines, no leaks. Parking brake: Stops vehicle completely. Visually check the return springs for damage.											
Parking Brake Indicator .....	Make sure the parking brake indicator light illuminates when the parking brake is applied with the main switch in the "ON" position.											
Electrical Equipment .....	All lights work. Check for dirt on or damage to lights.											
ROPS .....	Make sure there is no damage to the structure or loose bolts.											
Seat Belts .....	Make sure that all seat belts are in good condition and operate properly. The belt should pull smoothly and retract when released. The latch plate should click securely with the buckle and release when the release button is pushed firmly.											
Doors .....	Make sure there is no damage to the structure or loose bolts and all doors are latched securely they are closed.											

## Operating Requirements for Utility-Terrain Vehicles Procedure

### Appendix 5 – Class 1 UTV Operator Training Requirements

	Old Training (EQIP-0066)	New Training
Validity Type	One and Done	Initial training and requalification cycle; Previous qualifications are voided Employees are required to re-train and re-qualify
Training Length	1 day Instructor-Led with hands-on No Requalification	Initial training (WBT + 2 days hands-on) is one and done Refresher training (WBT w/ test out option) is annual Requalification every third year, employees are required to re-qualify (WBT w/ test out option and one day hands-on)
Assessment	Written Assessment	Initial: Knowledge check in WBT and Skill Assessment/Qualification Requalification: Knowledge check/test out in WBT and Skill Assessment/Qualification
Content Overview	<b>ILT &amp; Practice</b> Safety/Safe Driving/Reading Terrain Pre-Inspection Operation – Hills Cargo Using the Winch Trailing – De-Trailing  Maneuvers Pre-operation inspection Demo and trailing Demo and hills	<b>WBT</b> <b>Safety and Accountability</b> – Safety message from EO Leader, Key learnings from recent incidents, determining if OUV is right for the job <b>Pre-operation inspection</b> - Including new comprehensive checklist and interactive walkthrough Operating - Hills - Maximum incline, how to determine More emphasis on side hilling (avoid, choose another path) Operating an ROV with tracks <b>ILT &amp; Practice</b> – Situational Awareness discussed throughout Hills Slope: using an indicator - Slope: how to gauge by picking a line Additional skill practice regarding maneuvers, both wheels and tracks to Operating at safe speeds, Stopping, Turning, Driving uphill and downhill Gauge slope and back down hill – Tracks -Practice maneuvers
Remediation	Repeat Qualification checklist	If participant fails Skill Assessment/Qualification (Qual or Re-Qual), need to return and take initial training. (Qual revoked)

## **APPENDIX R**

### **NIOSH Chemical Hazard Sheets**

(/niosh/index.htm)

## 2,3,7,8-Tetrachloro-dibenzo-p-dioxin

### Synonyms & Trade Names

Dioxin, Dioxine, TCDBD, TCDD, 2,3,7,8-TCDD [Note: Formed during past production of 2,4,5-trichlorophenol, 2,4,5-T & 2(2,4,5-trichlorophenoxy)propionic acid.]

### CAS No.

1746-01-6

### RTECS No.

HP3500000

### DOT ID & Guide

### Formula

$C_{12}H_4Cl_4O_2$

### Conversion

### IDLH

Ca [N.D.]

See: IDLH INDEX

**Exposure Limits****NIOSH REL**

Ca See Appendix A ([nengapdxa.html](#))

**OSHA PEL**

none

**Measurement Methods**

None available

See: NMAM or OSHA Methods

**Physical Description**

Colorless to white, crystalline solid. [Note: Exposure may occur through contact at previously contaminated worksites.]

**Molecular Weight**

322.0

**Boiling Point**

Decomposes

**Melting Point**

581°F

**Solubility**

0.00000002%

**Vapor Pressure**

(77°F): 0.000002 mmHg

**Ionization Potential**

?

**Specific Gravity**

?

**Flash Point**

?

**Upper Explosive Limit**

?

**Lower Explosive Limit**

?

### **Incompatibilities & Reactivities**

UV light (decomposes)

### **Exposure Routes**

inhalation, skin absorption, ingestion, skin and/or eye contact

### **Symptoms**

irritation eyes; allergic dermatitis, chloracne; porphyria; gastrointestinal disturbance; possible reproductive, teratogenic effects; In Animals: liver, kidney damage; hemorrhage; [potential occupational carcinogen]

### **Target Organs**

Eyes, skin, liver, kidneys, reproductive system

### **Cancer Site**

[in animals: tumors at many sites]

### **Personal Protection/Sanitation**

(See protection codes (protect.html))

**Skin:**Prevent skin contact

**Eyes:**Prevent eye contact

**Wash skin:**When contaminated/Daily

**Remove:**When wet or contaminated

**Change:**Daily

**Provide:**Eyewash, Quick drench

### **First Aid**

(See procedures (firstaid.html))

**Eye:**Irrigate immediately

**Skin:**Soap flush immediately

**Breathing:**Respiratory support

**Swallow:**Medical attention immediately

### **Respirator Recommendations**

#### **NIOSH**

**At concentrations above the NIOSH REL, or where there is no REL, at any detectable concentration:**

(APF = 10,000) Any self-contained breathing apparatus that has a full facepiece and is operated in a pressure-demand or other positive-pressure mode



(APF = 10,000) Any supplied-air respirator that has a full facepiece and is operated in a pressure-demand or other positive-pressure mode in combination with an auxiliary self-contained positive-pressure breathing apparatus

**Escape:**

(APF = 50) Any air-purifying, full-facepiece respirator (gas mask) with a chin-style, front- or back-mounted organic vapor canister having an N100, R100, or P100 filter.

[Click here \(pgintrod.html#nrp\)](#) for information on selection of N, R, or P filters.

Any appropriate escape-type, self-contained breathing apparatus

[Important additional information about respirator selection \(pgintrod.html#mustread\)](#).

**See also**

INTRODUCTION ICSC CARD: 1467

**Follow NIOSH**

Facebook (<http://www.facebook.com/NIOSH>)

Flickr (<http://www.flickr.com/photos/NIOSH>)

Pinterest (<http://www.pinterest.com/cdcgov/workplace-safety-and-health/>)

Twitter (<http://twitter.com/NIOSH>)

YouTube (<http://www.youtube.com/user/NIOSHSafetyVideos>)

**NIOSH Homepage**

NIOSH A-Z

Workplace Safety & Health Topics

Publications and Products

Programs

Contact NIOSH

Page last reviewed: April 11, 2016

Page last updated: April 11, 2016

Content source: National Institute for Occupational Safety and Health (NIOSH) (/niosh/) Education and Information Division

# Arsenic (inorganic compounds, as As)



## Synonyms & Trade Names

Arsenia, Arsenic metal [Note: OSHA considers "Inorganic Arsenic" to mean copper acetoarsenite and all inorganic compounds containing arsenic except ARSINE.]

### CAS No.

7440-38-2 (metal)

### RTECS No.

CG0525000 (metal)

### DOT ID & Guide

1558 152 (metal)

1562 152 (dust)

## Formula

As (metal)

## Conversion

### IDLH

Ca [5 mg/m<sup>3</sup> (as As)]

See: [7440382](#)

### Exposure Limits

#### NIOSH REL

Ca C 0.002 mg/m<sup>3</sup> [15-minute] [See Appendix A](#)

#### OSHA PEL

[1910.1018] TWA 0.010 mg/m<sup>3</sup>

### Measurement Methods

NIOSH [7300](#) , [7301](#) , [7303](#) , [7900](#)

, [9102](#) ;

#### OSHA ID105

See: [NMAM](#) or [OSHA Methods](#)

Metal: Silver-gray or tin-white, brittle, odorless solid.

**Molecular Weight**

74.9

**Boiling Point**

Sublimes

**Melting Point**

1135°F (Sublimes)

**Solubility**

Insoluble

**Vapor Pressure**

0 mmHg (approx)

**Ionization Potential**

NA

**Specific Gravity**

5.73 (metal)

**Flash Point**

NA

**Upper Explosive Limit**

NA

**Lower Explosive Limit**

NA

Metal: Noncombustible Solid in bulk form, but a slight explosion hazard in the form of dust when exposed to flame.

**Incompatibilities & Reactivities**

Strong oxidizers, bromine azide [Note: Hydrogen gas can react with inorganic arsenic to form the highly

### **Exposure Routes**

inhalation, skin absorption, skin and/or eye contact, ingestion

### **Symptoms**

Ulceration of nasal septum, dermatitis, gastrointestinal disturbances, peripheral neuropathy, resp irritation, hyperpigmentation of skin, [potential occupational carcinogen]

### **Target Organs**

Liver, kidneys, skin, lungs, lymphatic system

### **Cancer Site**

[lung & lymphatic cancer]

### **Personal Protection/Sanitation**

([See protection codes](#))

**Skin:**Prevent skin contact

**Eyes:**Prevent eye contact

**Wash skin:**When contaminated/Daily

**Remove:**When wet or contaminated

**Change:**Daily

**Provide:**Eyewash, Quick drench

### **First Aid**

([See procedures](#))

**Eye:**Irrigate immediately

**Skin:**Soap wash immediately

**Breathing:**Respiratory support

**Swallow:**Medical attention immediately

### **Respirator Recommendations**

([See Appendix E](#))

### **NIOSH**

**At concentrations above the NIOSH REL, or where there is no REL, at any detectable concentration:**

(APF = 10,000) Any self-contained breathing

apparatus that has a full facepiece and is operated in a pressure-demand or other positive-pressure mode

(APF = 10,000) Any supplied-air respirator that has a full facepiece and is operated in a pressure-demand

or other positive-pressure mode in combination with

an auxiliary self-contained positive-pressure breathing

**Escape:**

(APF = 50) Any air-purifying, full-facepiece respirator (gas mask) with a chin-style, front- or back-mounted acid gas canister having an N100, R100, or P100 filter.

[Click here](#) for information on selection of N, R, or P filters.

Any appropriate escape-type, self-contained breathing apparatus

[Important additional information about respirator selection](#)

**See also**

[INTRODUCTION](#) ICSC CARD: [0013](#) [MEDICAL TESTS: 0017](#)

(/niosh/index.htm)

## Asbestos

### Synonyms & Trade Names

Actinolite, Actinolite asbestos, Amosite (cummingtonite-grunerite), Anthophyllite, Anthophyllite asbestos, Chrysotile, Crocidolite (Riebeckite), Tremolite, Tremolite asbestos

### CAS No.

1332-21-4

### RTECS No.

CI6475000

### DOT ID & Guide

2212 171(blue, brown)

2590 171(white)

### Formula

Hydrated mineral silicates

### Conversion

### IDLH

Ca [N.D.]

See: IDLH INDEX

**Exposure Limits****NIOSH REL**

Ca See Appendix A (nengapdx.html) See Appendix C (nengapdx.html)

**OSHA PEL**

[1910.1001] [1926.1101] See Appendix C (nengapdx.html)

**Measurement Methods**

**NIOSH** 7400 , 7402 ;

**OSHA** ID160 , ID191

See: NMAM or OSHA Methods

**Physical Description**

White or greenish (chrysotile), blue (crocidolite), or gray-green (amosite) fibrous, odorless solids.

**Molecular Weight**

Varies

**Boiling Point**

Decomposes

**Melting Point**

1112°F (Decomposes)

**Solubility**

Insoluble

**Vapor Pressure**

0 mmHg (approx)

**Ionization Potential**

NA

**Specific Gravity**

?

**Flash Point**

NA

**Upper Explosive Limit**

NA

**Lower Explosive Limit**

NA



Noncombustible Solids

**Incompatibilities & Reactivities**

None reported

**Exposure Routes**

inhalation, ingestion, skin and/or eye contact

**Symptoms**

Asbestosis (chronic exposure): dyspnea (breathing difficulty), interstitial fibrosis, restricted pulmonary function, finger clubbing; irritation eyes; [potential occupational carcinogen]

**Target Organs**

respiratory system, eyes

**Cancer Site**

[lung cancer]

**Personal Protection/Sanitation**

(See protection codes (protect.html))

**Skin:**Prevent skin contact

**Eyes:**Prevent eye contact

**Wash skin:**Daily

**Remove:**No recommendation

**Change:**Daily

**First Aid**

(See procedures (firstaid.html))

**Eye:**Irrigate immediately

**Breathing:**Fresh air

**Respirator Recommendations**

(See Appendix E) ([nengapdx.html](#)).

**NIOSH**

**At concentrations above the NIOSH REL, or where there is no REL, at any detectable concentration:**

(APF = 10,000) Any self-contained breathing apparatus that has a full facepiece and is operated in a pressure-demand or other positive-pressure mode

(APF = 10,000) Any supplied-air respirator that has a full facepiece and is operated in a pressure-demand or other positive-pressure mode in combination with an auxiliary self-contained positive-pressure breathing apparatus

**Escape:**

(APF = 50) Any air-purifying, full-facepiece respirator with an N100, R100, or P100 filter.

[Click here \(pgintrod.html#nrp\)](#) for information on selection of N, R, or P filters.

Any appropriate escape-type, self-contained breathing apparatus

[Important additional information about respirator selection \(pgintrod.html#mustread\)](#)

**See also**

INTRODUCTION

**Follow NIOSH**

Facebook (<http://www.facebook.com/NIOSH>)

Flickr (<http://www.flickr.com/photos/NIOSH>)

Pinterest (<http://www.pinterest.com/cdcgov/workplace-safety-and-health/>)

Twitter (<http://twitter.com/NIOSH>)

YouTube (<http://www.youtube.com/user/NIOSHSafetyVideos>)

**NIOSH Homepage**

NIOSH A-Z

Workplace Safety & Health Topics

Publications and Products

Programs

Contact NIOSH

**File Formats Help:**

How do I view different file formats (PDF, DOC, PPT, MPEG) on this site?

(<https://www.cdc.gov/Other/plugins/>)

(<https://www.cdc.gov/Other/plugins/#pdf>)

---

Page last reviewed: April 11, 2016

Page last updated: April 11, 2016

Content source: National Institute for Occupational Safety and Health (NIOSH) (/niosh/) Education and Information Division

# Carbon monoxide



## Synonyms & Trade Names

Carbon oxide, Flue gas, Monoxide

### CAS No.

630-08-0

### RTECS No.

[FG3500000](#)

### DOT ID & Guide

1016 [119](#)

9202 [168](#) (cryogenic liquid)

## Formula

CO

## Conversion

1 ppm = 1.15 mg/m<sup>3</sup>

## IDLH

1200 ppm

See: [630080](#)

## Exposure Limits

### NIOSH REL

TWA 35 ppm (40 mg/m<sup>3</sup>) C 200 ppm (229 mg/m<sup>3</sup>)

### OSHA PEL

TWA 50 ppm (55 mg/m<sup>3</sup>) [See Appendix G](#)

## Measurement Methods

NIOSH [6604](#) ;

OSHA [ID209](#) , [ID210](#)

See: [NMAM](#) or [OSHA Methods](#)

## Physical Description

Colorless, odorless gas. [Note: Shipped as a nonliquefied or liquefied compressed gas.]

28.0

**Boiling Point**

-313°F

**Melting Point**

-337°F

**Solubility**

2%

**Vapor Pressure**

>35 atm

**Ionization Potential**

14.01 eV

**Flash Point**

NA (Gas)

**Upper Exposive Limit**

74%

**Lower Explosive Limit**

12.5%

**Relative Gas Density**

0.97

Flammable Gas

**Incompatibilities & Reactivities**

Strong oxidizers, bromine trifluoride, chlorine trifluoride, lithium

**Exposure Routes**

inhalation, skin and/or eye contact (liquid)

headache, tachypnea, nausea, lassitude (weakness, exhaustion), dizziness, confusion, hallucinations; cyanosis; depressed S-T segment of electrocardiogram, angina, syncope

### **Target Organs**

cardiovascular system, lungs, blood, central nervous system

### **Personal Protection/Sanitation**

(See [protection codes](#))

**Skin:**Frostbite

**Eyes:**Frostbite

**Wash skin:**No recommendation

**Remove:**When wet (flammable)

**Change:**No recommendation

**Provide:**Frostbite wash

### **First Aid**

(See [procedures](#))

**Eye:**Frostbite

**Skin:**Frostbite

**Breathing:**Respiratory support

### **Respirator Recommendations**

#### **NIOSH**

#### **Up to 350 ppm:**

(APF = 10) Any supplied-air respirator

#### **Up to 875 ppm:**

(APF = 25) Any supplied-air respirator operated in a continuous-flow mode

#### **Up to 1200 ppm:**

(APF = 50) Any air-purifying, full-facepiece respirator (gas mask) with a chin-style, front- or back-mounted canister providing protection against the compound of concern†

(APF = 50) Any self-contained breathing apparatus with a full facepiece

(APF = 50) Any supplied-air respirator with a full facepiece

#### **Emergency or planned entry into unknown**

(APF = 10,000) Any self-contained breathing apparatus that has a full facepiece and is operated in a pressure-demand or other positive-pressure mode  
(APF = 10,000) Any supplied-air respirator that has a full facepiece and is operated in a pressure-demand or other positive-pressure mode in combination with an auxiliary self-contained positive-pressure breathing apparatus

**Escape:**

(APF = 50) Any air-purifying, full-facepiece respirator (gas mask) with a chin-style, front- or back-mounted canister providing protection against the compound of concern†

Any appropriate escape-type, self-contained breathing apparatus

[Important additional information about respirator selection](#)

**See also**

[INTRODUCTION](#) ICSC CARD: [0023](#) [MEDICAL TESTS: 0040](#)

(/niosh/index.htm)

## Chlorodiphenyl (54% chlorine)

### Synonyms & Trade Names

Aroclor® 1254, PCB [Chlorodiphenyl (54% chlorine)], Polychlorinated biphenyl [Chlorodiphenyl (54% chlorine)]

### CAS No.

11097-69-1

### RTECS No.

TQ1360000

### DOT ID & Guide

2315 171

### Formula

$C_6H_3Cl_2C_6H_2Cl_3$  (approx)

### Conversion

### IDLH

Ca [5 mg/m<sup>3</sup>]

See: IDLH INDEX



**Exposure Limits****NIOSH REL**

Ca TWA 0.001 mg/m<sup>3</sup> See Appendix A (nengapdx.html) [\*Note: The REL also applies to other PCBs.]

**OSHA PEL**

TWA 0.5 mg/m<sup>3</sup> [skin]

**Measurement Methods**

**NIOSH** 5503 ;

**OSHA** PV2088

See: NMAM or OSHA Methods

**Physical Description**

Colorless to pale-yellow, viscous liquid or solid (below 50°F) with a mild, hydrocarbon odor.

**Molecular Weight**

326 (approx)

**Boiling Point**

689-734°F

**Freezing Point**

50°F

**Solubility**

Insoluble

**Vapor Pressure**

0.00006 mmHg

**Ionization Potential**

?

**Specific Gravity**

(77°F): 1.38

**Flash Point**

NA

**Upper Explosive Limit**

NA

**Lower Explosive Limit**

NA

Nonflammable Liquid, but exposure in a fire results in the formation of a black soot containing PCBs, polychlorinated dibenzofurans, and chlorinated dibenzo-p-dioxins.

#### **Incompatibilities & Reactivities**

Strong oxidizers

#### **Exposure Routes**

inhalation, skin absorption, ingestion, skin and/or eye contact

#### **Symptoms**

irritation eyes, chloracne; liver damage; reproductive effects; [potential occupational carcinogen]

#### **Target Organs**

Skin, eyes, liver, reproductive system

#### **Cancer Site**

[in animals: tumors of the pituitary gland & liver, leukemia]

#### **Personal Protection/Sanitation**

(See protection codes (protect.html))

**Skin:**Prevent skin contact

**Eyes:**Prevent eye contact

**Wash skin:**When contaminated

**Remove:**When wet or contaminated

**Change:**Daily

**Provide:**Eyewash, Quick drench

#### **First Aid**

(See procedures (firstaid.html))

**Eye:**Irrigate immediately

**Skin:**Soap wash immediately

**Breathing:**Respiratory support

**Swallow:**Medical attention immediately

#### **Respirator Recommendations**

#### **NIOSH**

**At concentrations above the NIOSH REL, or where there is no REL, at any detectable concentration:**

(APF = 10,000) Any self-contained breathing apparatus that has a full facepiece and is operated in a pressure-demand or other positive-pressure mode

(APF = 10,000) Any supplied-air respirator that has a full facepiece and is operated in a pressure-demand or other positive-pressure mode in combination with an auxiliary self-contained positive-pressure breathing apparatus

### **Escape:**

(APF = 50) Any air-purifying, full-facepiece respirator (gas mask) with a chin-style, front- or back-mounted organic vapor canister having an N100, R100, or P100 filter.

[Click here \(pgintrod.html#nrp\)](#) for information on selection of N, R, or P filters.

Any appropriate escape-type, self-contained breathing apparatus

[Important additional information about respirator selection \(pgintrod.html#mustread\)](#)

### **See also**

INTRODUCTION ICSC CARD: 0939 MEDICAL TESTS: 0176

### **Follow NIOSH**

Facebook (<http://www.facebook.com/NIOSH>)

Flickr (<http://www.flickr.com/photos/NIOSH>)

Pinterest (<http://www.pinterest.com/cdcgov/workplace-safety-and-health/>)

Twitter (<http://twitter.com/NIOSH>)

YouTube (<http://www.youtube.com/user/NIOSHSafetyVideos>)

### **NIOSH Homepage**

NIOSH A-Z

Workplace Safety & Health Topics

Publications and Products

Programs

Contact NIOSH

### **File Formats Help:**

How do I view different file formats (PDF, DOC, PPT, MPEG) on this site?

(<https://www.cdc.gov/Other/plugins/>)

Page last reviewed: April 11, 2016

Page last updated: April 11, 2016

Content source: National Institute for Occupational Safety and Health (NIOSH) (/niosh/) Education and Information Division

(/niosh/index.htm)

## Chromic acid and chromates

### Synonyms & Trade Names

Chromic acid (CrO<sub>3</sub>), Chromic anhydride, Chromic oxide, Chromium(VI) oxide (1:3), Chromium trioxide, Zinc chromate

### CAS No.

1333-82-0 (CrO<sub>3</sub>)

### RTECS No.

GB6650000 (CrO<sub>3</sub>)

### DOT ID & Guide

1755 154(acid solution)

1463 141(acid, solid)

### Formula

CrO<sub>3</sub> (acid)

### Conversion

### IDLH

Ca [15 mg/m<sup>3</sup> {as Cr(VI)}]

See: 1333820

**Exposure Limits****NIOSH REL**

(as Cr): Ca TWA 0.0002 mg/m<sup>3</sup> (8-hours) See Appendix A ([nengapdxa.html](#)) See Appendix C ([nengapdxc.html](#))

**OSHA PEL**

(as CrO<sub>3</sub>): TWA 0.005 mg/m<sup>3</sup> See Appendix C ([nengapdxc.html](#))

**Measurement Methods**

**NIOSH** [7600](#) , [7604](#) , [7605](#) , [7703](#) , [9101](#) ;

**OSHA** ID103 , ID215 , W4001

See: NMAM or OSHA Methods

**Physical Description**

CrO<sub>3</sub>: Dark-red, odorless flakes or powder. [Note: Often used in an aqueous solution (H<sub>2</sub>CrO<sub>4</sub>).]

**Molecular Weight**

100.0

**Boiling Point**

482°F (Decomposes)

**Melting Point**

387°F (Decomposes)

**Solubility**

63%

**Vapor Pressure**

Very low

**Ionization Potential**

NA

**Specific Gravity**

2.70 (CrO<sub>3</sub>)

**Flash Point**

NA

**Upper Explosive Limit**

NA

**Lower Explosive Limit**

NA



CrO<sub>3</sub>: Noncombustible Solid, but will accelerate the burning of combustible materials.

### **Incompatibilities & Reactivities**

Combustible, organic, or other readily oxidizable materials (paper, wood, sulfur, aluminum, plastics, etc.); corrosive to metals

### **Exposure Routes**

inhalation, ingestion, skin and/or eye contact

### **Symptoms**

irritation respiratory system; nasal septum perforation; liver, kidney damage; leukocytosis (increased blood leukocytes), leukopenia (reduced blood leukocytes), eosinophilia; eye injury, conjunctivitis; skin ulcer, sensitization dermatitis; [potential occupational carcinogen]

### **Target Organs**

Blood, respiratory system, liver, kidneys, eyes, skin

### **Cancer Site**

[lung cancer]

### **Personal Protection/Sanitation**

(See protection codes (protect.html))

**Skin:**Prevent skin contact

**Eyes:**Prevent eye contact

**Wash skin:**When contaminated

**Remove:**When wet or contaminated

**Change:**Daily

**Provide:**Eyewash, Quick drench

### **First Aid**

(See procedures (firstaid.html))

**Eye:**Irrigate immediately

**Skin:**Soap flush immediately

**Breathing:**Respiratory support

**Swallow:**Medical attention immediately

### **Respirator Recommendations**

**NIOSH**

**At concentrations above the NIOSH REL, or where there is no REL, at any detectable concentration:**

(APF = 10,000) Any self-contained breathing apparatus that has a full facepiece and is operated in a pressure-demand or other positive-pressure mode

(APF = 10,000) Any supplied-air respirator that has a full facepiece and is operated in a pressure-demand or other positive-pressure mode in combination with an auxiliary self-contained positive-pressure breathing apparatus

**Escape:**

(APF = 50) Any air-purifying, full-facepiece respirator with an N100, R100, or P100 filter.

[Click here \(pgintrod.html#nrp\)](#) for information on selection of N, R, or P filters.

Any appropriate escape-type, self-contained breathing apparatus

[Important additional information about respirator selection \(pgintrod.html#mustread\)](#)

**See also**

INTRODUCTION ICSC CARD: 1194 MEDICAL TESTS: 0051

**Follow NIOSH**

Facebook (<http://www.facebook.com/NIOSH>)

Flickr (<http://www.flickr.com/photos/NIOSH>)

Pinterest (<http://www.pinterest.com/cdcgov/workplace-safety-and-health/>)

Twitter (<http://twitter.com/NIOSH>)

YouTube (<http://www.youtube.com/user/NIOSHSafetyVideos>)

**NIOSH Homepage**

NIOSH A-Z

Workplace Safety & Health Topics

Publications and Products

Programs

Contact NIOSH

**File Formats Help:**

How do I view different file formats (PDF, DOC, PPT, MPEG) on this site?

(<https://www.cdc.gov/Other/plugins/>)

(<https://www.cdc.gov/Other/plugins/#pdf>)

---

Page last reviewed: April 11, 2016

Page last updated: April 11, 2016

Content source: National Institute for Occupational Safety and Health (NIOSH) (/niosh/) Education and Information Division

# Chromium metal



## Synonyms & Trade Names

Chrome, Chromium

### CAS No.

7440-47-3

### RTECS No.

[GB4200000](#)

### DOT ID & Guide

### Formula

Cr

### Conversion

### IDLH

250 mg/m<sup>3</sup> (as Cr)

See: [7440473](#)

### Exposure Limits

#### NIOSH REL

TWA 0.5 mg/m<sup>3</sup> [See Appendix C](#)

#### OSHA PEL

TWA 1 mg/m<sup>3</sup> [See Appendix C](#) [\*Note: The PEL also applies to insoluble chromium salts.]

### Measurement Methods

NIOSH [7024](#) , [7300](#) , [7301](#) , [7303](#)

, [9102](#) ;

OSHA [ID121](#) , [ID125G](#)

See: [NMAM](#) or [OSHA Methods](#)

### Physical Description

Blue-white to steel-gray, lustrous, brittle, hard, odorless solid.

**Boiling Point**

4788°F

**Melting Point**

3452°F

**Solubility**

Insoluble

**Vapor Pressure**

0 mmHg (approx)

**Ionization Potential**

NA

**Specific Gravity**

7.14

**Flash Point**

NA

**Upper Exposive Limit**

NA

**Lower Explosive Limit**

NA

Noncombustible Solid in bulk form, but finely divided dust burns rapidly if heated in a flame.

**Incompatibilities & Reactivities**

Strong oxidizers (such as hydrogen peroxide), alkalis

**Exposure Routes**

inhalation, ingestion, skin and/or eye contact

**Symptoms**

## Target Organs

Eyes, skin, respiratory system

## Personal Protection/Sanitation

(See [protection codes](#))

**Skin:**No recommendation

**Eyes:**No recommendation

**Wash skin:**No recommendation

**Remove:**No recommendation

**Change:**No recommendation

## First Aid

(See [procedures](#))

**Eye:**Irrigate immediately

**Skin:**Soap wash

**Breathing:**Respiratory support

**Swallow:**Medical attention immediately

## Respirator Recommendations

### NIOSH

#### Up to 2.5 mg/m<sup>3</sup>:

(APF = 5) Any quarter-mask respirator.

[Click here](#) for information on selection of N, R, or P filters.\*

#### Up to 5 mg/m<sup>3</sup>:

(APF = 10) Any particulate respirator equipped with an N95, R95, or P95 filter (including N95, R95, and P95 filtering facepieces) except quarter-mask respirators.

The following filters may also be used: N99, R99, P99, N100, R100, P100.

[Click here](#) for information on selection of N, R, or P filters.\*

(APF = 10) Any supplied-air respirator\*

#### Up to 12.5 mg/m<sup>3</sup>:

(APF = 25) Any supplied-air respirator operated in a continuous-flow mode\*

(APF = 25) Any powered, air-purifying respirator with a high-efficiency particulate filter.\*

#### Up to 25 mg/m<sup>3</sup>:

with an N100, R100, or P100 filter.

[Click here](#) for information on selection of N, R, or P filters.

(APF = 50) Any powered, air-purifying respirator with a tight-fitting facepiece and a high-efficiency particulate filter\*

(APF = 50) Any self-contained breathing apparatus with a full facepiece

(APF = 50) Any supplied-air respirator with a full facepiece

**Up to 250 mg/m<sup>3</sup>:**

(APF = 2000) Any supplied-air respirator that has a full facepiece and is operated in a pressure-demand or other positive-pressure mode

**Emergency or planned entry into unknown concentrations or IDLH conditions:**

(APF = 10,000) Any self-contained breathing apparatus that has a full facepiece and is operated in a pressure-demand or other positive-pressure mode

(APF = 10,000) Any supplied-air respirator that has a full facepiece and is operated in a pressure-demand or other positive-pressure mode in combination with an auxiliary self-contained positive-pressure breathing apparatus

**Escape:**

(APF = 50) Any air-purifying, full-facepiece respirator with an N100, R100, or P100 filter.

[Click here](#) for information on selection of N, R, or P filters.

Any appropriate escape-type, self-contained breathing apparatus

[Important additional information about respirator selection](#)

**See also**

[INTRODUCTION](#) ICSC CARD: [0029](#)

(/niosh/index.htm)

## Coal tar pitch volatiles

### Synonyms & Trade Names

Acridine, Anthracene, Benzo(a)pyrene, Chrysene, Coal tar, Phenanthrene, pyrene [Note: NIOSH considers coal tar, coal tar pitch, and creosote to be coal tar products.]

#### CAS No.

65996-93-2

#### RTECS No.

GF8655000

#### DOT ID & Guide

2713 153(acridine)

#### Formula

#### Conversion

#### IDLH

Ca [80 mg/m<sup>3</sup>]

See: 65996932



**Exposure Limits****NIOSH REL**

Ca TWA 0.1 mg/m<sup>3</sup> (cyclohexane-extractable fraction) See Appendix A ([nengapdxa.html](#)) See Appendix C ([nengapdxc.html](#))

**OSHA PEL**

TWA 0.2 mg/m<sup>3</sup> (benzene-soluble fraction) [1910.1002] See Appendix C ([nengapdxc.html](#))

**Measurement Methods****OSHA 58**

See: NMAM or OSHA Methods

**Physical Description**

Black or dark-brown amorphous residue.

**Molecular Weight**

Properties vary depending upon the specific compound.



## Combustible Solids

### Incompatibilities & Reactivities

Strong oxidizers

### Exposure Routes

inhalation, skin and/or eye contact

### Symptoms

dermatitis, bronchitis, [potential occupational carcinogen]

### Target Organs

respiratory system, skin, bladder, kidneys

### Cancer Site

[lung, kidney & skin cancer]

### Personal Protection/Sanitation

(See protection codes (protect.html))

**Skin:**Prevent skin contact

**Eyes:**Prevent eye contact

**Wash skin:**Daily

**Remove:**No recommendation

**Change:**Daily

### First Aid

(See procedures (firstaid.html))

**Eye:**Irrigate immediately

**Skin:**Soap wash immediately

**Breathing:**Respiratory support

**Swallow:**Medical attention immediately

### Respirator Recommendations

#### NIOSH

**At concentrations above the NIOSH REL, or where there is no REL, at any detectable concentration:**

(APF = 10,000) Any self-contained breathing apparatus that has a full facepiece and is operated in a pressure-demand or other positive-pressure mode

(APF = 10,000) Any supplied-air respirator that has a full facepiece and is operated in a pressure-demand or other positive-pressure mode in combination with an auxiliary self-contained positive-pressure breathing apparatus

**Escape:**

(APF = 50) Any air-purifying, full-facepiece respirator (gas mask) with a chin-style, front- or back-mounted organic vapor canister having an N100, R100, or P100 filter.

[Click here \(pgintrod.html#nrp\)](#) for information on selection of N, R, or P filters.

Any appropriate escape-type, self-contained breathing apparatus

[Important additional information about respirator selection \(pgintrod.html#mustread\)](#)

**See also**

INTRODUCTION ICSC CARD: 1415 MEDICAL TESTS: 0054

**Follow NIOSH**

Facebook (<http://www.facebook.com/NIOSH>)

Flickr (<http://www.flickr.com/photos/NIOSH>)

Pinterest (<http://www.pinterest.com/cdcgov/workplace-safety-and-health/>)

Twitter (<http://twitter.com/NIOSH>)

YouTube (<http://www.youtube.com/user/NIOSHSafetyVideos>)

**NIOSH Homepage**

NIOSH A-Z

Workplace Safety & Health Topics

Publications and Products

Programs

Contact NIOSH

Page last reviewed: April 11, 2016

Page last updated: April 11, 2016

Content source: National Institute for Occupational Safety and Health (NIOSH) (/niosh/) Education and Information Division

# Hydrogen sulfide



## Synonyms & Trade Names

Hydrosulfuric acid, Sewer gas, Sulfuretted hydrogen

### CAS No.

7783-06-4

### RTECS No.

[MX1225000](#)

### DOT ID & Guide

1053 [117](#)

## Formula

H<sub>2</sub>S

## Conversion

1 ppm = 1.40 mg/m<sup>3</sup>

## IDLH

100 ppm

See: [7783064](#)

## Exposure Limits

### NIOSH REL

C 10 ppm (15 mg/m<sup>3</sup>) [10-minute]

### OSHA PEL

C 20 ppm 50 ppm [10-minute maximum peak] See [Appendix G](#)

## Measurement Methods

NIOSH [6013](#) ;

OSHA ID141

See: [NMAM](#) or [OSHA Methods](#)

## Physical Description

Colorless gas with a strong odor of rotten eggs. [Note: Sense of smell becomes rapidly fatigued & can NOT be relied upon to warn of the continuous presence of H<sub>2</sub>S. Shipped as a liquefied compressed gas.]

**Molecular Weight**

34.1

**Boiling Point**

-77°F

**Freezing Point**

-122°F

**Solubility**

0.4%

**Vapor Pressure**

17.6 atm

**Ionization Potential**

10.46 eV

**Flash Point**

NA (Gas)

**Upper Exposive Limit**

44.0%

**Lower Explosive Limit**

4.0%

**Relative Gas Density**

1.19

Flammable Gas

**Incompatibilities & Reactivities**

Strong oxidizers, strong nitric acid, metals

**Exposure Routes**

inhalation, skin and/or eye contact

irritation eyes, respiratory system; apnea, coma, convulsions; conjunctivitis, eye pain, lacrimation (discharge of tears), photophobia (abnormal visual intolerance to light), corneal vesiculation; dizziness, headache, lassitude (weakness, exhaustion), irritability, insomnia; gastrointestinal disturbance; liquid: frostbite

### Target Organs

Eyes, respiratory system, central nervous system

### Personal Protection/Sanitation

(See [protection codes](#))

**Skin:**Frostbite

**Eyes:**Frostbite

**Wash skin:**No recommendation

**Remove:**When wet (flammable)

**Change:**No recommendation

**Provide:**Frostbite wash

### First Aid

(See [procedures](#))

**Eye:**Frostbite

**Skin:**Frostbite

**Breathing:**Respiratory support

### Respirator Recommendations

#### NIOSH

#### Up to 100 ppm:

(APF = 25) Any powered, air-purifying respirator with cartridge(s) providing protection against the compound of concern

(APF = 50) Any air-purifying, full-facepiece respirator (gas mask) with a chin-style, front- or back-mounted canister providing protection against the compound of concern

(APF = 10) Any supplied-air respirator\*

(APF = 50) Any self-contained breathing apparatus with a full facepiece

#### Emergency or planned entry into unknown concentrations or IDLH conditions:

(APF = 10,000) Any self-contained breathing apparatus that has a full facepiece and is operated in

(APF = 10,000) Any supplied-air respirator that has a full facepiece and is operated in a pressure-demand or other positive-pressure mode in combination with an auxiliary self-contained positive-pressure breathing apparatus

**Escape:**

(APF = 50) Any air-purifying, full-facepiece respirator (gas mask) with a chin-style, front- or back-mounted canister providing protection against the compound of concern

Any appropriate escape-type, self-contained breathing apparatus

[Important additional information about respirator selection](#)

**See also**

[INTRODUCTION](#) ICSC CARD: [0165](#)



# Lead



## Synonyms & Trade Names

Lead metal, Plumbum

### CAS No.

7439-92-1

### RTECS No.

[OF7525000](#)

### DOT ID & Guide

## Formula

Pb

## Conversion

### IDLH

100 mg/m<sup>3</sup> (as Pb)

See: [7439921](#)

## Exposure Limits

### NIOSH REL

TWA (8-hour) 0.050 mg/m<sup>3</sup> [See Appendix C](#) [\*Note: The REL also applies to other lead compounds (as Pb) -- see Appendix C.]

### OSHA PEL

[1910.1025] TWA 0.050 mg/m<sup>3</sup> [See Appendix C](#) [\*Note: The PEL also applies to other lead compounds (as Pb) -- see Appendix C.]

## Measurement Methods

NIOSH [7082](#) , [7105](#) , [7300](#) , [7301](#)  
, [7303](#) , [7700](#) , [7701](#) , [7702](#) , [9100](#)  
, [9102](#) , [9105](#) ;

OSHA ID206 , ID121 , ID125G  
See: [NMAM](#) or [OSHA Methods](#)

## Physical Description

**Molecular Weight**

207.2

**Boiling Point**

3164°F

**Melting Point**

621°F

**Solubility**

Insoluble

**Vapor Pressure**

0 mmHg (approx)

**Ionization Potential**

NA

**Specific Gravity**

11.34

**Flash Point**

NA

**Upper Expositive Limit**

NA

**Lower Explosive Limit**

NA

Noncombustible Solid in bulk form.

**Incompatibilities & Reactivities**

Strong oxidizers, hydrogen peroxide, acids

**Exposure Routes**

inhalation, ingestion, skin and/or eye contact

## Symptoms

lassitude (weakness, exhaustion), insomnia; facial pallor; anorexia, weight loss, malnutrition; constipation, abdominal pain, colic; anemia; gingival lead line; tremor; paralysis wrist, ankles; encephalopathy; kidney disease; irritation eyes; hypertension

## Target Organs

Eyes, gastrointestinal tract, central nervous system, kidneys, blood, gingival tissue

## Personal Protection/Sanitation

(See [protection codes](#))

**Skin:**Prevent skin contact

**Eyes:**Prevent eye contact

**Wash skin:**Daily

**Remove:**When wet or contaminated

**Change:**Daily

## First Aid

(See [procedures](#))

**Eye:**Irrigate immediately

**Skin:**Soap flush promptly

**Breathing:**Respiratory support

**Swallow:**Medical attention immediately

## Respirator Recommendations

(See [Appendix E](#))

### NIOSH/OSHA

#### Up to 0.5 mg/m<sup>3</sup>:

(APF = 10) Any air-purifying respirator with an N100, R100, or P100 filter (including N100, R100, and P100 filtering facepieces) except quarter-mask respirators.

[Click here](#) for information on selection of N, R, or P filters.

(APF = 10) Any supplied-air respirator

#### Up to 1.25 mg/m<sup>3</sup>:

(APF = 25) Any supplied-air respirator operated in a continuous-flow mode

(APF = 25) Any powered, air-purifying respirator with a high-efficiency particulate filter.

**Up to 2.5 mg/m<sup>3</sup>:**

(APF = 50) Any air-purifying, full-facepiece respirator with an N100, R100, or P100 filter.

[Click here](#) for information on selection of N, R, or P filters.

(APF = 50) Any supplied-air respirator that has a tight-fitting facepiece and is operated in a continuous-flow mode

(APF = 50) Any powered, air-purifying respirator with a tight-fitting facepiece and a high-efficiency particulate filter

(APF = 50) Any self-contained breathing apparatus with a full facepiece

(APF = 50) Any supplied-air respirator with a full facepiece

**Up to 50 mg/m<sup>3</sup>:**

(APF = 1000) Any supplied-air respirator operated in a pressure-demand or other positive-pressure mode

**Up to 100 mg/m<sup>3</sup>:**

(APF = 2000) Any supplied-air respirator that has a full facepiece and is operated in a pressure-demand or other positive-pressure mode

**Emergency or planned entry into unknown concentrations or IDLH conditions:**

(APF = 10,000) Any self-contained breathing apparatus that has a full facepiece and is operated in a pressure-demand or other positive-pressure mode

(APF = 10,000) Any supplied-air respirator that has a full facepiece and is operated in a pressure-demand or other positive-pressure mode in combination with an auxiliary self-contained positive-pressure breathing apparatus

**Escape:**

(APF = 50) Any air-purifying, full-facepiece respirator with an N100, R100, or P100 filter.

[Click here](#) for information on selection of N, R, or P filters.

Any appropriate escape-type self-contained breathing

[Important additional information about respirator selection](#)

**See also**

[INTRODUCTION](#) [ICSC CARD: 0052](#) [MEDICAL TESTS: 0127](#)

# Mercury compounds [except (organo) alkyls] (as Hg)



## Synonyms & Trade Names

Colloidal mercury, Mercury metal, Metallic mercury, Quicksilver

### CAS No.

7439-97-6 (metal)

### RTECS No.

OV4550000 (metal)

### DOT ID & Guide

2809 172 (metal)

## Formula

Hg (metal)

## Conversion

### IDLH

10 mg/m<sup>3</sup> (as Hg)

See: [7439976](#)

## Exposure Limits

### NIOSH REL

NIOSH REL:

Hg Vapor: TWA 0.05 mg/m<sup>3</sup> [skin]

Other: C 0.1 mg/m<sup>3</sup> [skin]

### OSHA PEL

TWA 0.1 mg/m<sup>3</sup> [See Appendix G](#)

## Measurement Methods

NIOSH [6009](#) ;

OSHA ID140

See: [NMAM](#) or [OSHA Methods](#)

## Physical Description

Metal: Silver-white, heavy, odorless liquid. [Note:

**Molecular Weight**

200.6

**Boiling Point**

674°F

**Freezing Point**

-38°F

**Solubility**

Insoluble

**Vapor Pressure**

0.0012 mmHg

**Ionization Potential**

?

**Specific Gravity**

13.6 (metal)

**Flash Point**

NA

**Upper Explosive Limit**

NA

**Lower Explosive Limit**

NA

Metal: Noncombustible Liquid

**Incompatibilities & Reactivities**

Acetylene, ammonia, chlorine dioxide, azides, calcium (amalgam formation), sodium carbide, lithium, rubidium, copper

**Exposure Routes**

inhalation, skin absorption, ingestion, skin and/or eye contact

### Symptoms

irritation eyes, skin; cough, chest pain, dyspnea (breathing difficulty), bronchitis, pneumonitis; tremor, insomnia, irritability, indecision, headache, lassitude (weakness, exhaustion); stomatitis, salivation; gastrointestinal disturbance, anorexia, weight loss; proteinuria

### Target Organs

Eyes, skin, respiratory system, central nervous system, kidneys

### Personal Protection/Sanitation

(See [protection codes](#))

**Skin:** Prevent skin contact

**Eyes:** No recommendation

**Wash skin:** When contaminated

**Remove:** When wet or contaminated

**Change:** Daily

### First Aid

(See [procedures](#))

**Eye:** Irrigate immediately

**Skin:** Soap wash promptly

**Breathing:** Respiratory support

**Swallow:** Medical attention immediately

### Respirator Recommendations

**Other mercury compounds:** NIOSH/OSHA

**Up to 1 mg/m<sup>3</sup>:**

(APF = 10) Any chemical cartridge respirator with cartridge(s) providing protection against the compound of concern†

(APF = 10) Any supplied-air respirator

**Up to 2.5 mg/m<sup>3</sup>:**

(APF = 25) Any supplied-air respirator operated in a continuous-flow mode

(APF = 25) Any powered, air-purifying respirator with cartridge(s) providing protection against the compound of concern†(canister)



**Up to 5 mg/m<sup>3</sup>:**

(APF = 50) Any chemical cartridge respirator with a full facepiece and cartridge(s) providing protection against the compound of concern†

(APF = 50) Any air-purifying, full-facepiece respirator (gas mask) with a chin-style, front- or back-mounted canister providing protection against the compound of concern†

(APF = 50) Any supplied-air respirator that has a tight-fitting facepiece and is operated in a continuous-flow mode

(APF = 50) Any powered, air-purifying respirator with a tight-fitting facepiece and cartridge(s) providing protection against the compound of concern (canister)

(APF = 50) Any self-contained breathing apparatus with a full facepiece

(APF = 50) Any supplied-air respirator with a full facepiece

**Up to 10 mg/m<sup>3</sup>:**

(APF = 1000) Any supplied-air respirator operated in a pressure-demand or other positive-pressure mode

**Emergency or planned entry into unknown concentrations or IDLH conditions:**

(APF = 10,000) Any self-contained breathing apparatus that has a full facepiece and is operated in a pressure-demand or other positive-pressure mode

(APF = 10,000) Any supplied-air respirator that has a full facepiece and is operated in a pressure-demand or other positive-pressure mode in combination with an auxiliary self-contained positive-pressure breathing apparatus

**Escape:**

(APF = 50) Any air-purifying, full-facepiece respirator (gas mask) with a chin-style, front- or back-mounted canister providing protection against the compound of concern

Any appropriate escape-type, self-contained breathing apparatus

[Important additional information about respirator selection](#)

**See also**

[INTRODUCTION](#) [ICSC CARD: 0056](#) [MEDICAL TESTS: 0136](#)

(/niosh/index.htm)

## Pentachlorophenol

### Synonyms & Trade Names

PCP, Penta, 2,3,4,5,6-Pentachlorophenol

#### CAS No.

87-86-5

#### RTECS No.

SM6300000

#### DOT ID & Guide

3155 154

#### Formula

$C_6Cl_5OH$

#### Conversion

#### IDLH

2.5 mg/m<sup>3</sup>  
See: 87865

**Exposure Limits****NIOSH REL**TWA 0.5 mg/m<sup>3</sup> [skin]**OSHA PEL**TWA 0.5 mg/m<sup>3</sup> [skin]**Measurement Methods****NIOSH** [5512](#)

See: NMAM or OSHA Methods

**Physical Description**

Colorless to white, crystalline solid with a benzene-like odor. [fungicide]

**Molecular Weight**

266.4

**Boiling Point**

588°F (Decomposes)

**Melting Point**

374°F

**Solubility**

0.001%

**Vapor Pressure**

(77°F): 0.0001 mmHg

**Ionization Potential**

NA

**Specific Gravity**

1.98

**Flash Point**

NA

**Upper Explosive Limit**

NA

**Lower Explosive Limit**

NA

Noncombustible Solid

## Incompatibilities & Reactivities

Strong oxidizers, acids, alkalis

## Exposure Routes

inhalation, skin absorption, ingestion, skin and/or eye contact

## Symptoms

irritation eyes, nose, throat; sneezing, cough; lassitude (weakness, exhaustion), anorexia, weight loss; sweating; headache, dizziness; nausea, vomiting; dyspnea (breathing difficulty), chest pain; high fever; dermatitis

## Target Organs

Eyes, skin, respiratory system, cardiovascular system, liver, kidneys, central nervous system

## Personal Protection/Sanitation

(See protection codes (protect.html))

**Skin:**Prevent skin contact

**Eyes:**Prevent eye contact

**Wash skin:**When contaminated

**Remove:**When wet or contaminated

**Change:**Daily

**Provide:**Eyewash, Quick drench

## First Aid

(See procedures (firstaid.html))

**Eye:**Irrigate immediately

**Skin:**Soap wash immediately

**Breathing:**Respiratory support

**Swallow:**Medical attention immediately

## Respirator Recommendations

### NIOSH/OSHA

#### Up to 2.5 mg/m<sup>3</sup>:

(APF = 10) Any air-purifying half-mask respirator with organic vapor cartridge(s) in combination with an N95, R95, or P95 filter. The following filters may also be used: N99, R99, P99, N100, R100, P100.

[Click here \(pgintrod.html#nrp\)](#) for information on selection of N, R, or P filters.\*

(APF = 25) Any powered, air-purifying respirator with an organic vapor cartridge in combination with a high-

efficiency particulate filter.\*

(APF = 10) Any supplied-air respirator\*

(APF = 50) Any self-contained breathing apparatus with a full facepiece

**Emergency or planned entry into unknown concentrations or IDLH conditions:**

(APF = 10,000) Any self-contained breathing apparatus that has a full facepiece and is operated in a pressure-demand or other positive-pressure mode

(APF = 10,000) Any supplied-air respirator that has a full facepiece and is operated in a pressure-demand or other positive-pressure mode in combination with an auxiliary self-contained positive-pressure breathing apparatus

**Escape:**

(APF = 50) Any air-purifying, full-facepiece respirator (gas mask) with a chin-style, front- or back-mounted organic vapor canister having an N100, R100, or P100 filter.

[Click here \(pgintrod.html#nrp\)](#) for information on selection of N, R, or P filters.

Any appropriate escape-type, self-contained breathing apparatus

[Important additional information about respirator selection \(pgintrod.html#mustread\)](#)

**See also**

INTRODUCTION ICSC CARD: 0069 MEDICAL TESTS: 0178

**Follow NIOSH**

Facebook (<http://www.facebook.com/NIOSH>)

Flickr (<http://www.flickr.com/photos/NIOSH>)

Pinterest (<http://www.pinterest.com/cdcgov/workplace-safety-and-health/>)

Twitter (<http://twitter.com/NIOSH>)

YouTube (<http://www.youtube.com/user/NIOSHSafetyVideos>)

**NIOSH Homepage**

NIOSH A-Z

Workplace Safety & Health Topics

Publications and Products

Programs

Contact NIOSH

---

## **File Formats Help:**

How do I view different file formats (PDF, DOC, PPT, MPEG) on this site?

(<https://www.cdc.gov/Other/plugins/>)

(<https://www.cdc.gov/Other/plugins/#pdf>)

---

Page last reviewed: April 11, 2016

Page last updated: April 11, 2016

Content source: National Institute for Occupational Safety and Health (NIOSH) (/niosh/) Education and Information Division



## **APPENDIX S**

### **Example of Cal/OSHA Training Requirements**

**CALIFORNIA OSHA GENERAL TRAINING REQUIREMENTS**  
 (REFERENCE [https://www.dir.ca.gov/dosh/dosh\\_publications/trainingreq.htm](https://www.dir.ca.gov/dosh/dosh_publications/trainingreq.htm))

Training Topic	T8 Section	Frequency of Training	Typical Job Classification	Cal/OSHA Publication
Accident Investigation	<a href="#">3203(a)(7)(F)</a>	Initial	Supervisors/Accident Investigators	Model Program(s) IIPP:  <a href="#">For High Hazard Employers</a>  <a href="#">For Non-High Hazard Employers</a>  For Employers with Intermittent Employees ( <a href="#">English</a> & <a href="#">Spanish</a> )  For Employers With Intermittent Workers in Agriculture ( <a href="#">English</a> & <a href="#">Spanish</a> ) <a href="#">Guide to Developing IIPP</a>
Accident Prevention Signs & Tags	<a href="#">3341(d)(5)</a>	Initial	Impacted Employees	<a href="#">Lockout/Blockout</a>
Acetylene Fuel & Gas Safety	<a href="#">1740(k)(1)</a>	Initial	Users	
Acrylonitrile (AN)	<a href="#">5213(o)</a> <a href="#">5213 (appendix B)</a>	Initial Annual	Exposed Employees Qualified Person	
Actinolite (Non-Asbestos)	<a href="#">5208.1</a>	Initial Annual	Exposed Employees	
Anthophyllite (Non-Asbestos)	<a href="#">5208.1(n)</a>	Initial Annual	Exposed Employees	
Agricultural & Equipment Tractors	<a href="#">3441(a)</a> <a href="#">3664(b)</a>	Initial Annual	Involved Employees Operators	<a href="#">Agricultural - Industrial Tractors</a>  <a href="#">Farm Labor Contractors Guide</a>
Asbestos Consultant Site Surveillance Technician	<a href="#">341.15</a>	Initial	Certified Persons	
Asbestos/Asbestos Awareness	<a href="#">1529(k)(9)(B)</a> <a href="#">5208(j)(7)(B)</a> <a href="#">1529</a>	Initial Annual	Employees likely exposed =>PEL & those who perform Class I-IV operations	
Building Inspector Project Designer	<a href="#">341.16</a>  <a href="#">341.17</a>	Initial  Initial	Assigned  Exposed Employees	
Cement Pipe	<a href="#">1529(o)(4)</a>	Initial Annual	Competent Person	
Class I-IV Operations	<a href="#">341.9</a>	Initial Annual	Qualified Person	
Battery Handling/ Changing/Charging	<a href="#">5185(a)</a>	Initial	Assigned Employees	

**CALIFORNIA OSHA GENERAL TRAINING REQUIREMENTS**  
(REFERENCE [https://www.dir.ca.gov/dosh/dosh\\_publications/trainingreq.htm](https://www.dir.ca.gov/dosh/dosh_publications/trainingreq.htm))

Training Topic	T8 Section	Frequency of Training	Typical Job Classification	Cal/OSHA Publication
Benzene	<a href="#">5218(i) &amp; (j)(3)</a>	Initial Annual	Exposed Employees	
Bloodborne Pathogens	<a href="#">5193(g)(2)</a>	Initial Annual	Potentially Exposed Employees	<a href="#">A Best Practices Approach for Reducing Bloodborne Pathogens Exposure</a> <a href="#">Exposure Control Plan for Bloodborne Pathogens</a>
1,3-Butadiene	<a href="#">5201(l)(2)</a>	Initial Annual	Exposed Employees	
Cadmium	<a href="#">5207(m)(4)</a> <a href="#">1532</a>	Initial Annual	Exposed Employees Competent Person	
Carcinogens As Listed	<a href="#">5209(e)(5)</a>	Initial	Exposed Employees	
Chromium VI	<a href="#">1532.2</a>	Initial Annual	Exposed Employees	
Compaction Equipment	<a href="#">4355(a)(2)</a>	Before Use	Users	
Control of Hazardous Energy	<a href="#">3314(j)</a>	Initial	Authorized Employees	<a href="#">Lockout/Blockout</a>
Cranes & Other Hoisting Equipment Incl. Mobile/ Tower/ Derrick	<a href="#">5006.1(a)</a> <a href="#">5006</a> <a href="#">4966</a> , <a href="#">4994</a> , <a href="#">4999</a> , <a href="#">5000</a> , <a href="#">5004</a> , <a href="#">5031</a> , <a href="#">5043</a> , <a href="#">5044</a>	Initial Mobile & Tower Cert. @ 5 yrs	Mobile & Tower Crane Operators Qualified Person Authorized Employees	
Demolition	<a href="#">1734</a> <a href="#">1735(u)</a> <a href="#">1736</a>		Qualified Person	
1,2 Dibromo-3-Chloropropane (DBCP)	<a href="#">5212(i)(3) &amp; (n)</a> <a href="#">5212 (Appendix B)</a>	Initial Annual	Exposed Employees Qualified Person	
Diving Operations	<a href="#">6052</a>	Initial	Assigned Employees	
Elevating Work Platforms & Aerial Devices	<a href="#">3648(l)(7)</a> <a href="#">3648(c)</a> <a href="#">3646(c)</a> <a href="#">3638(d)</a>	Before Use	Users Authorized Personnel	
Emergency Action Plan	<a href="#">3220(e)</a>	Initial Plan Update	Impacted Employees	
Emergency Procedures (Construction)	<a href="#">1512(d)</a>	Initial	Assigned Employees	
Equipment & Machinery (Construction)	<a href="#">1510(b)</a>	Initial	Qualified Person	
Erection & Construction - Bolting/ Riveting/	<a href="#">1716</a> <a href="#">1716.1</a> <a href="#">1716.1(f)(1)</a>	Initial	Assigned Employees Competent Person Qualified Person	Pocket Guide for the Construction Industry ( <a href="#">English</a> / <a href="#">Spanish</a> )

**CALIFORNIA OSHA GENERAL TRAINING REQUIREMENTS**  
 (REFERENCE [https://www.dir.ca.gov/dosh/dosh\\_publications/trainingreq.htm](https://www.dir.ca.gov/dosh/dosh_publications/trainingreq.htm))

Training Topic	T8 Section	Frequency of Training	Typical Job Classification	Cal/OSHA Publication
Plumbing Structural Wood/ Steel Frame Steel Erection	<a href="#">1716.2(j)</a> <a href="#">1710</a>			
Ergonomics	<a href="#">5110(b)(3)</a>	Initial - When Standard is Triggered	Employees in affected job classifications (identical jobs) when standard is triggered	<a href="#">Back Injury Prevention Guide in the Health Care Industry for Health Care Providers</a>  <a href="#">Easy Ergonomics</a>  <a href="#">Ergonomics in Action</a>  <a href="#">Fitting The Task To The Person: Ergonomics for Very Small Businesses</a>  <a href="#">Easy Ergonomics for Desktop Computer Users</a>
Ethylene Dibromide (EDB)	<a href="#">5219(j)</a>	Initial Annual	Exposed Employees	
Excavation/ Trenching/ Shoring	<a href="#">1541</a>		Competent Person	<a href="#">Trenching Safety (Tailgate Topic)</a>  <a href="#">Pocket Guide for the Construction Industry</a>
Explosives	<a href="#">5239</a> <a href="#">5322</a> <a href="#">5329</a> <a href="#">344.20, 344.21</a>	Initial	Assigned Employees Competent Person Licensed Blaster	
Explosives - Deteriorated	<a href="#">5240</a>		Competent Person	
Explosives Storage Magazines	<a href="#">5256</a>		Competent Person	
Fall Protection	<a href="#">1671.1</a>	Initial	Affected Employees Competent Person Qualified Person	
Fire Brigades (Private)	<a href="#">3411(c)</a>	Initial/ Quarterly/ Annual Refresher	Assigned Employees	
Fire Extinguisher & Fire Fighting Equipment	<a href="#">6151(g)(1)-(2)</a>	Initial Annual	Assigned Employees	
Fire Prevention Plan	<a href="#">3221(d)(1)-(2)</a>	Initial New Hazards	Exposed Employees	
Fire Protection - Fixed Extinguishing Systems	<a href="#">6175(b)(10)</a> <a href="#">6181(b)(2)</a>	Initial Annual	Employees Assigned Maintenance/Operation Exposed Employees	

**CALIFORNIA OSHA GENERAL TRAINING REQUIREMENTS**  
 (REFERENCE [https://www.dir.ca.gov/dosh/dosh\\_publications/trainingreq.htm](https://www.dir.ca.gov/dosh/dosh_publications/trainingreq.htm))

Training Topic	T8 Section	Frequency of Training	Typical Job Classification	Cal/OSHA Publication
Fire Protection - Standpipe & Hose System Inspection	<a href="#">6165(f)(2)(F)</a>	Initial	Assigned Employees	
First Aid First Aid & CPR	<a href="#">3439(b)</a> <a href="#">6251(d)(2)</a> <a href="#">3400(b)</a> <a href="#">5157, 5158, 5193</a> <a href="#">3421, 6052</a>	Initial Changes Every 2 years (or as specified by cert. organization)	Assigned Employees Supervisors	
First Aid (Construction)	<a href="#">1512(b) &amp; (d)</a>	Initial Updated	Assigned Employees	
Flaggers (Traffic)	<a href="#">1599(f) &amp; (g)</a>	Initial	Assigned Employees	
Flammable Liquids/ Gasses/Vapors - Industrial Plants	<a href="#">5561</a>		Qualified Person	
Hazard Communication	<a href="#">5194(b)(1)</a>	Initial New chemicals or processes	Exposed Employees	<a href="#">Guide to California Hazard Communication Regulation</a>
Hazardous Substance Containers Clean/ Repair/Alter	<a href="#">5166(a)</a>	Initial	Assigned Employees	
Hazardous Waste Operations & Emergency Resp.	<a href="#">5192 (e) &amp; (q)(6)</a>	Initial Annual Refresher	Assigned Employees Qualified Person	
Hearing (Noise) Protectors Conservation	<a href="#">5098(a)(4)</a> <a href="#">5097(d)(5)(A)&amp;(B)</a> <a href="#">5099(a)</a>	Initial Retraining Initial Annual	Employees Provided Protectors All Employees Exposed to =>85 dBA TWA	
Heat Stress	<a href="#">3395</a>	Initial	Exposed Employees	Protect Yourself from Heat Illness ( <a href="#">English/Spanish</a> )
Helicopter Operations	<a href="#">1901(c)</a>	Daily Briefing	Involved Personnel	
Hexavalent Chromium	1532.2			
Industrial/Lift Trucks (Forklifts) & Tractors	<a href="#">3657(i)</a> <a href="#">3664(b)</a> <a href="#">3668</a>	Initial, Annual Observed Unsafe Operation Post Accident Equipment Change Workplace Change	Operators	Operating Rules for Industrial Trucks Poster ( <a href="#">English</a> / <a href="#">Spanish</a> )

**CALIFORNIA OSHA GENERAL TRAINING REQUIREMENTS**  
 (REFERENCE [https://www.dir.ca.gov/dosh/dosh\\_publications/trainingreq.htm](https://www.dir.ca.gov/dosh/dosh_publications/trainingreq.htm))

Training Topic	T8 Section	Frequency of Training	Typical Job Classification	Cal/OSHA Publication
		(Operator eval. @ 3 years)		
Injury & Illness Prevention Program	<a href="#">3203(a)(7)</a> <a href="#">1509(e)</a>	Initial Updated	All Employees Supervisor Tailgates	Model Program(s) IIPP:  <a href="#">For High Hazard Employers</a>  <a href="#">For Non-High Hazard Employers</a>  For Employers with Intermittent Employees ( <a href="#">English</a> & <a href="#">Spanish</a> )  For Employers With Intermittent Workers in Agriculture ( <a href="#">English</a> & <a href="#">Spanish</a> ) <a href="#">Guide to Developing IIPP</a>
Inorganic Arsenic	<a href="#">5214(m)</a>	Initial Annual	Exposed Employees	
Job Hazard(s)	<a href="#">3203(a)(7)</a> <a href="#">1510(a)</a>	Before Job Assignment New Hazards	All Employees	<a href="#">Guide to Developing IIPP</a>
Laser Equipment	<a href="#">1801(a)</a>	Initial	Operators Qualified Person	
Lead  Lead in Construction	<a href="#">5198(l)</a> <a href="#">1531.1(1)(1)(C)-(D)</a> <a href="#">1532.1(l)</a>	Initial Annual	Exposed Employees/ Supervisors Exposed Employees => Action Level	<a href="#">Lead in Construction (Fact Sheet)</a>
Lift Slab Construction	<a href="#">1722.1</a>		Competent Person	
Lockout/Blockout	<a href="#">3314</a> <a href="#">3314(j)</a>	Initial When Updated	Affected Employees Qualified Person	<a href="#">Lockout/Blockout</a>
Machinery & Equipment	<a href="#">1510(b)</a>	Before Use	Qualified Person	<a href="#">Lockout/Blockout</a>
Medical & Exposure Records - Access	<a href="#">3204(g)(1)</a>	Initial Annual	Affected Employees	Access to Medical and Exposure Records (poster) ( <a href="#">English</a> / <a href="#">Spanish</a> )
4,4-Methylenebis (2-Chloroaniline) MBOCA	<a href="#">5215(j)</a>	Initial Annual	Exposed Employees	
Methylene Chloride	<a href="#">5202(l)</a> <a href="#">5202 (Appendix A)</a>	Initial & As Necessary	Exposed Employees Qualified Person	
Methylenedianiline	<a href="#">5200(k)(3)</a> <a href="#">1535</a>	Initial Annual	Exposed Employees	
Miter Saws	<a href="#">4307.1(c)</a>	Initial	Operators	

**CALIFORNIA OSHA GENERAL TRAINING REQUIREMENTS**  
(REFERENCE [https://www.dir.ca.gov/dosh/dosh\\_publications/trainingreq.htm](https://www.dir.ca.gov/dosh/dosh_publications/trainingreq.htm))

Training Topic	T8 Section	Frequency of Training	Typical Job Classification	Cal/OSHA Publication
Noise Exposure	<a href="#">5099(a)</a>	Initial Annual	Employees Exposed => 85dBA TWA	
Openings/Holes - Floors & Roofs	<a href="#">3212(b)</a>		Qualified Person	
Personal Fall Arrest/Restraint Systems/	<a href="#">1670(b)(19)</a>		Competent Person	
Personal Protective Equipment	<a href="#">3380(c)</a>	Initial	PPE Users	
Pile Driving	<a href="#">1600</a>		Competent Person	
Portable Ladder	<a href="#">3276 (f)</a>	Before Use	User Employee Supervisor of User Employee	<a href="#">Portable Ladder Safety</a>
Calif. Posting Requirements	<a href="#">340</a>	Initial	All Employees	
Powder-Actuated Tools	<a href="#">1685(a)(1)</a> <a href="#">1689(a)</a>	Initial	Users Qualified Person	
Powered Platforms (Installed) for Building Maintenance	<a href="#">3298(a)</a> <a href="#">3296</a>	Initial	Assigned Employees Qualified Person	
Process Safety Management	<a href="#">5189(g)</a>	Initial Refresher & Supplemental Certification	Involved Employees	
Railroad - Signs & Signals	<a href="#">3333(d)</a>	Initial	Assigned Employees	
Reinforcing Steel/ Similar Projections	<a href="#">1712(f)(A)</a>		Qualified Person	
Respiratory Protection	<a href="#">5144(c) &amp; (k)</a> <a href="#">5144 Appendix A</a> <a href="#">5144 Appendix C</a>	Initial Annual	Users	<a href="#">Respiratory Protection in the Workplace</a>  <a href="#">Respiratory Protection (Fact Sheet)</a>
Roofing	<a href="#">1509(a)</a> <a href="#">1730(b)(8)-(9)</a>	Initial	Qualified Person	<a href="#">Roofing Safety (Tailgate Topic)</a>
Scaffolds	<a href="#">1637(k)(1)</a> <a href="#">1637</a> <a href="#">1658(g)</a>	Initial	Erectors & Dismantlers: Qualified Person	
Silica Dust: Power tool work on concrete or masonry materials	<a href="#">1530.1(e)(1)</a> <a href="#">1530.1(e)(2)</a>	Before Assignment	Assigned Employees Supervisor	<a href="#">Hazards of Silica in Construction eTool</a>
Supervisory Safety Training	<a href="#">3203(a)(7)(F)</a>	Initial Change	Supervisors	

**CALIFORNIA OSHA GENERAL TRAINING REQUIREMENTS**  
**(REFERENCE [https://www.dir.ca.gov/dosh/dosh\\_publications/trainingreq.htm](https://www.dir.ca.gov/dosh/dosh_publications/trainingreq.htm))**

<b>Training Topic</b>	<b>T8 Section</b>	<b>Frequency of Training</b>	<b>Typical Job Classification</b>	<b>Cal/OSHA Publication</b>
Traffic Control - Flaggers	<a href="#">1599(f) &amp;(g)</a>	Initial	Flaggers	
Tremolite (Non-Asbestos)	<a href="#">5208.1(n)</a>	Initial Annual	Exposed Employees	
Vinyl Chloride	<a href="#">5210(j)</a>	Initial Annual	Exposed Employees	
Welding & Cutting Safety - Hot Work	<a href="#">4799</a> <a href="#">4848(a)</a> <a href="#">1537(a)</a>	Initial	Welders Fire Watchers Qualified Person	
Wheels or Rims - Servicing	<a href="#">3326(c)</a>	Initial	Service Personnel	<a href="#">Servicing Single, Split Rim &amp; Multi-Piece Rim Wheel (Tailgate Topic)</a>

Qualified Person - A qualified person is a person designated by the employer; and by reason of training, experience, or instruction has demonstrated the ability to perform safely all assigned duties; &, when required is properly licensed in accordance with federal, state, or local laws and regulations.

Examples: Mobile Crane & Tower Crane Operators 5006.1(a); Scaffold Erection & Dismantling Supervisors 1637(k)(1); Demolition 1736; Personal Fall Arrest System supervisors 1670(b)

Competent Person - A competent person is a person who is capable of identifying existing and predictable hazards in the surroundings or working conditions that are unsanitary, hazardous, or dangerous to employees. The competent person has the authority to impose prompt corrective measures to eliminate these hazards.

Examples: Excavation - Inspectors 1541; Fall Protection Plan implementers & supervisors 1671.1; Lift Slab Construction 1522.1



## **APPENDIX T**

### **U.S. DHHS, CDC, NIOSH Recommendations for an Occupational Standard for Workers Exposed to Heat and Hot Environments**

### 1.2.2 Preplacement Medical Evaluations

For the purposes of the preplacement medical evaluation, all workers should be considered to be unacclimatized to hot environments. At a minimum, the preplacement medical evaluation of each prospective worker for a hot job should include the following elements:

- (1) A comprehensive work and medical history. The medical history should include a comprehensive review of all body systems as would be standard for a preplacement physical examination, along with specific questions regarding previous episodes of diagnosed heat-related illness, rhabdomyolysis, and questions aimed at determining acclimatization to the new employment environment.
- (2) A comprehensive physical examination should be conducted. At the discretion of the responsible healthcare provider, candidates who anticipate increased stress of physical activity of the job in a hot environment, those over 50 years of age or those younger than 50 years of age with underlying cardiac risk factors may need to have additional testing (e.g., electrocardiogram (ECG) with interpretation by a cardiologist).
- (3) An assessment of the use of therapeutic drugs, over-the-counter medications, supplements, alcohol, or caffeine that may increase the risk of heat injury or illness (see Chapter 7).
- (4) An assessment of obesity, defined as a body mass index (BMI)  $\geq 30$ . Measure height and weight to calculate body mass index according to the following formula:
 
$$\text{BMI} = \text{weight (in pounds)} \times 703 / [\text{height (in inches)}]^2$$
- (5) An assessment of the worker's ability to wear and use any protective clothing and

equipment, especially respirators, that is or may be required to be worn or used.

- (6) Other factors and examination details included in 7.3.1.1 Preplacement Physical Examination.

### 1.2.3 Periodic Medical Evaluations

Periodic medical evaluations should be made available at least annually to all workers who may be exposed at the worksite to heat stress exceeding the RAL. At minimum, the employer should provide the evaluations specified above. If circumstances warrant (e.g., an increase in job-related heat stress or changes in health status), the medical evaluation should be offered at more frequent intervals at the discretion of the responsible healthcare provider.

### 1.2.4 Emergency Medical Care

If the worker develops signs or symptoms of heat stroke or heat exhaustion, the employer should provide immediate emergency medical treatment (e.g., call 911 and cool down the worker). Other non-life-threatening heat-related illnesses may be treated with appropriate first aid procedures (see Table 4-3).

### 1.2.5 Information to Be Provided to the Responsible Healthcare Provider

The employer should provide the following information to the responsible healthcare provider performing or responsible for the medical monitoring program:

- (1) A copy of this recommended standard.
- (2) A description of the affected worker's duties and activities (e.g., shift schedules, work locations) as they relate to the worker's environmental and metabolic heat exposure.
- (3) An estimate of the worker's potential exposure to workplace heat (both environmental

## **APPENDIX U**

### **TCS Assembly Point Map**

1 2 3 4 5 6 7 8 9 10

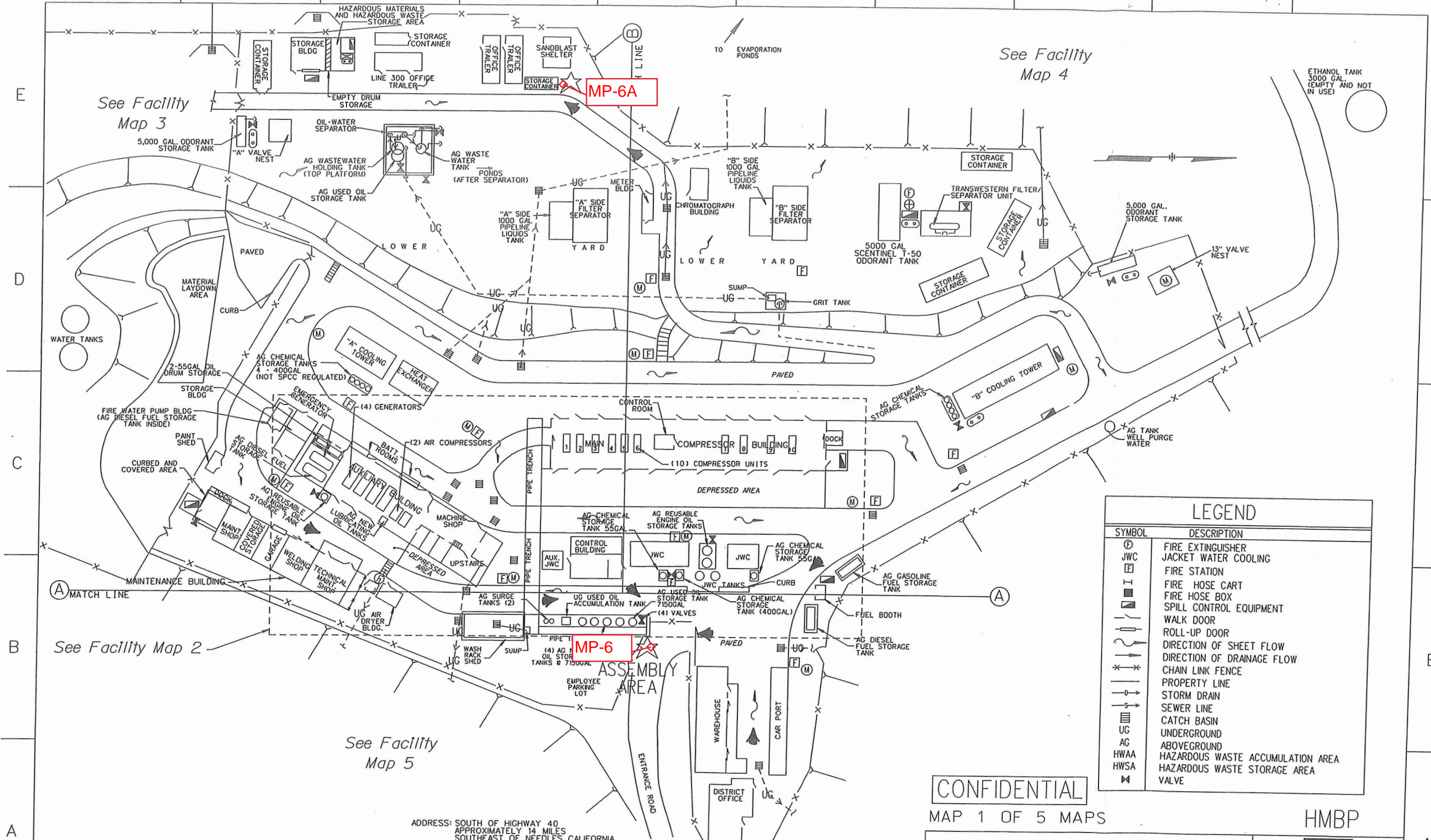

LEGEND	
SYMBOL	DESCRIPTION
(G)	FIRE EXTINGUISHER
JWC	JACKET WATER COOLING
(F)	FIRE STATION
(H)	FIRE HOSE CART
(B)	FIRE HOSE BOX
(S)	SPILL CONTROL EQUIPMENT
(W)	WALK DOOR
(R)	ROLL-UP DOOR
(D)	DIRECTION OF SHEET FLOW
(D')	DIRECTION OF DRAINAGE FLOW
(X)	CHAIN LINK FENCE
(P)	PROPERTY LINE
(SD)	STORM DRAIN
(SL)	SEWER LINE
(CB)	CATCH BASIN
UG	UNDERGROUND
AG	ABOVEGROUND
HWAA	HAZARDOUS WASTE ACCUMULATION AREA
HWSA	HAZARDOUS WASTE STORAGE AREA
(V)	VALVE

**CONFIDENTIAL**

MAP 1 OF 5 MAPS

FACILITY LAYOUT  
 TOPOCK  
 COMPRESSOR STATION  
 PACIFIC GAS AND ELECTRIC COMPANY  
 SAN FRANCISCO, CALIFORNIA

HMBP



ATTACHMENT 1  
 (FIGURE 2.1)

NO.	DATE	DESCRIPTION	APPRO.	NO.	DATE	DESCRIPTION	APPRO.	NO.	DATE	DESCRIPTION	APPRO.
6	12-02	Updated for HMBP		12	11-09	Updated for HMBP		18	8-12	Updated for HMBP (Parsons)	
5	2-02	Updated for HMBP		11	8-08	Updated for Interim		17	6-12	Updated for HMBP (Parsons)	
4	2-01	Updated for HMBP		10	1-08	Updated for HMBP		16	01-12	Updated for HMBP (Parsons)	
3	8-15	UPDATED FOR HMBP (PARSONS)		9	2-07	Updated for HMBP		15	02-11	Updated for SPCC Plan (ETIC)	
2	1-14	Updated for HMBP (Parsons)		8	2-04	Updated for HMBP		14	01-11	Updated for HMBP (Parsons)	
1	11-12	UPDATED FOR HMBP (PARSONS)		7	2-03	Updated for HMBP		13	1-10	Updated for HMBP (Parsons)	

topock2.env

F4347

1 2 3 4 5 6 7 8 9 10

**APPENDIX U**  
**PG&E Contractor Handbook**





ENTERPRISE CONTRACTOR SAFETY

---

# PG&E Contractor Handbook



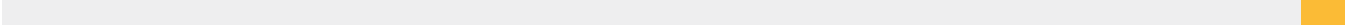

TABLE OF  
**CONTENTS**

**01\_INTRODUCTION**

01\_PG&E PURPOSE

02\_KEYS TO LIFE

03\_SIF CAPACITY & LEARNING MODEL

04\_HANDBOOK PURPOSE

05\_CONTRACTOR SAFETY STANDARD

06\_PG&E CONTACTS & RESOURCES

**02\_EXPECTATIONS & COMPLIANCE REQs**

01\_AUDIENCE

02\_PREQUALIFICATION & ISNETWORLD

03\_VARIANCE PROCEDURE

04\_MANAGEMENT ORGANIZATIONS  
ASSESSMENTS (MOAs)

05\_SUBCONTRACTOR MANAGEMENT

03\_CSQARs



TABLE OF  
**CONTENTS**

**03\_ SAFETY EXPECTATIONS**

01\_ GENERAL SAFETY EXPECTATIONS

02\_ CONTRACTOR OVERSIGHT REQs

03\_ START & STOP WORK AUTHORITY &  
RESPONSIBILITY

04\_ INCIDENT MANAGEMENT

05\_ SERIOUS INCIDENTS & FATALITIES/  
OPTION 1

05\_ SAFETY STANDDOWNS & PROBATION

06\_ SAFETY PLANS

**04\_ TRAINING & COMPETENCY  
EXPECTATIONS**

01\_ TRAINING REQUIREMENTS

02\_ OPERATOR QUALIFICATIONS

03\_ CONTRACTOR-LED TRAININGS

05\_PG&E SAFETY STANDARDS FOR ALL CONTRACTORS

01\_WILDFIRE SAFETY

02\_DRIVING SAFETY

03\_EXCAVATION SAFETY

03\_CORE

TABLE OF  
**CONTENTS**



# TABLE OF CONTENTS

07\_FUNCTIONAL AREA SPECIFIC  
EXPECTATIONS

01\_ELECTRIC OPERATIONS

02\_GAS OPERATIONS

03\_VEGETATION MANAGEMENT

04\_POWER GENERATION

05\_ENVIRONMENTAL REMEDIATION

06\_ENVIRONMENTAL MANAGEMENT

07\_ATS - APPLIED TECHNOLOGY SERVICES

08\_AVIATION SERVICES

09\_CRESS - CORPORATE REAL ESTATE  
STRATEGIC & SHARED SERVICES

10\_CUSTOMER CARE

11\_IT - INFORMATION TECHNOLOGY

12\_UPI - UTILITY PARTNERSHIPS &  
INNOVATIONS

08\_DEFINITIONS

# PG&E PURPOSE

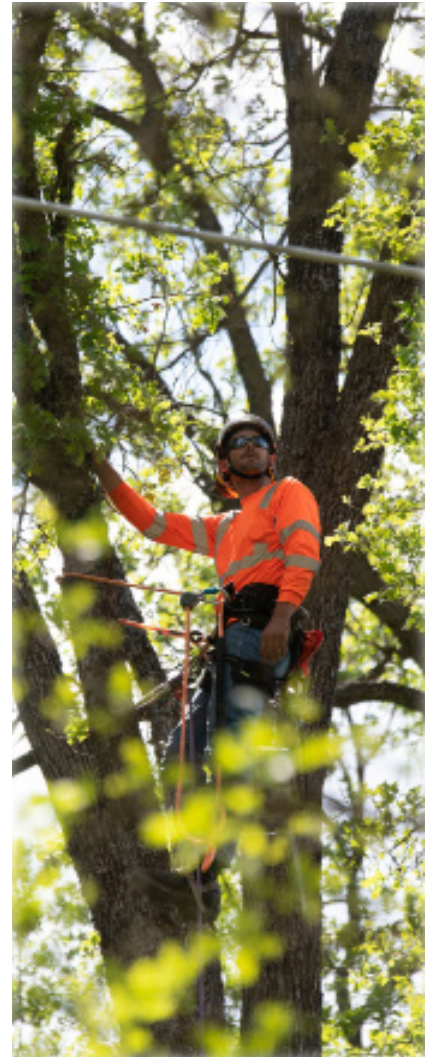

At Pacific Gas & Electric Company (PG&E), we are committed to our stands that everyone and everything is always safe and that catastrophic wildfires shall stop.

*We are all committed to protecting the health and safety of our coworkers, contractors, and the hometowns we serve while fostering a proactive and engaging safety culture.*

# KEYS TO LIFE

PG&E created the Keys to Life to expand on the goal that “Everyone and Everything is Always Safe.” It is a clear and direct commitment to encourage every PG&E partner, including contractors, to “Speak Up, Listen Up, and Follow Up.”

The following Keys to Life are pivotal, unwavering commitments to working safely. They align with PG&E’s virtues to be Trustworthy, Empathetic, Courageous, Tenacious, Nimble, and Owners of our individual and community’s safety.



1

**Conduct pre-job safety briefings prior to performing work activities.**



2

**Follow safe driving principles and equipment operating procedures.**



3

**Use personal protective equipment (PPE) for the task.**



4

**Follow electrical safety testing and grounding rules.**



5

**Follow clearance and energy lockout/tagout rules.**



6

**Follow confined space rules.**



7

**Follow suspended load rules.**



8

**Follow safety at heights rules.**



9

**Follow excavation procedures.**



10

**Follow hazardous environment procedures.**



# SIF CAPACITY & LEARNING MODEL

PG&E uses the SIF Capacity & Learning Model in our approach to Safety.

This approach has four key elements:

## □ STKY - STUFF THAT KILLS YOU

The focus is specifically identifying the mitigating risk exposure to hazards that can seriously injure or kill people.

## □ ENERGY WHEEL

As shown in Figure 1, this is a hazard-identification tool that must be used to identify the presence of high energy hazards before and during work. Incidents with more than 500 foot-pounds (ft-lb) of energy are more likely to be a SIF than not. Therefore, the term 'high-energy' refers to a condition where the physical energy exceeds 500 ft-lb, which corresponds to a condition where the most likely outcome of an incident is a SIF.

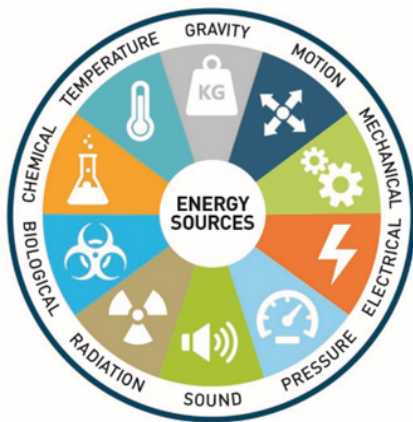

FIGURE 1: PG&E Energy Wheel

For more information or training on the SIF Capacity & Learning Model, please reach out to your PG&E Project Leads.

## □ OPERATIONAL LEARNING

An approach to learning and improving which examines both successful operations and failure. Operational learning relies on frontline workers explaining how work is performed. Organizations which actively seek opportunities to learn are successful in enhancing their performance while creating the capacity to fail safely.

## □ DIRECT CONTROLS

Once the high energy hazard is identified, it must be appropriately controlled through the use of preventative and/or mitigative controls. Direct controls provide the highest level of safety and must be implemented whenever possible. A direct control is one that is specifically targeted to the high-energy source; effectively mitigates exposure to the high-energy source when installed, verified, and used properly (i.e., a SIF reasonably should not occur if these conditions are present); and is effective even if there is unintentional human error during the work (unrelated to the installation of the control).

Examples of direct controls include LOTO, machine guarding, hard physical barriers, fall protection, and cover-up. Examples that are NOT direct controls include training, warning signs, rules, and experience because they are susceptible to unintentional human error.



# HANDBOOK PURPOSE



This Handbook is designed to provide PG&E Contractors with additional resources to safely perform work in partnership with PG&E.

The contents of this Handbook are not meant to supersede established work procedures or guidelines outlined by local, state, or federal regulations (such as OSHA work standards and procedures).

Instead, this Handbook offers additional resources to contractors where PG&E's requirements and expectations exceed or differ from standard procedures.

The purpose of this Handbook is as follows:

- Outline general safety and compliance guidelines for PG&E contractors to comply with local, state, federal, and PG&E specific requirements.
- Provide additional contacts and resources for contractors to escalate questions and concerns.
- Define PG&E's Contractor Safety Program Contract Requirements for new and existing contractors.
- Encourage safe work practices towards the goal that "Everyone and Everything is Always Safe."
- Define compliance requirements where PG&E standards and requirements exceed individual contractor requirements, including Functional Area-specific expectations. (Future revisions of this Handbook)

Notice: This document is uncontrolled when downloaded. Verify downloaded document aligns with the online document.

# THE STANDARD

At PG&E, nothing is more important than public, employee, and contractor safety. In support of this commitment, PG&E has established an Enterprise Contractor Safety Program. This program outlines the minimum requirements for managing and overseeing contractors and subcontractors (at any tier) that perform medium and high-risk work activities on behalf of PG&E, on either PG&E or customer sites and assets.



The contents of this Handbook describe the Contractor's responsibilities as outlined in PG&E's SAFE-3001S Contractor Safety Standard.

## PG&E CONTACTS & RESOURCES

Enterprise Contractor Safety Team  
ContractorSafetyInfo@pge.com

PG&E Training Questions  
ContractorSafetyISNTraining@pge.com

ISNetwork Customer Support  
1-800-976-1303



# EXPECTATIONS & COMPLIANCE REQUIREMENTS



**While all contractors are expected to perform their work safely, PG&E's Contractor Safety Program applies to contractors performing work activities defined as medium or high-risk work per the PG&E Contractor Safety Risk Matrix.**

## Audience

Contractors must have the same or higher risk level as their subcontractor(s) (at any tier: such as prime, subcontractor to prime [Tier 1], sub to the sub [Tier 2], etc.) that are hired to perform work, and all medium and high-risk subcontractors are subject to this standard. Prime contractors are responsible for ensuring their medium and high-risk subcontractors follow all requirements outlined in this Handbook and the PG&E Contractor Safety Standard.

For the purpose of this Handbook, medium and high-risk prime and subcontractors are collectively referred to as "Contractors."

The following agencies, entities, or contractors are not subject to the Contractor Safety Standard requirements:

1. Individual Augmented or contingent staffing contract partners working under the direct supervision of PG&E.
2. Vendors, suppliers, manufacturers, professional services (e.g., engineering, design, etc.) contracted by PG&E to provide goods and services to PG&E where the work being performed is not on PG&E property or within PG&E's right of way and not related to the maintenance and construction of PG&E infrastructure.
  - a) Exception: When PG&E has been awarded work as a Prime Contractor, where as PG&E subcontracts work to other pre-qualified contractors.
3. Tribal entities that perform work as Native American Monitors for cultural resource management purposes.
4. Other utilities, governmental entities, and applicant installers (or their contract partners) that have the right under Commission decisions and rules, pursuant to tariffs, or under easement/license, franchise, service, or other agreements to perform work on PG&E facilities (joint pole/trench agreements, Work Requested by Others (WRO) projects, franchise/Community-Based Organization agreements).

Notice: PG&E's Contractor Safety Risk Matrix is available on the external Contractor Safety Page.

# SAFETY PREQUALIFICATION & ISNETWORLD

**Contractors must subscribe to and maintain a subscription with ISNetworld (ISN) as PG&E's Safety Prequalification Contracted Administrator.**

ISN accounts are required of all medium and high-risk contractors, including sole proprietors. Where OSHA statistics and forms are requested, these documents are required of Contractors regardless of company size. OSHA statistics and forms are also required of companies in OSHA partially-exempt, low hazard industries, if the company falls under any medium or high-risk activity identified by PG&E's Contractor Safety Risk Matrix.

PG&E's Prequalification Requirements, managed within a Contractor's ISN account, are as follows:

Prequalification Criteria		
Targets (Based on year-to-year performance)	Acceptable	Not Acceptable
Number of Fatalities within the last five years <b>**See Note**</b>	Zero Fatalities within five years	One or more fatalities within the last five years
EMR most recent year certificate	Equal to or less than 1.10	Greater than 1.10
Confirmed (Closed) OSHA Citations within the last three years	Zero Serious/Willful/Repeat Citations	Greater than zero Serious/Willful/Repeat Citations
TRIR within the last three years	Equal to or less than the BLS industry average for that selected NAICS code	Greater than the BLS industry average for that selected NAICS code
DART Rate within the last three years	Equal to or less than the BLS industry average for that selected NAICS code	Greater than the BLS industry average for that selected NAICS code
Additionally, contractors are required to submit for PG&E review: <ul style="list-style-type: none"> <li>• Their company written safety programs specific to the hazards associated with their Work Types (Scope of Work). Programs must meet all Federal and State OSHA requirements.</li> <li>• Fit for Duty (Drug and Alcohol) Written Program</li> <li>• Employee Disciplinary Written Program</li> <li>• Three (3) year history of Serious Safety Incidents (Life Altering/Life Threatening) affecting the public</li> </ul>		
Acronyms		
EMR	Experience Modifier Rate	
TRIR	Total Recordable Incident Rate	
DART	Days Away, Restricted, Transfer Duty	
OSHA	Occupational Safety and Health Administration	
BLS	Bureau of Labor Statistics	
NAICS	North American Industry Classification System	

Note: In addition to annual statistics from the previous 3 calendar years, Contractor ISN grades are also affected in real-time by recent Serious Injuries or Fatalities (SIFs). Contractors are required to accurately and timely update their ISN accounts whenever a Serious Injury or Fatality (SIF) incident occurs on a PG&E project. Contractors with a fatality and/or more than ONE non-fatal PG&E SIF for the current calendar year will receive an automatic grade drop and will require a variance to continue working with PG&E. SIF incident counts restart on January 1st each year for this metric.

Contractors, including all subcontractors, shall not start any work for which prequalification is required without first obtaining written approval from PG&E that Contractor has satisfied PG&E's Prequalification Requirements. Should a Contractor's ISN grade drop to an unacceptable grade at any time (C or F grade), the Contractor must remedy their grade within 30 calendar days. Failure to achieve an acceptable ISN grade (A or B) will result in an immediate Stop-Work at Day 31. No work may continue until the Contractor has restored their ISN grade and status.

For PG&E support in understanding the ISN Scorecard grading and requirements, or your individual ISN grade and qualification status, contact the PG&E Enterprise Contractor Safety Team at [ContractorSafetyInfo@pge.com](mailto:ContractorSafetyInfo@pge.com). For ISN technical support, such as creating an account, logging in, or technical issues with uploading documents, contact ISN at 1-800-976-1303.



# VARIANCE PROCEDURE

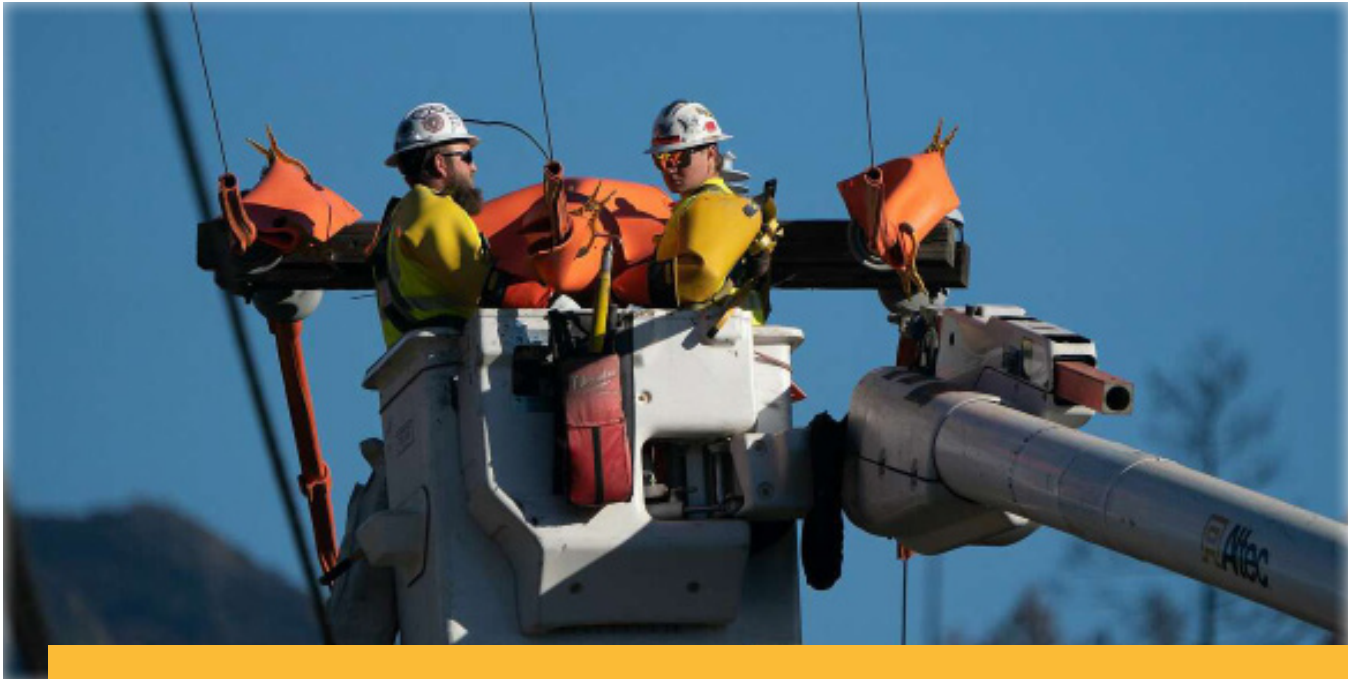

Contractors that are unable to meet the pre-qualification requirements outlined in this Handbook (such as not being able to achieve an A or B grade in ISN due to their SHE Statistics or Experience Modifier) are not considered pre-qualified for PG&E work.

However, if there are no other pre-qualified contractors available to perform the work, or the Contractor provides a unique service, the Contractor may be eligible for a Grade Variance.

Grade Variances require PG&E Chief Safety Officer Approval and detailed safety mitigation plans from the Contractor's responsible Functional Area. All Variance Requests must originate from the PG&E Project Lead responsible for the Contractor work in accordance with PG&E's Contractor Safety Prequalification Variance Request Procedure, SAFE-3001P-11.



# MANAGEMENT ORGANIZATIONS ASSESSMENTS (MOAs)

PG&E's Enterprise Contractor Safety Team may assign a **Management Organizational Assessment (MOA)** in ISN to Contractors to assess: the management staff for Contractor organizational structures, proposed spans of control, relevant work, Enterprise Health and Safety experience, employee training plans, and other relevant topics.

MOAs may be administered to PG&E Contractors who are new in business (less than three years), experience significant growth, or discretionally as identified by the Functional Area or Enterprise Contractor Safety Team.

If a MOA has been assigned, immediate action is required to prevent a grade impact.



# SUBCONTRACTOR MANAGEMENT

Contractors are responsible for maintaining the safety of all crew members, including Subcontractors at all tiers. A Prime Contractor is directly hired by PG&E to complete a specific scope of work or service. A first-tier contractor or subcontractor is directly hired by the prime contractor. A second-tier contractor is directly hired by the first tier, et cetera. All, but the prime contractor directly hired by PG&E, are subcontractors to PG&E.

While the entirety of this Handbook applies to Contractor and Subcontractor requirements, the following are specific Contractor expectations regarding Subcontractor Management.



**Prime Contractor Shall:**

1. Submit and maintain an updated Exhibit 1A form with their contract documents listing all low, medium, and high-risk Subcontractors expected to perform work on a project. Exhibit 1A forms shall list the subcontractor's name, evaluated risk level, ISN identification (if applicable), and verification of meeting PG&E's Prequalification Requirement.
2. Provide Subcontractors with PG&E's Contractor Safety Program requirements, outlined in this Handbook and the "Based on Utility Standard SAFE-3001S" contract document, and ensure Subcontractor compliance, including training all personnel on PG&E's Contractor Safety Program. For multi-tiered subcontracted work, the Prime contractor may leverage subcontractor companies to support in this task, where higher tiered subcontractors train their lower tier subcontractors, but the Prime contractor is ultimately responsible for ensuring that compliance is maintained.
3. Ensure all medium and high-risk Subcontractors have registered in ISN, are connected to the Prime Contractor via SubTracker and connected to PG&E, and regularly monitor that subcontractors maintain an A or B grade during all work activities.
  - ◇ If a subcontractor becomes unqualified while performing work for PG&E, the Prime Contractor shall notify PG&E immediately for evaluation and decision for work commencement.
4. Ensure no Subcontractor(s) have a risk level that exceeds the Prime Contractor or a Subcontractor of a higher tier.
5. Complete Subcontractor Safety Evaluations that cover a subcontractor's overall safety performance, including but not limited to:
  - ◇ Work site hazard mitigation
  - ◇ Training and qualifications compliance
  - ◇ Work site safety performance (observations)
  - ◇ Safety incident and injury prevention and reporting
  - ◇ Development and implementation of a PG&E approved safety plan
  - ◇ Speak Up and Stop Work Authority
  - ◇ Wildfire Prevention and Mitigation
  - ◇ Subcontractor evaluations must be completed annually, at minimum, and stored in a repository of the Prime Contractor's choice. Evaluations must be submitted when requested by PG&E Contractor Safety Teams.
6. Ensure Subcontractors are reporting all applicable incidents and data to PG&E via the ISN SiteTracker Tool and to their PG&E Representatives via the appropriate Incident Management Processes.



# CSQARs



**PG&E will facilitate Contractor Safety Quality Assurance Reviews (CSQARs) with selected Contractors with adverse trends in safety performance and who are at risk of experiencing a Serious Injury or Fatality (SIF).**

A CSQAR is a detailed assessment of the Contractor's safety program implementation and field safety performance. The process includes a desktop review, safety culture survey, barrier analysis, and leadership engagement with a focus on the elimination of serious injuries and fatalities.

Safety concerns or issues identified must be documented and communicated to the Contractor and the PG&E Representative and a safety improvement plan for compliance and mitigation must be established by the contractor.

Once PG&E accepts the safety improvement plan, PG&E and the Contractor will participate in a documented Effectiveness Review to validate implementation and effectiveness of the safety improvement plan.

The goal of every CSQAR is to eliminate serious injuries and fatalities.

# SAFETY EXPECTATIONS

Every operational priority or service commitment can be met without compromising safety when proper direct controls are in place. No activity is so urgent or important that safety or health of our coworkers, contract partners, and the public is compromised. This Handbook section outlines general safety expectations for Contractors that are specific to PG&E.

## GENERAL SAFETY EXPECTATIONS

Contractors must follow all applicable local, state, and federal laws, including PG&E and regulatory requirements and control measures to eliminate or mitigate scope specific hazards.

Site safety controls are required at work sites to ensure that all persons, including visitors, contractors, subcontractors, PG&E employees, and members of the public are informed of the hazards and controls required for the work location. All tasks, hazards, and mitigations shall be noted on the Contractor's Safety Plan (see Section 3.6).

All Contractors performing work on behalf of PG&E or on customer sites and assets must be fit for duty and comply with the Contractor's approved Drug & Alcohol Written Safety Program, as outlined in PG&E's Drug & Alcohol Abuse and Testing Policies. An approved Non-DOT Drug & Alcohol Policy is required for all Contractors and is stored in ISN.

Contractors must inspect all materials, tools, equipment, and facilities for safety prior to performing any work. They are required to provide and ensure that workers use Personal Protective Equipment (PPE) as required by Cal/OSHA (California Code of Regulations [CCR], Title 8, Section 3380) regulatory requirements to perform their work activities safely and when defined in their safety plan, hazard analysis, or when required to access a specific PG&E location.



# CONTRACTOR OVERSIGHT EXPECTATIONS

## CONTRACTOR OVERSIGHT REQUIREMENTS

Contractors are responsible for maintaining effective oversight of their work crews, including subcontractors at geographically remote locations. PG&E requires that Contractors perform documented safety observations, at a minimum of one observation a week for each project or crew performing high risk work, to ensure compliance with PG&E and regulatory safety requirements for their personnel and sub-tier workforces under their direct control. Contractors may use documentation platforms as they deem appropriate, and must provide observations within 48 hours upon request.



Contractor Oversight includes the following Contractor responsibilities:

- Appropriately identify, analyze, and communicate known or potential hazards to their personnel and Subcontractors, other potentially impacted workforces, and the public (when present), prior to commencing work.
- Ensure that contractors, at any tier, used for the work are provided appropriate levels of safety oversight. This includes when their sub-tier work is geographically remote from that of the Prime Contractor.
- Ensure all identified safety deficiencies are corrected and properly tracked to closure in a timely manner.
- Ensure all safety incidents, including Serious Safety Incidents and Serious Injury and Fatality (SIF) Incidents are reported to PG&E immediately.

# START & STOP WORK AUTHORITY & RESPONSIBILITY

Based on the SAFE-02 PG&E Safe Start & Stop Work Policy, all PG&E Contractors possess Start Work Authority, defined as the commitment to not start work until it is safe to do so. This entails that the work has been assessed for the hazards present, high energy hazards have been identified and assigned direct controls, and a thorough Pre-Job Briefing or Tail-board has been conducted with all parties.

All PG&E Contractors also possess Stop Work Authority and Stop Work Responsibility. Any Contractor employee is authorized and empowered to stop work at any time to prevent injury, harm, or damage to PG&E coworkers, contractors, visitors, vendors, the public, property and equipment, or the environment.

The contractor shall safely stop the work, equipment, or process and gather all personnel in the area to help identify the safety issue(s).

The contractor shall contact the person in charge or supervisor/manager to inform them that work has been stopped and resolution of an immediate safety concern is necessary.

The person in charge or supervisor/manager shall discuss the problem(s) and develop an appropriate resolution for the safety issues.

Unsafe conditions and at-risk behaviors shall be corrected prior to proceeding with work. Do not proceed in the face of uncertain safety or job conditions.

If there is a disagreement or reservations about the resolution, then the next level of management shall be contacted along with the PG&E Regional/Functional Area Safety Director. Together the group will work out a feasible solution that can be performed safely and is consistent with PG&E policies, programs, or safety manuals.

After the issue has been evaluated and determination made by qualified experts that the safety issue has been properly resolved and all parties are confident that the conditions for work are safe, the work can resume. Be sure to capture and share learnings as a near miss/good catch and submit accordingly.



# INCIDENT MANAGEMENT

The timely reporting of safety incidents enables PG&E and Contractors to partner and identify potential trends of concern, prevent future safety incidents, and share Lessons Learned to improve overall safety culture. In accordance with SAFE-3001S Enterprise Contractor Safety Management Standard, all Contractor and Subcontractor related serious safety incidents or Serious Injury and Fatalities (SIFs) must be immediately reported to the Contractor's Functional Area (FA) Project Manager/Job Sponsor/Representative.

This includes:

- *Contractor fatality, serious injury or illness, inpatient hospitalization, permanent disfigurement, loss of any bodily member, electrical contact or flash requiring medical attention, systemic incident, serious concealed danger, or use of emergency services.*



Contractors are responsible for reporting and investigating all safety incidents that occur during the Contractor's PG&E related work. Incident investigations should be collaborative, and Contractors should request assistance from PG&E where appropriate. When requested, the Contractor will supply PG&E with complete copies of all documents, photographs, witness statements, and other evidence related to the incident.

Each PG&E Functional Area has developed additional incident reporting requirements. Before work begins, Contractors are required to coordinate with their PG&E project leads and understand the reporting process for their scope, including the types of incidents to be reported and how to report them. Additional incident types that may be requested include OSHA Recordables, Days Away/Restricted/Transferred (DARTs), Lost Workdays (LWDs), First Aids, Line Strikes and Dig Ins, Near Misses, and Motor Vehicle Incidents.

Prime Contractors are responsible for reporting their Subcontractor's incidents to the appropriate PG&E Functional Areas. However, Subcontractors must report their incidents directly in their ISN SiteTracker monthly reports.

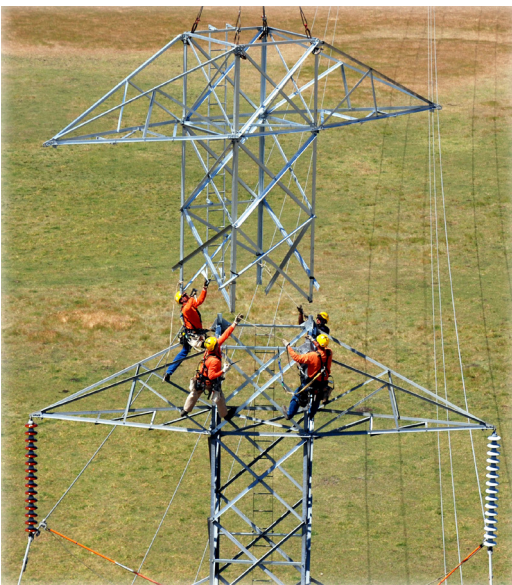

Where we act safely, and avoid potential incidents, can provide just as much information as when incidents do occur. Contractors are encouraged to share their company's Best Practices, Near Misses, Good Catches, and Lessons Learned with their PG&E Project Teams and Functional Areas. These present an opportunity to share our successes as PG&E partners and promote our safety culture.

# SERIOUS INCIDENTS & FATALITIES/ OPTION 1

All PG&E serious safety incidents (SSIs) or Serious Injury and Fatalities (SIFs) must be reported to the Safety Incident Notification Line (Option 1). The PG&E Project Manager/Job Sponsor/Representative reports contractor related incidents or Serious Injury and Fatality (SIF-A/P) to the Safety Incident Notification (Option 1) on behalf of the affected Contractor.



## THE OBJECTIVES OF THE SAFETY INCIDENT NOTIFICATION LINE (OPTION 1) ARE AS FOLLOWS:

1

Establish a notification and response management standard to provide guidance for the timely, consistent, and appropriate level of notification and response to PG&E safety-related incidents.

2

Meet regulatory agency requirements and internal PG&E requirements for incident notification and response.

3

Meet all regulatory agencies requirements including but not limited to California Occupational Safety & Health Administration (Cal/OSHA), California Public Utilities Commission (CPUC), and Utility Standard: SAFE-1001S Injury and Illness Prevention Plan (IIPP).

4

Every employer shall report immediately any serious injury or death, of an employee occurring in a place of employment or relating to any employment by telephone to the nearest District Office of the Division of Occupational Safety and Health.

5

Immediately means as soon as practically possible but not longer than eight (8) hours after the employer knows or with diligent inquiry would have known of the death or serious injury. If the employer can demonstrate that exigent circumstances exist, the time frame for the report may be made no longer than 24 hours after the incident (California Code of Regulations, Title 8, section 342).

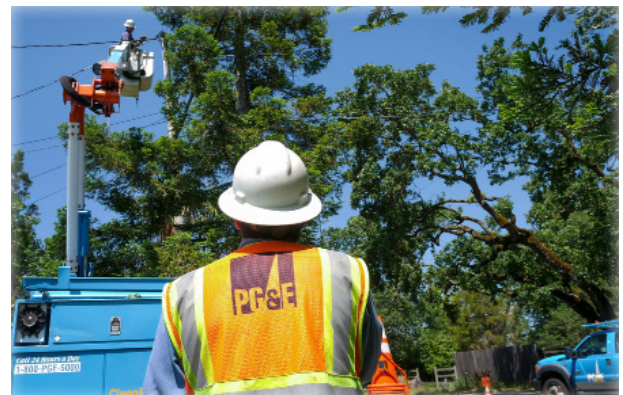





All serious safety incidents or SIFs for your company, including those that are not associated with PG&E projects, must also be uploaded to your ISNetwork account via SHE Statistics on an annual basis. Following the ISNetwork incident submittal, PG&E will assign an Action Item with a request for incident details. This allows PG&E to provide a documented, qualitative review of the incident and communicate the event to key stakeholders within PG&E. If there is actual or potential relevance for PG&E related work, a PG&E review committee will determine if the Contractor should be disqualified from consideration for future PG&E work, or if additional safety mitigations should be required.

Contractors are required to promptly, thoroughly, and transparently investigate all serious safety incidents and SIFs using causal analysis methodologies and develop and implement corrective actions. PG&E has developed an Enterprise Cause Evaluation Standard that may be referenced upon request for support in developing these investigations and corrective actions. All SIF Incidents occurring on a PG&E project, including actual and potential incidents (SIF-A and SIF-P), shall be investigated jointly with PG&E.



# SAFETY STANDDOWNS & PROBATION



**The Enterprise Contractor Safety Stand Down and Probation Procedure (SAFE-3001P-24) provides a coordinated approach for PG&E Functional Areas to safely pause work when significant safety concerns or trends are present.**

**PG&E field personnel will provide information regarding a safety event or identified issue(s) of concern to their Leadership.**

After additional information is collected, such as incident details or observation data, Leadership will coordinate with PG&E and Contractor parties to determine if a Stand Down is needed and provide a Contractor Safety Stand Down Notice.

A Stand Down or Probation may be administered for a single job/project/worksite. However, if the scope of the Stand Down has the potential to impact system-wide construction activities or various work types and projects, PG&E may initiate an Enterprise-wide Stand Down for all PG&E work.



Contractors are responsible for communicating with the PG&E Safety Action Assessment Committee (SAAC) assigned to the Stand Down or Probation (or other PG&E teams), and develop and implement a PG&E accepted Safety Improvement Plan before any work may resume. Comprehensive Safety Improvement Plans include:

- Problem Statement(s) and Containment Plan (developed within 48 hours unless otherwise noted)
- Barrier Analysis for each problem identified
- Identification of causes, additional findings, and mitigating actions (i.e. countermeasures, corrective and preventive actions)

**Alternative Safety Improvement Plan methodologies may be approved by PG&E and used as applicable based on the safety incident.**

Contractors will receive guidance from PG&E partners if a Stand Down or Probation is applicable, as well as templates and support in creating the Safety Improvement Plan. Monthly check-ins will occur to review implementation and effectiveness of Safety Improvement Plans, and updates should be made as needed.

# SAFETY PLANS



## SAFETY PLAN ACCESS

All contractor personnel shall have access to their Safety Plan for reference during work activities. Any deviation from the Safety Plan or hazard control methods shall be reviewed and approved by the responsible PG&E personnel or designee. All Contractors are required to provide training to their personnel and Subcontractors on the approved Safety Plan.



## GUIDE FOR SAFETY PLANS

SAFE-3001P-20-JA04, Enterprise Contractor Safety Plan Job Aid, gives detailed information on the intent, creation, and retention of Safety Plans. A Safety Plan template and JHA template that establishes the minimum PG&E Safety Plan requirements are available on the PG&E Enterprise Contractor Safety Page.

Contractor Safety Plans are comprehensive reference documents for personnel in the field to perform work safely.

They should cover the entire scope of work for the specific project or program and include work scopes performed by both prime and subcontractor partners.

Developing these safety plans in advance of work allows PG&E to verify that contractor partners have identified and mitigated safety concerns and meet all applicable regulatory requirements.

Safety Plans include comprehensive scopes of work, and the tasks, hazards, proper mitigation measures, and training

needed to safely perform the identified work.

All contractors must provide a PG&E approved safety plan and Job Hazard Analysis for high-risk work that fully addresses the scope-specific work to be performed.

Some Functional Areas may also request Safety Plans for medium-risk work.

There are three main categories of safety documents identified by PG&E. Some companies may use these terms interchangeably or have different terms for these documents.

Regardless of naming conventions, each aspect must be present in your company's safety documents.



## Job Hazard Analysis (JHAs)

JHAs, Job Safety Analyses (JSAs), Job Site Safety Analyses (JSSAs), or similarly named documents are task specific and an integral part of an overall Safety Plan. JHAs describe, in detail, the task at hand, the hazards associated with the task, and the mitigations and trainings associated with the task. JHAs should also include site-specific information, or any changes to the task, method, or condition while performing the scope of work.

- a. All Prime and Subcontractors must complete a daily Job Hazard Analysis prior to the beginning of work activities.

## Pre-Job Safety Briefings or Tailboards

Pre-Job Safety Briefings are the application of the Safety Plan and JHA. These daily meetings should be led by competent PG&E or Contractor representatives and communicate all daily tasks, hazards, and mitigations. Pre-Job Safety Briefings are required for medium and high-risk work.

- a. Prime and Subcontractors onsite shall jointly participate in daily Pre-Job Safety Briefings.
- b. If conditions change during the course of the work, the Contractor shall pause work, conduct another tailboard, and revise the JHA as appropriate.

## Programmatic or Project-Specific Safety Plans

Programmatic or Project Specific Safety Plans: Safety Plans should cover the entire scope of work to be performed on the project or program work. Safety Plans must include all anticipated tasks, hazards, mitigations, and appropriate training. Other Safety Plan content may include: PG&E and Contractor contacts, field leadership and safety observation plans, PPE requirements, Emergency Action Plans, Certifications and Licenses, Site Orientation, etc.

- a. Prime Contractor Safety Plans should include all Subcontractor work scopes. Subcontractors may sign onto their Prime Contractor's Safety Plan or create their own. A Safety Plan is required for all high-risk work for each program or project.

# TRAINING REQUIREMENTS

Contractor trainings are housed in ISN and are assigned to Contractor companies based on their Functional Area site connections and/or scopes of work. The Contractor company is then responsible for assigning trainings to individual employees.

All Contractor employees performing medium and high-risk work are required to complete the Corporate Contractor Safety Awareness Training course, SAFE-0101, in ISN. Failure to validate this training, or any other required training, may result in work being paused, and the employee being temporarily removed from site until the training can be verified in ISN.

Any onsite Contractor performing medium or high-risk work must be assigned and carry an ISN ID Badge. ISN Badges may be presented in digital form (such as using the ISN or Empower App) and are not required of low-risk employees (such as those providing office supported work types). Workers must always carry their ISN Badge while working for PG&E and display to PG&E upon request.

PG&E published the “PG&E Training in ISNworld - Contractor Training Safety Advisories” Bulletin Board post in ISN that links all Contractor trainings to their associated Safety Advisories. Contractors are responsible for reviewing the Safety Advisories for all assigned training, and determining if the audience matches the scope of their work. If a training does not apply to a Contractor’s scope of work, the training does not need to be completed, but it will remain in the Training Basket as a compliance item showing that PG&E made it available. Contractor Training Administrators are responsible for continuously maintaining accurate ISN Training Profiles, which may include updating ISN training statuses when trainings are taken in a group setting, marking employees as inactive, or removing employees that are no longer employed, etc.

ISN trainings can be completed on desktop accounts or via ISN’s Empower App. Most ISN trainings can also be administered in a group setting, and the Contractor’s ISN Account Administrator is responsible for manually assigning training credit to all employees in attendance.

Contractors with PG&E LAN IDs who complete training through the PG&E Academy that are also listed in ISN should request their Training Administrator to manually assign the appropriate training credit in ISN.







## OPERATOR QUALIFICATIONS

Federal and State regulation CFR 49.192, Subpart N and GO 112F require that individuals performing covered tasks on the gas pipeline system hold the applicable qualifications at the time of performing the work.

Operator Qualification is required for any work on the gas pipeline system or in construction of new gas pipeline facilities that will be connected to the gas pipeline system, regardless of the Functional Area that the Contractor is supporting.

Contractors are responsible for ensuring that their employees, and subcontractors, performing covered tasks are properly qualified during onboarding and throughout the duration of all work activities.

### CONTRACTOR-LED TRAININGS

Contractors are responsible for ensuring their employees and subcontractors are properly trained and qualified to perform work on behalf of PG&E in compliance with all applicable regulatory requirements. This includes, but is not limited to: PG&E's Contractor Safety Program, the Contractor's safety program, all job-related hazards and tasks, and applicable laws. Training materials and verification must be provided to PG&E within 48 hours upon request.



A full list of PG&E qualifications can be obtained by calling 1-855-854-6227, and selecting Option 4, or by emailing [OQPlasticSched@pge.com](mailto:OQPlasticSched@pge.com).



For more information, contractors can visit the Gas Pipeline Operator Qualification webpage.

# WILDFIRE SAFETY

One of PG&E's principal Stands is that "Catastrophic Wildfires Shall Stop." This stand will be supported and upheld by all Contract Partners.



In order to comply with PG&E expectations, and California Public Resource Code (PRC 4427, 4428, & 4431), a utility standard has been created: EMER-4102S (formally TD-1464S), "Preventing and Mitigating Fires While Performing PG&E Work." This standard and all its attachments can be found here: [www.pge.com/wildfireprevention](http://www.pge.com/wildfireprevention).

EMER-4102S establishes precautions for PG&E employees and contract partners to follow when traveling to, performing work, or operating outdoors on or near any forest-, brush-, or grass-covered land. It must be complied with 365 days out of the year. Additionally, the required SAFE-1503WBT, "Fire Danger Precautions" training must be completed no later than 90 days past the assignment date and then going forward annually between January 1 and April 1.

Whenever these forest, brush, or grass-covered land conditions exist, employees shall determine what Fire Index Area (FIA) they are working in, and evaluate the Fire Potential Index (FPI) for that day. Using this information, in combination with the standard, employees will determine what mitigations they will take when performing work on PG&E's behalf.

The mitigations vary based on the FPI as well as the type of work being conducted. Please refer to the Wildfire Mitigation Matrix for additional details.

Lastly, Contractors are responsible for completing and documenting the Wildfire Risk Assessment prior to any work starting.

# WILDFIRE PREVENTION

Due to climate and environmental issues in the state of California, wildfire is a significant threat needing attention for prevention and mitigation. Therefore, PG&E has revised procedural standards to best support addressing this urgent situation.

All suppliers working in the field are expected to adhere to these requirements taking responsibility for actions which could potentially cause wildfire. This includes awareness of wildfire risk in geographic areas where work is to be performed, properly outfitting vehicles and personnel with adequate training and tools; ensuring each individual is accountable for preventing and mitigating potential wildfire risk.



If ignition of any sort occurs, call emergency services (9-1-1) IMMEDIATELY, even if the fire has been suppressed.

Additionally, the jobsite supervisor must call the Hazards Awareness and Warning Center (HAWC) at 1-800-255-7593.

## Key Links

- [Preventing and Mitigating Fires While Performing PG&E Work \(PDF\)](#)
- [Attachment 1, Wildfire Mitigation Matrix \(PDF\)](#)
- [Attachment 2, Wildfire Risk Checklist \(PDF\)](#)
- [Reporting Ignitions on the Jobsite – English \(PDF\)](#)
- [Reporting Ignitions on the Jobsite – Spanish \(PDF\)](#)



# DRIVING SAFETY

Each medium- and high-risk contractor is required to prepare a Motor Vehicle Driving Safety (MVDS) program. Please coordinate with your own Contractor Leadership to view this document and familiarize yourself with company-specific expectations. stand will be supported and upheld by all Contract Partners.



To ensure your MVDS complies with PG&E expectations, refer to PG&E's Contractor Driving Safety Program Requirements.

Driving is one of the biggest risk exposures at PG&E. We are committed to all employees and contract partners driving safely when getting to the jobsite and returning home. To ensure all California State Laws are complied with at all times, PG&E highly recommends:

- Pre-trip inspection
- Journey Management Plan
- 360-walkaround prior to use

However, incidents do happen.

A Motor Vehicle Incident (MVI) is any event involving a PG&E employee or Contractor in an owned, leased, rented, or a personal vehicle being operated for PG&E business, which results in damage to any property or vehicles; injury to any employee, contractor, or 3rd party; or fatality to any employee, contractor, or 3rd party.

Any incident fitting this criteria must be submitted to Functional Area (FA) teams as soon as possible (within 8 hours of the MVI occurring). The FA team will follow up with your company to obtain any additional information required.

# PHONE-FREE POLICY

**Starting January 1, 2024, Contract Partners will be expected to comply with the updated Phone-Free requirements outlined below.**

## Prohibited Uses of Cell Phones, Hand-Held, and Hands-Free/Bluetooth® Devices

1. California law prohibits the writing, sending, or reading of text-based communications (email, text messages, instant messages, GPS) while driving a motor vehicle.
2. While California law allows drivers 18 years and older to use hands-free phones while driving, PG&E employees and contract partners are prohibited from using hands-free phones, including Bluetooth® Devices (Smart Watch, etc.) or other wired earpieces while driving on PG&E Business. Specifically, all employees may NOT use Cellular phones or other Bluetooth® Devices while driving to:
  - Cellular Phones, Hand-Held, and Hands-Free/Bluetooth® Devices may be used while safely and legally parked.
  - Cellular Phones may be used as a GPS, provided the course is set before the trip or departure from the vehicle's parked location. Any changes that require physical interaction with the device will only be conducted after being safely and legally parked in the vehicle.
  - All Cellular Phones or electronic wireless communication devices used for GPS must be mounted and secured in accordance with applicable state laws. (See California Vehicle Code section 23123.5 and 26708.)

## Permissible Uses of Cell Phones, Hand-Held, and Hands-Free/Bluetooth® Devices

1. Emergencies: In the event of an emergency, employees may use a Cellular Phone and/or Bluetooth® Device while the vehicle is in motion to make an emergency call to a law enforcement agency, a medical provider, the fire department, or other emergency service provider agencies.
  - Two-way radios installed in personally owned, contractor-owned, or leased vehicles may be used while driving by employees whose job duties require them. Conversations should be limited to dispatch purposes and emergency response activities.
  - Two-way radios shall not be used for direct dialing another user.
  - Two-way radios are permissible on group talk frequencies.



# EXCAVATION SAFETY

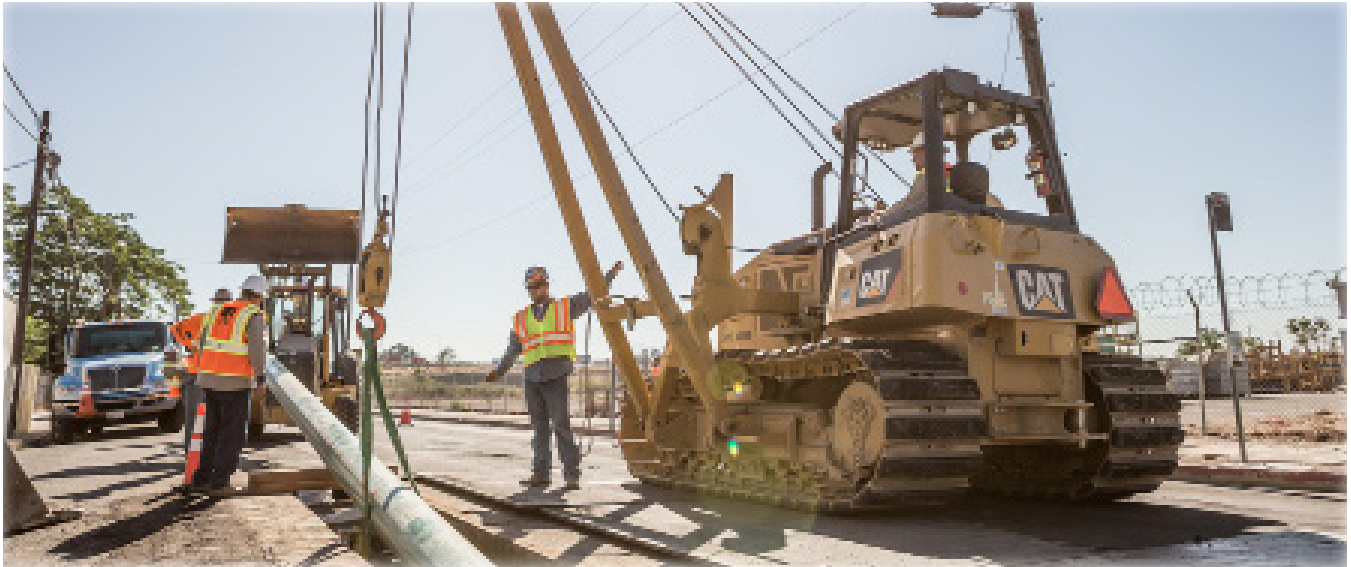

**Excavation activities are an integral part of PG&E projects for many Contractors across PG&E, supporting Gas, Electric, and other Functional Areas.**

In addition to presenting significant property damages and losses, excavation incidents have the potential to lead to injuries and even fatalities. For this reason, following safe excavation safety procedures are one of PG&E's 10 Keys to Life, and PG&E Leadership actively tracks over 30 Excavation Safety Metrics. Damages caused by dig-ins to PG&E facilities are 100% preventable with the proper mitigations and procedures.

PG&E's Damage Prevention Department is comprised of Locate & Mark (L&M), the Dig-in Reduction Team (DiRT), Aerial & Ground Patrol, Standby Governance, Damage Recovery and Metrics, and Public Awareness Teams with the express purpose of supporting the public and contractors to safely excavate around PG&E assets.

For additional support and resources for digging safely, visit the Resources for Safe Digging page or the Team at [DamagePrevention@pge.com](mailto:DamagePrevention@pge.com).

# CORE

PG&E's CORE OpenText Application allows Contractors secure, remote access to select documents in PGE's Technical Information Library. CORE stores standards and procedures that apply to both internal and contractor personnel, and is updated immediately as documents are revised.

Contractor partners should work with their PG&E project leads to determine which PG&E standards and procedures apply to their scope of work prior to any work being performed. For documents not stored in CORE, PG&E project leads will share as needed.

To request access to PG&E's CORE, reach out to your PG&E Project Lead and assign an account administrator for your company. Your PG&E representative will connect your account administrator to the CORE Team. The account administrator is responsible for providing their company name, administrator name, email, and phone number. They will receive instructional emails from the CORE Team and can add and remove contractor employees after completing the account set-up.



# FUNCTIONAL AREA SPECIFICATIONS

Future revisions of this Handbook will include expectations specific to each Functional Area.

01	7.1 Electric Operations
02	7.2 Gas Operations
03	7.3 Vegetation Management
04	7.4 Power Generation
05	7.5 Environmental Remediation
06	7.6 Environmental Manage-
07	7.7 ATS - Applied Technology
08	7.8 Aviation Services
09	7.9 CRESS - Corporate Real Estate Strategic & Shared Services
10	7.10 Customer Care
11	7.11 IT - Information Technology
12	7.12 UPI - Utility Partnerships & Innovations

# DEFINITIONS

**Bluetooth® Device** - Smart technology wireless communications system intended to replace the cables connecting many types of devices, from mobile phones and headsets to hear monitors and medical equipment. Examples may include but are not limited to earpieces, headphones, car systems, smart watches, etc. Bluetooth devices are included under “Hands-Free Devices.”

**Cellular Phone** - A portable telephone that uses wireless cellular technology to send and receive phone signals.

**Contract Partner Safety Quality Assurance Review (CSQAR)** - A detailed assessment of the contract partner’s safety program implementation, safety culture and field safety performance. The process includes a desktop review, safety culture survey, barrier analysis and leadership engagement.

**Contractor or Contract Partner** - Company directly hired by PG&E to complete a specific SOW or service. This term also applies to all subcontract partners, at any tier, which have been retained by a primary PG&E contract partner to provide a service for PG&E related project work. Additionally, the term “subcontract partner” may include an individual, a group of workers (crew), equipment or other items used on a PG&E facility, project, or assets.

**CORE** - PG&E’s application that allows Contractors secure, remote access to select documents in PG&E’s Technical Information Library.

**Empower App** - ISN App that allows contractors to access work readiness information, their ISN ID, view compliance status, complete training, and read and acknowledge client documents and policies.

**Enterprise Contractor Safety (ECS)** - The team charged with overseeing the Enterprise Contractor Safety program and communicating the requirements to the FAs. ECS is found within the Enterprise Health and Safety department.

# DEFINITIONS

**Functional Area (Formerly Line of Business)** - PG&E has structured its diverse operations into Functional Areas, previously referred to as Lines of Business. These Functional Areas allow discrete, dedicated groups to provide support in the manner that best correlates to their operational needs. Functional Area examples include Gas Operations, Electric Distribution, Environmental Remediation, Vegetation Management, IT, and Hydro.

*Note: Functional Areas refer to the operation of the PG&E group that owns the work contract and may not directly correlate with the scope of work being performed by the contractor. For example, a contractor may be performing tree-trimming activities near a PG&E substation. Although the scope of work is "vegetation management" by definition of the work, the project is owned and managed by the Electric Substation Functional Area. Contractors who are unsure of their project's Functional Area should contact their PG&E Project or Program Lead, or their PG&E Contract Owner.*

**Functional Area (Formerly Line of Business)** - PG&E has structured its diverse operations into Functional Areas, previously referred to as Lines of Business. These Functional Areas allow discrete, dedicated groups to provide support in the manner that best correlates to their operational needs. Functional Area examples include Gas Operations, Electric Distribution, Environmental Remediation, Vegetation Management, IT, and Hydro.

**Hands-Free Devices** - The use of hands-free Covered Devices while driving a vehicle may be permitted by local law; however, it is prohibited by PG&E. Visual / Manual tasks performed on hands-free devices, including but not limited to dialing, typing, reading messages, setting up a wireless connection, programming a GPS, watching a video/DVD, and searching for a phone number or other information, are strictly prohibited while driving a vehicle, and must instead be accomplished when the vehicle is parked in a safe location.

**ISNetworld (ISN)** - PG&E's Safety Prequalification Contractor Administrator. A third-party company that evaluates Contractor safety performance and programs on behalf of PG&E.

**JHA (Job Hazard Analysis)** - May be referred to as Job Safety Analysis (JSA) or Jobsite Safety Analysis (JSSA). JHAs describe, in detail, the task at hand, the hazards associated with the task, and the mitigations and trainings associated with the task. Each task (or group of tasks) should have a separate JHA. JHAs should also include site-specific information, or any changes to the task, method, or condition while performing the scope of work.



# DEFINITIONS

**Keys to Life** – PG&E's ten commitments to the pursuit that “Everyone and Everything is Always Safe.” The first Key to Life is to “conduct pre-job safety briefings prior to performing work activities.”

**Management Organizational Assessment (MOA)** – Evaluations performed in ISN that assess the management staff for Contractor organizational structures, proposed spans of control, relevant work, Enterprise Health and Safety experience, employee training plans, and other relevant topics.

**Operator Qualifications** – Official qualifications required by federal and state regulations of all individuals performing covered tasks on the gas pipeline system. The Gas Pipeline Operator Qualification Webpage offers additional information and resources.

**Pre-Job Safety Briefing/Tailboard** - Application of the Safety Plan and JHAs and should distill and deliver the pertinent information to site personnel. These daily meetings should be led by competent PG&E or contractor personnel and are designed to communicate to the workforce the scope and responsibilities for the daily tasks.

**Prime Contract Partner** – Company directly hired by PG&E to complete a specific Scope of Work or service.

**Programmatic Safety Plan (PSP)** – Safety Plan that covers only programmatic work scopes. Must include the full program's scope of work, but does not require site-specific information such as the location of the nearest hospital, location of eye wash stations, etc.

**Programmatic Work** - A program (or programmatic work) refers to multiple projects, across multiple locations which are managed and delivered as a single package.

**Project Specific Safety Plan (PSSP)** – Safety plan that covers project work scopes. Formally referred to interchangeably with Site Specific Safety Plans (SSSPs). Must include the full project's scope of work and all site-specific information such as the location of the nearest hospital, location of eye wash stations, etc.

**Project Work** - A project refers to a specific, singular endeavor to deliver a tangible output. A project may be a stand-alone effort, or it may be part of an overarching program. At PG&E, a project is typically referred to as a 'job,' and work is typically performed at one location.



# DEFINITIONS

**Risk Level** – Classification given to contractors based on their highest risk work scope, as defined by the Enterprise Contractor Safety Risk Matrix.

**Safety Incident Notification Line (Option 1)** – Method for PG&E Representatives to report all Contractor Serious Injury and Fatalities (SIF-A/P).

**Safety Plan** – Detailed safety plan created to eliminate and/or mitigate specific job site environmental, health and safety hazards associated with the SOW. They should cover the entire scope of work for the specific project or program and include work scopes performed by both prime and subcontractor partners.

**SIF** – Serious Injury or Fatality. May be an actual event (SIF-A) or an event with the potential to result in a SIF (SIF-P). These include Contractor fatality, serious injury or illness, inpatient hospitalization, permanent disfigurement, loss of any bodily member, electrical contact or flash requiring medical attention, systemic incident, serious concealed danger, or use of emergency services.

**SIF Capacity & Learning Model** – PG&E's updated approach to Safety, which focuses on: STKY (Stuff That Kills You), the Energy Wheel, Direct Controls, and Operational Learning. Presentations and trainings on the SIF Capacity & Learning Model are available to Contractors upon request.

**Subcontractor** – Subcontract partners are contract partners that have been retained by a prime contract partner to provide services on behalf of PG&E.

**Tier** – A prime contractor is directly hired by PG&E to complete a specific SOW or service. A first-tier contractor is directly hired by the prime contractor. A second-tier contractor is directly hired by the first-tier contractor. A third-tier contractor is directly hired by the second-tier contractor, and so forth. All, but the prime contractor directly hired by PG&E, are subcontractors to PG&E.

**Variance (Grade Variance)** – Process that allows non prequalified contractors to perform PG&E work under specific guidelines. Variance requests must originate from PG&E representatives and are considered when there are no other prequalified contractors available to perform the work, or the Contractor provides a unique service.



## **APPENDIX W**

### **PG&E Journey Management and Trip Risk Assessment Guidance**

## PG&E Journey Management and Trip Risk Assessment Implementation

Please update your Safety Plan and driving hazard assessments (including JHA as applicable) to include Journey Management and Trip Risk Assessment. Please review attached safety advisory from Enterprise Contractor Safety (Journey Management and Trip Risk Assessments; March 13, 2023) for additional details.

Key components of a Journey Management Program include:

- A policy that contains site-specific assessments of transportation-related hazards and what steps will be taken to minimize these hazards **(e.g., documented hazard assessment; JHA)**
- A process to assess the need for trips and seek to eliminate unnecessary trips. If your coworkers are embarking on a high-risk journey<sup>1</sup>, ensure there is a proper approval workflow in place to evaluate the necessity of the trip. **(e.g., Meetings will be conducted virtually when possible. Scheduled fieldwork requires driving, therefore it is assumed that these trips are necessary.)**
- A procedure for managing trips, including safe route planning, and minimizing driving and environmental risk and the distances driven in a single trip. **(e.g., Routes will be planned to minimize potential driving hazards and maximize efficiency. Vehicle selection to be assessed per field project needs.)**
- A trip risk assessment<sup>2</sup> (TRA) must be used to prioritize and address route and scheduling management needs. (See TRA comment)

<sup>1</sup>High-risk Journey – **Includes, but not limited to: Vehicle or vehicle combination gross-vehicle weight of 10,001 pounds or more; towing; off-road or unmaintained roads; steep terrain; inclement weather; icy conditions; long duration (time and/or mileage) with the potential for fatigue.**

<sup>2</sup>**Trip Risk Assessment (TRA):**

- Trip Risk Assessments must be performed on the day of travel, with the goal of evaluating the immediate risks, by assessing weather and road conditions, cell phone or satellite device readiness, load security and hours the driver has been on duty.
- **Define and summarize your trip risk assessment process per PG&E's Trip Risk Assessment Guidance (currently defined in Journey Management and Trip Risk Assessments; March 13, 2023).**



# Safety Advisory

For leaders to discuss with their team



*Safety Advisory communications provide timely safety and health information related to hygiene equipment, tools, PPE, guidance documents and compliance.*

<b>Topic:</b>	Journey Management and Trip Risk Assessments
 <b>Relevant Key to Life:</b>	2. Follow safe driving principles and equipment operating procedures.
<b>Date:</b>	3/13/2023
<b>Audience:</b>	PG&E Contract Partners who Operate Motor Vehicles on Behalf of PG&E
<b>Key Messages:</b>	<p>Preventable motor vehicle rollovers continue to occur at a high rate among both PG&amp;E coworkers and its contract partners. As a combined PG&amp;E workforce, we experienced 20 motor vehicle rollover incidents in 2022, and already this year, we've had 5 incidents, including a contractor who lost their life in a vehicle rollover incident. This must stop!</p> <p><b>To eliminate rollovers, PG&amp;E now requires all contract partners to implement a Journey Management program that guides how a company manages transportation risk.</b></p> <p>Journey management refers to a planned and systematic process of reducing transportation-related risks within a company's operations. Foundational elements of the Journey Management Program include considerations for the need to travel and the safest mode of travel—something that can be applied in any industry and operating environment.</p> <p>The objective is to minimize unnecessary trips, distances driven, and the risks associated with necessary trips.</p> <p>Key components of a <b>Journey Management</b> Program include:</p> <ul style="list-style-type: none"> <li>• A policy that contains site-specific assessments of transportation-related hazards and what steps will be taken to minimize these hazards.</li> <li>• A process to assess the need for trips and seek to eliminate unnecessary trips. If your coworkers are embarking on a high-risk journey, ensure there is a proper approval workflow in place to evaluate the necessity of the trip.</li> <li>• A procedure for managing trips, including safe route planning, and minimizing driving and environmental risk and the distances driven in a single trip.</li> <li>• A trip risk assessment must be used to prioritize and address route and scheduling management needs.</li> </ul>
<b>Actions to Take:</b>	<p>All PG&amp;E contract partners who operate motor vehicles on behalf of PG&amp;E must develop and implement a Journey Management program.</p> <p>Trip Risk Assessments must be performed on the day of travel, with the goal of evaluating the immediate risks, by assessing weather and road conditions, cell phone or satellite device readiness, load security and hours the driver has been on duty.</p> <p>At a minimum, <b>Trip Risk Assessments</b> must validate the following:</p> <ol style="list-style-type: none"> <li>1. Current and expected weather conditions for planned travel</li> </ol>

	<ol style="list-style-type: none"> <li>2. Current road conditions for hazards, warnings, and requirements; consider using mobile applications such as Route4Trucks, inRoute (Intelligent Routing), or Trucker Path.</li> <li>3. Road layout and design (terrain, slope, road type, width, layout (tight curves), ditches, no or soft shoulder, drop offs)</li> <li>4. Selection of a primary and alternate back up route; do not prioritize based on speed or duration of travel and select the safest route for that situation</li> <li>5. Everyone traveling knows the destination address</li> <li>6. A travel plan is in place; if traveling with a crew, include space between trucks, communication plan, resting/ break locations, and destination parking plan</li> <li>7. Identification of community hazards (high traffic areas, low bridges, community threats/concerns)</li> <li>8. Vehicle and load dimensions to ensure they are adequate for purposed route</li> <li>9. A safe path of travel from location, looking for hazards in path, above, to the sides, and below</li> <li>10. Everyone knows the travel plan and conditions discussed above before leaving</li> <li>11. Driver's experience level and competency to operate the type of vehicle in the expected conditions and terrain</li> <li>12. Vehicle has proper safety equipment for expected weather conditions (snow chains, flares, triangles, cones, chocks, first aid kits, etc.)</li> <li>13. Performance of a pre-drive inspection of your vehicle</li> <li>14. Performance of a vehicle walk around to ensure all loads are properly secured, the trailer hitch is latched properly, the path of travel is safe, and there are no hazards on, under, above and around the vehicle and path</li> <li>15. Inspection of the inside of the vehicle, ensuring you are familiar with the vehicle and all the accessories (turn on headlights, wipers, jake brake, etc.)</li> <li>16. Adjustments to the seat and mirrors</li> <li>17. Contact made with the receiving site lead to confirm route and ETA</li> <li>18. A passenger has committed to actively passenger assisting the driver in identifying hazards, monitoring safe operations of the vehicle and the driver's alertness/fatigue level</li> <li>19. Commitment to monitoring for fatigue and to stop if you need a break</li> <li>20. Commitment to staying alert and hydrated</li> <li>21. Commitment to stopping if conditions change, evaluating hazards, confirming expected conditions, and stopping if conditions are not as expected and it becomes unsafe to continue your route.</li> </ol> <p>If unable to validate all applicable items above, <b>STOP</b>, and contact your immediate supervisor to discuss how to proceed safely or determine an alternative course of action.</p>
<b>Additional Resources:</b>	<p><a href="https://www.cdc.gov/niosh/motorvehicle/ncmvs/newsletter/ncmvsnewsletterv3n4.html">https://www.cdc.gov/niosh/motorvehicle/ncmvs/newsletter/ncmvsnewsletterv3n4.html</a></p>
<b>Contact:</b>	<p>Jack Suehiro, Director, Enterprise Contractor Safety, PG&amp;E</p> <p>If you have any questions, please do not hesitate to reach out to the Enterprise Contractor Safety team at <a href="mailto:ContractorSafety@pge.com">ContractorSafety@pge.com</a>.</p>



# Safety and Health Tailboard

For leaders to discuss with their team

Safety and Health Tailboards provide topical information and guidance for individuals and teams, often supporting PG&E Standards, Procedures, and Code of Safe Practices.

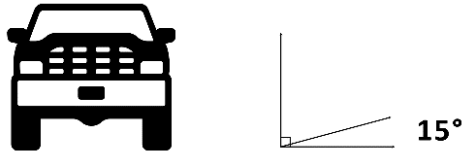
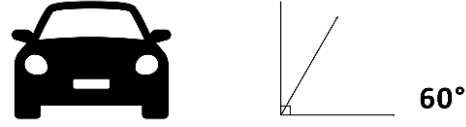
<b>Topic:</b>	Reduce Your Risk of Commercial Vehicle Rollover
<b>Relevant Key to Life:</b>	2. Follow safe driving principles and equipment operating procedures.
<b>Date:</b>	4/1/2023
<b>Start with 6</b>	<ul style="list-style-type: none"> <li>Open the camera feature on your mobile device and focus on the QR code at right.</li> <li>Your camera will automatically take a picture of the code and direct you to Enterprise Contractor Safety's Rollover Campaign.</li> </ul> 
<b>Audience:</b>	All Contract Partners and PG&E Coworkers
<b>Topic Overview:</b>	<p>Each year, commercial vehicle rollovers cause significant loss of life, injuries, and damage to vehicles and property. Truck rollovers are especially common for commercial vehicles and any truck and load with a high center of gravity. The natural instability of high-center-of-gravity trucks can cause a rollover with an incline of as little as 15 degrees. However, vehicles with a slightly lower center of gravity, such as a 4-door sedan, will only roll over if the angle is more than sixty degrees.</p>   <p>Additionally, the conditions under which a vehicle and trailer are loaded before hitting the road can determine the success or failure of the trip. Drivers should carefully inspect the height, weight, and stability before setting out to ensure that any load is secured and within the limits of the truck's capacity and capabilities. If unsure, review the manufacturer's towing guide to check your vehicle and/or trailer's load capacity.</p>
<b>Risks, Exposures &amp; Impacts:</b>	<ol style="list-style-type: none"> <li>Approximately 95% of all rollovers occur from tipping when the vehicle slides sideways across a soft surface (gravel) or hits a guardrail, fence, or tree. The other 5% occur by a high-speed crash avoidance maneuver.</li> <li>According to the National Highway Traffic Safety Administration (NHTSA) and Federal Motor Carrier Safety Administration, approximately 66% of all heavy vehicle rollover crashes occur during the day rather than at night.</li> </ol>

3. Half of the heavy vehicle rollovers involve truck-trailers
4. Due to the size and weight of commercial vehicles, rollover incidents are TWICE as likely to result in fatalities.
5. 78% of all commercial rollover incidents result from driver error.
6. California has the second-highest commercial truck rollover incidents per year.
7. Research shows about 66% of all commercial truck rollovers involve drivers with at least a decade of experience.
8. The four most common causes of commercial vehicle rollovers are driver inexperience or negligence, lack of proper truck maintenance, load imbalance, and bad highway conditions.

### Preventative Steps & Actions to Take

1. Know your vehicle AND how to drive it
  - Understand the design and performance of the truck you will be driving. For example, class 7 and 8 vehicles handle differently than Class 3- 5 pickup trucks.
2. Slow it down, especially reducing speed around curves
  - Even a slight increase in your cornering speed results in a more significant increase in the outward sideways force, which can tip your vehicle.

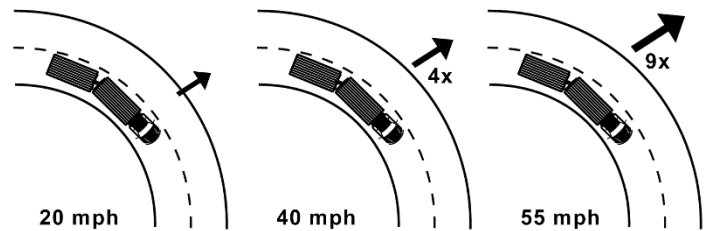

- Soft shoulders can lead to tripping. Tripping occurs when one side of your trailer axle suddenly drops below the other side, resulting in a rollover.
- When unladen (without a trailer), reduce your rate to 5 mph below the recommended speed on the curve warning sign.
- When laden (with a trailer), reduce your speed on curves by 10 mph below the posted speed shown.
- When turning at a roundabout or intersection, stay at low speed until your truck and trailer have fully completed the turn and are straight behind each other on the exit road.
- When turning to get onto on or off-ramps, ensure you have approximately 5 feet of space between the steer axle and the curb to help your trailer avoid climbing the curb and tripping.



	<p>3. Check before you go</p> <ul style="list-style-type: none"> <li>○ Complete a 360 walkaround before operating the vehicle every time. Predictable is preventable. <ul style="list-style-type: none"> <li>▪ Exterior: Examine the road conditions, an exit strategy from the current parking location, potential hazards, objects in blind spots, tire pressure, suspension, etc.</li> <li>▪ Interior: Ensure safety belts are fastened, mirrors are in proper placement, and no warning lights, brakes, etc.</li> </ul> </li> <li>○ Always make sure loads are tied down properly. Shifting loads can easily change your equipment’s center of gravity, leading to a rollover. Learn the proper techniques to secure your load and keep partially loaded compartments to a minimum.</li> </ul>
<b>PPE:</b>	<ul style="list-style-type: none"> <li>• Non-glare sunglasses</li> </ul>
<b>Procedures, Standards &amp; Resources:</b>	<ul style="list-style-type: none"> <li>• <u>CA DMV: Commercial Driver Handbook “Transporting Cargo Safely”</u></li> <li>• Safety Awareness: Off-Road Driving Preparation</li> </ul>
<b>Contact:</b>	Enterprise Contractor Safety Team <a href="mailto:ContractorSafetyInfo@pge.com">ContractorSafetyInfo@pge.com</a>



---

**Subject:** FW: Topock AEG Programmatic HASP 2025 HASP Submittal  
**Attachments:** Topock\_AEG\_Remediation\_Safety-Plan-Checklist\_20241219Rev6.xlsx

---

**From:** ER Safety & Compliance <ERSafetyCompliance@pge.com>  
**Sent:** Monday, March 10, 2025 10:41 AM  
**To:** Newman, Janet <Janet.Newman@arcadis.com>; Glass, John <f2g5@pge.com>; Goddard, Mary-Catherine <Mary-Catherine.Goddard@arcadis.com>; Garrard, Benjamin <B4GY@pge.com>; Diaz, David <D3D6@pge.com>; ER Safety & Compliance <ERSafetyCompliance@pge.com>  
**Cc:** Matt Michaelian <mmichaelian@aegconsultants.com>; Driscoll, Kyle <Kyle.Driscoll@arcadis.com>; Mongan, Zachary <Zachary.Mongan@arcadis.com>; Arcadis Chromium PMO Health and Safety <PGEHealthandSafety@Arcadis.com>  
**Subject:** RE: Topock AEG Programmatic HASP 2025 HASP Submittal

**Arcadis Warning:** Exercise caution with email messages from external sources such as this message. Always verify the sender and avoid clicking on links or scanning QR codes unless certain of their authenticity.

Classification: Internal

Hi Janet and team.

We have completed our review of the Topock AEG HASP/JHA(s) and all comments have been adequately addressed - thank you. We have no further comments. Please find the checklist attached for your records to show close out of all items.

This email acts as an approval signature of the Topock AEG HASP. Please screenshot this email and add to the end of the HASP, if needed.

Next step:

Within one week **and prior to the initiation of work** for new projects/scopes of work **or** prior to the expiration of your existing hasp for ongoing scopes of work, please finalize the document (i.e. remove watermarks, placeholders, etc.), include the **bridging document** as the first series of pages in your final PDF of the safety plan document, **rename** in our standard naming convention (ProjName\_LAC\_Doc-Type\_YearMonthDay\_Final), and **resubmit** to us.

If you have any questions, don't hesitate to reach-out.

Thank you,  
Lauren Baeta  
ER Safety & Compliance Team  
✉ [ERSafetyCompliance@pge.com](mailto:ERSafetyCompliance@pge.com) | [Environmental Remediation](#) | [Pacific Gas and Electric](#)